

August 18, 2021

Ms. Donna Jerry
Health Policy Analyst
Green Mountain Care Board
89 Main Street
Montpelier, VT 05620-3101

Re: Application for Certificate of Need for the Replacement of Existing MRI

Dear Ms. Jerry:

Please find enclosed Rutland Regional Medical Center's (RRMC) Application for a Certificate of Need for the existing 20-year-old magnetic resonance imaging (MRI) scanner. The Application includes the following document:

1. A request for expedited review;
2. The Application for the Certificate of Need; and
3. The Appendix to the Application with information regarding the project details including the architect's narrative description with schematic plans depicting the existing space, and the proposed renovation of the space. The Appendix also includes the requisite financial tables.

As we discussed, this filing does not include a completed Verification Under Oath because one of the primary contributors is out of the office this week. We will submit a completed Verification next week.

Please do not hesitate to contact me at jwallace@rrmc.org or Jonathan Reynolds, Vice President, Clinical Operations via e-mail at jreynolds@rrmc.org or via phone (802-747-1600) should you have any questions. Thank you in advance for your consideration of this request.

Sincerely,

/s/ John H. Wallace

John H. Wallace
General Counsel

Enclosures (3)

August 18, 2021

Ms. Donna Jerry
Health Policy Analyst
Green Mountain Care Board
89 Main Street
Montpelier, VT 05620-3101

Re: Request for Expedited Review for Replacement of Existing MRI

Dear Ms. Jerry:

Rutland Regional Medical Center (RRMC) is seeking an expedited Certificate of Need approval, without a hearing, to replace the current and only magnetic resonance imaging (MRI) scanner, which is over 20 years old and at the end of its useful life. MRI imaging is a core evaluative and diagnostic tool used for clinical care management, and replacement of this equipment is essential to maintain basic medical services within the Rutland region. RRMC's MRI scanner is utilized seven days a week for emergent, inpatient, and outpatient testing services.

The Green Mountain Care Board has jurisdiction over the proposed project because the total project capital costs is approximately \$3,089,595. A detailed explanation of costs is provided as part of the application. Facility renovation costs are included in the project as the replacement will require renovation to the current MRI suite to accommodate the installation of a new magnet. A detailed explanation of costs is provided as part of the application.

Pursuant to 18 V.S.A. § 9440(c)(5)(A), and Rule 4.304, RRMC seeks to obtain expedited review because the project involves a routine replacement of existing medical equipment that involves comparable technology and capability. 18 V.S.A. §9440(c)(5)(D). As required by Rule 4.304, RRMC believes that the application is likely to be uncontested because the project is limited to replacing an existing MRI that will not substantially alter services in that the project will not have a significant impact on (1) on existing services because the change in service will be limited to improvement in image quality and patient experience; (2) the cost of health care; and (3) the RRMC's financial strength because it will be financed by working capital.

In accordance with 18 V.S.A. § 9440(c)(2) and Rule 4, we are providing the following information about the project as further described in the enclosed application:

Project Scope and Expenditures: The application requests a CON approving (1) purchase of a new GE Healthcare SIGNA Artist 1.5T 96 Channel 29.1 MRI scanner for a capital equipment cost of \$1,899,230.43; and (2) renovation of existing MRI space located in the existing MRI department

space at the main hospital with construction costs of \$1,190,365 for a total capital expense of approximately \$3,089,595. The detailed explanation of costs is included in the application narrative and the Appendix at pages 188-189.

Project Rationale: RRMC needs to replace its sole MRI scanner, which is twenty years old and is subject to frequent downtimes.

Need to be Addressed: As the only MRI scanner in the Rutland Hospital Service Area, the project will ensure the continued access to existing services.

Cost, Access, Quality: The project will maintain existing access while improving the patient experience and enhancing diagnostic image quality.

Location: Rutland Regional Medical Center, 160 Allen Street, Rutland, Vermont.

Service Area: RRMC is the only provider of MRI services in the Rutland Hospital Service Area.

Please do not hesitate to contact me or Jonathan Reynolds, Vice President, Clinical Operations via e-mail at jreynolds@rrmc.org or via phone (802-747-1600) should you have further questions. Thank you in advance for your consideration of this request.

Sincerely,

/s/ Claudio D. Fort

Claudio D. Fort

President & Chief Executive Officer

Enclosures (2)

**STATE OF VERMONT
GREEN MOUNTAIN CARE BOARD**

**CERTIFICATE OF NEED APPLICATION
RUTLAND REGIONAL MEDICAL CENTER**

**RE:
Replacement of Existing MRI**

August 18, 2021

Table of Contents

Page

Project Summary	3
CON Standard 1.1, 1.4	4
CON Standard 1.6	5
CON Standard 1.7, 1.8, 1.9.....	6
CON Standard 1.10, 1.11, 1.12, 3.4	8
CON Standard 3.5	9
CON Standard 3.7	10
CON Standard 3.19, 3.20	11
CON Standard 3.22, 3.23	12
CON Standard 3.24	13
CON Standard 1, 2	13
CON Standard 3, 4, 5, 6	14
CON Standard 7, 8, 9	15

I: PROJECT SUMMARY

Rutland Regional Medical Center (RRMC) operates an American College of Radiology (ACR) accredited MRI department. RRMC operates a single magnetic resonance imaging (MRI) machine. The MRI machine operates weekdays from 7:00 AM to 11:00 PM, and weekends and holidays from 9:00 AM to 5:30 PM.

RRMC is seeking a CON to replace its existing twenty-year-old GE 1.5T HDX Echospeed 8 Channel MRI Signa LX scanner (Appendix 7.a, p.94). Because of the age of the equipment, GE has discontinued equipment upgrades. In addition, the operation of the equipment is subject to an increasing frequency and duration of downtimes, including delays associated with replacement part scarcity (Appendix 7.b, p.95). The MRI experienced 126 downtimes over the twelve-month period from June 2020 through June 2021, which involved instances where the system was not available to scan. The downtimes resulted in the system being unavailable for an average of ten hours and thirty minutes per month.

The replacement MRI machine is a GE Healthcare SIGNA Artist 1.5T 96 Channel 29.1 MR System. The net capital equipment cost for the replacement MRI will be \$1,899,230.43 (Appendix 8.a, p.188). The replacement MRI was selected for its superior image quality and technology features that will improve patient comfort. The equipment will not result in increased volume or include new or different services. The equipment replacement will not result in changes in operating hours, staffing, or charges. The equipment purchases also include accessory items of new MRI magnet safe infusion pumps and patient vitals monitors (Appendix 1.d & 1.e, p-36-39).

As required by Rule 4.304.3(a), the costs associated with the project include the following:

1. Capital expense for the project is approximately \$3,089,595

Construction costs	
Renovation	\$731,186
Site work	\$2,800
Construction contingency	\$72,741
Construction manager fee	\$41,691
<i>Construction costs subtotal</i>	\$848,418
Project costs	
Equipment	\$1,899,230
Furnishings, fixtures and other	\$84,842
Architectural/Engineering fee	\$172,263
Working capital	\$84,842
<i>Project costs subtotal</i>	\$2,241,177
Total Project Capital Costs	\$3,089,595
Total Project Operating Costs	\$199,276

The construction costs associated with the project are also detailed in (Appendix 8.a, p.188). The replacement MRI will be located in the current MRI space in the main hospital building at 160 Allen Street. To minimize the cost of the project, construction will be limited to renovation of existing space to accommodate a larger equipment footprint and to comply with updated MRI safety guidelines regarding space configuration. The construction will include upgrading the interior vault and equipment room to accommodate the new MRI and support equipment. The project will also include renovation of approximately 160 square feet to create new ADA compliant patient changing booths and patient interview area. The anticipated project timeline for completion is nineteen weeks, which includes one week for removal of exiting MRI, two weeks for renovation, two weeks for installation of new magnet and post installation renovation, and one week for training. During the project, RRMC will use a mobile MRI unit adjacent to the building outside the Diagnostic Imaging Department. Patients will be transported under an awning to the mobile unit. The mobile MRI will provide the same quality and capacity as the existing MRI. The details and costs for the mobile unit are included in Appendix 4.b, p.79.

CON STANDARD 1.1: Applicants shall include published GMCB quality measures for services related to a specific application, for the applicant and other hospitals that report on that quality measure. The applicant shall demonstrate how the project will improve or assist in the improvement of the relevant quality measures, if the applicant's score is not above the national or the Vermont average.

The GMCB does not publish quality measures for MRI. As part of the Medicare.gov Hospital Compare program, the U.S. Department of Health and Human Services (HHS) reports data regarding the utilization of MRI for the percentage of outpatients with low-back pain who had an MRI without trying recommended treatments (like physical therapy) first. The percentage for RRMC is 36.8% compared to a national average of 39% and a Vermont average of 28.9%. HHS does not report data on this measure for most Vermont hospitals because the volume is too low to report. The only other independent hospital reported in Vermont is Northwestern Medical Center at 35.1%. The other reported hospitals are Central Vermont Medical Center at 32.8%, and the University of Vermont Medical Center at 21.4%. It is anticipated that the recent implementation of the Medicare Appropriate Use Criteria for Advanced Diagnostic Imaging, which requires ordering practitioners to consult a decision support tool with appropriate use criteria for all tests ordered for Medicare beneficiaries, should contribute to improving this utilization metric as it influences independent practitioners ordering.

CON STANDARD 1.4: If an application proposes services for which a higher volume of such service is positively correlated to better quality, the applicant shall show that it will be able to maintain appropriate volume for the service and that the addition of the service at the facility will not erode volume at any other Vermont facility in such a way that quality at that facility could be compromised.

The replacement MRI will provide the same level of service that we currently offer with no new volume planned. MRI testing is a core imaging modality used by primary care practitioners throughout the Rutland Hospital Service Area (HSA) and physician and practitioner specialists including emergency medicine, oncology, orthopaedics, and hospital medicine. The new equipment will continue to offer existing services for hospital patients. RRMC provides MRI

imaging that is standard testing for a community hospital environment. MRI imaging is essential for cancer diagnosis and follow up, orthopedic evaluation, triaging emergency department patients for stroke evaluation, and neurology. The graphs below depict MRI utilization over the past four years.

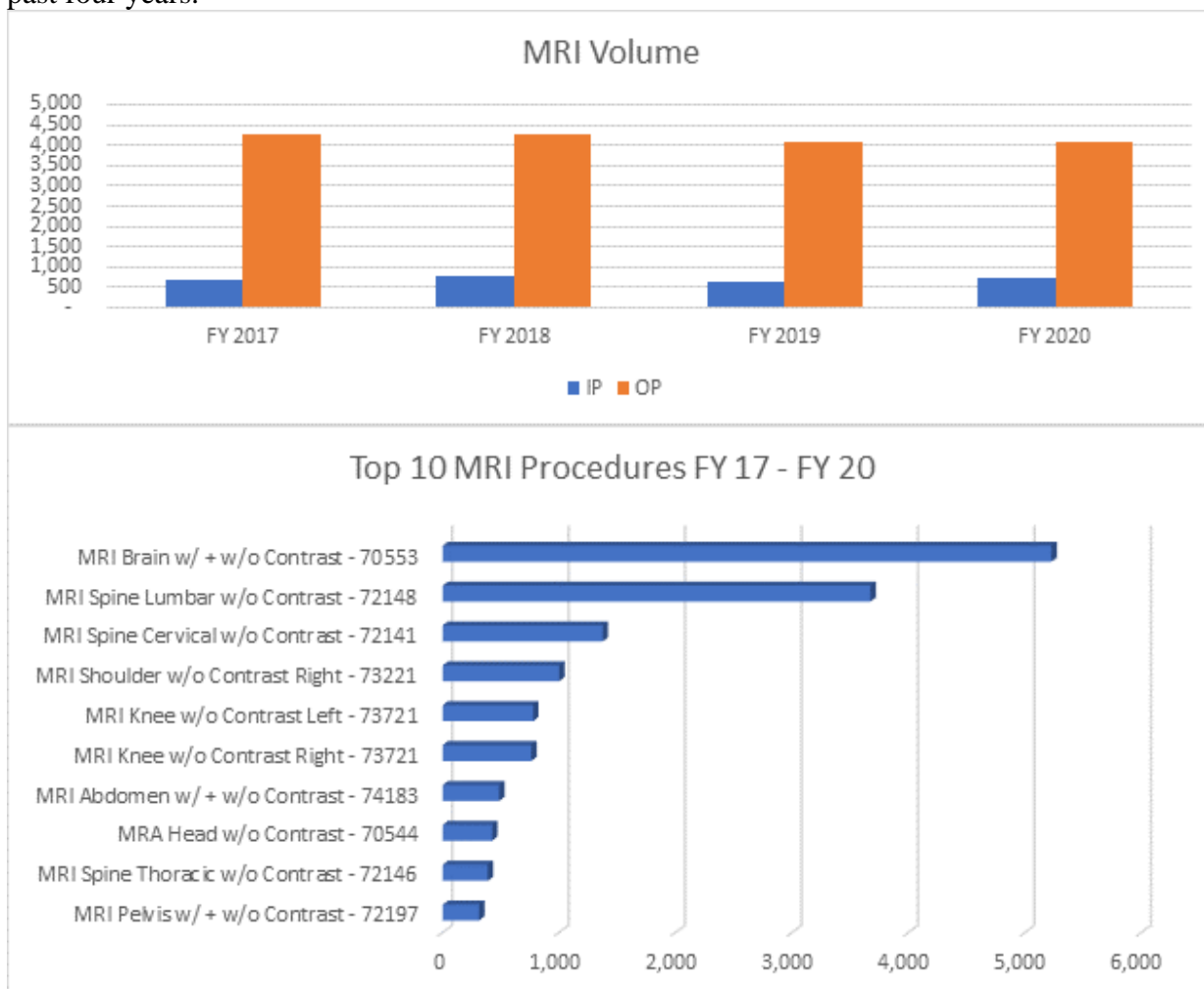

CON STANDARD 1.6: Applicants seeking to develop a new health care project shall explain how the applicant will collect and monitor data relating to health care quality and outcomes related to the proposed new health care project. To the extent practicable, such data collection and monitoring shall be aligned with related data collection and monitoring efforts, whether within the applicant's organization, other organizations or the government.

Monitoring and optimizing image quality is a prominent focus of RRMC’s MRI process. Each imaging modality has an assigned radiologist or Chief who is responsible for overseeing the modality’s quality and outcomes. The MRI Chief and MRI Lead Technologist evaluate MRI image quality on an ongoing basis to identify opportunities for improvement for either MRI staff or software or hardware performance. The MRI Lead Tech is responsible for providing feedback and training to MRI technologists when necessary to improve image quality.

Another indicator of quality is the MRI cancellation rate. A typical cause of MRI cancellations is an inadequate prescreening patient evaluation to identify if a patient is claustrophobic or has a

limited tolerance for small spaces. For patients with an identified concern with small spaces, the Diagnostic Imaging nursing service provides medical support to ensure patient comfort and minimize cancellation and the associated delay in care. In the event that an exam cancelled due to a patient's discomfort, the MRI technologist contacts the ordering practitioner to coordinate a plan to reschedule, which may include the use of supportive medication.

CON STANDARD 1.7: Applicants seeking to develop a new health care project shall explain how such project is consistent with evidence-based practice. Such explanation may include a description of how practitioners will be made aware of evidence-based practice guidelines and how such guidelines will be incorporated into ongoing decision making. (2005 State Health Plan, page 48.)

Practitioners who order MRIs for Medicare beneficiaries are required to use a decision support tool that includes evidence-based MRI utilization criteria. The use of evidence-based utilization criteria is required by the Protecting Access to Medicare Act (PAMA) at section 1834(q) of the Social Security Act codified at 42 U.S.C. § 1395m and associated regulations at 42 CFR § 419.94. In addition, the MRI Lead Technologist uses evidence-based criteria from the American College of Radiology (ACR) Appropriateness Criteria to reviews MRI orders in advance of performing the test to ensure that the test is appropriate for the diagnosis or reason for the test. In the event that an order for a test is inconsistent with the ACR Appropriateness Criteria, the Lead Technologist and American Registry of Radiologic Technologists (ARRT) certified technologists review the ordered test obtain all other relevant clinical information from the ordering practitioner that supports the test and discuss the appropriateness of the test with a radiologist.

CON STANDARD 1.8: Applicants seeking to develop a new health care project shall demonstrate, as appropriate, that the applicant has a comprehensive evidence-based system for controlling infectious disease.

The infection prevention practices associated with the Diagnostic Imaging Department and the MRI service are integrated into the RPMC Infection Prevention Program (IP). The IP Program is designed to ensure compliance with The Joint Commission Hospital Accreditation Standard to prevent, control, and investigate infections and communicable diseases. The Program is based on numerous sources of evidence including The Center for Disease Control and Prevention, The Centers for Medicare and Medicaid, Conditions of Participation for Hospitals, and the Association for Professional Infection Prevention and Epidemiology. The IP Program was most recently reviewed by Vermont Division of Licensing & Protection (L&P) on December 15, 2020. The L&P surveyors conducted a focused infection control survey. The surveyors made no regulatory findings and found that the facility was in substantial compliance with the infection control regulatory requirements.

The IP Program is integrated into individual departments throughout the Hospital including Diagnostic Imaging. The Infection Preventionists provide surveillance, feedback, and training throughout the Hospital. The Environmental Services Lead Technician provides training regarding the cleaning procedure to all Diagnostic Imaging and Environmental Services staff who work in DI.

CON Standard 1.9: Applicants proposing construction projects shall show that the costs and methods of the proposed construction are necessary and reasonable. Applicants shall show that the project is cost-effective and that reasonable energy conservation measures have been taken.

In relation to the selection of the replacement MRI, the DI Department assigned a selection team that included the radiologists and the MRI Lead Technologist to identify a cost effective replacement for the current MRI. The selection team evaluated the two top manufacturers based on diagnostic image quality Philips and GE. The selection team visited the Philips' site to evaluate that system. The team decided to continue using a GE system due to superior image quality and the enhanced patient friendly coil technology, and better service availability. The new coil technology has a higher number of receivers within them to provide improved image quality. The new coils are also made of a pliable material so that they rest close to the body part that is being imaged. The pliable coils are more comfortable and less restrictive than the current technology, which will contribute to an improved patient experience.

To ensure that we were receiving a competitive price from GE, an MD Buyline Analysis was completed, and our quote was consistent with the MD Buyline recommended price.

To minimize the cost of the project there is no new construction, expansion or modification to the exterior envelop of the building. However, the project involves an expansive renovation of the existing space to allow for the new equipment's larger footprint and the associated space requirements. The existing MRI space was constructed twenty years ago. Since that time, the American College of Radiology (ACR) has made numerous changes to its safety recommendations. The existing MRI space is not large enough to comply with the ACR Manual on MR Safety recommendations regarding discrete safety zones around the MR system.¹ The project will involve expanding the existing space to allow for the addition of a new Safety Zone II.

The existing MRI suite is 1,070 gross square feet consisting of a 475 square foot imaging vault (Safety Zone IV), a 156 square foot Control Room and 151 Patient Holding area (Safety Zone III), and a 165 square foot equipment room. Patients enter from a public corridor (Safety Zone I) directly into the Patient Holding area (Safety Zone III) with access control and ferromagnetic detection at the corridor door. The current MRI space does not include a distinct Safety Zone II. The purpose of Safety Zone II is to create separation between publicly accessible space and strictly controlled Zones III and IV. The renovation will include converting an existing office into the new Zone II. (Appendix 3.c p. 75) The new Zone II will serve as space for a waiting room, dressing room, and an area for review of completed safety and screening forms. (Appendix 3.c p. 77). A narrative description of the space renovation is included in a letter from Lavallee/Brensinger Architects (Appendix 3.c, p.72-76). An engineering narrative description of

¹ ACR Committee on MR Safety, ACR Manual on MR Safety\ Version 1.0 2020.

the mechanical and electrical work is included in a letter from LN Consulting. (Appendix 3.b, p.70-71).

The renovations will include interior vault upgrades to accommodate the new MRI, modifications to the equipment room to support the MRI equipment, cosmetic renovations to the Control Room and Patient Holding area, and renovation of approximately 160 square feet to create new Safety Zone II with ADA compliant patient changing booths and an interview area with access directly off the public corridor (Safety Zone I). The cost for the proposed construction is \$701.17 per sf, which is very competitive for this type of work. To ensure that actual construction costs are competitive and cost effective, RRMC will obtain multiple competitive bids from all trades providing services listed in the Budget Estimate such as masonry, carpentry, plumbing, heating, ventilation, air conditioning, and electrical (Appendix 3.a, p.62-69).

RRMC collaborates with Efficiency Vermont on all projects to ensure that the projects are cost effective and efficient. Efficiency Vermont is involved in this project as well and a letter from Efficiency Vermont is attached following this narrative. (Appendix 3.d, p.77)

CON STANDARD 1.10: Applicants proposing new health care projects requiring construction shall show such projects are energy efficient. As appropriate, applicants shall show that Efficiency Vermont, or an organization with similar expertise, has been consulted on the proposal.

RRMC collaborates with Efficiency VT on all projects, and Efficiency VT has been involved in this project as well. A letter from Efficiency Vermont is attached following this narrative. In addition, the Architects and Engineers on the project have strong backgrounds in energy efficiency and have worked extensively with Efficiency Vermont. (Appendix 3.d, p.77)

CON STANDARD 1.11: Applicants proposing new health care projects requiring new construction shall demonstrate that the new construction is the more appropriate alternative when compared to renovation.

There is no new construction proposed in this project. All construction costs are associated with modification of existing space.

CON STANADARD 1.12: New Construction of health care projects shall comply with the Guidelines for Construction and Equipment of Hospital and Medical Facilities as issued by the American Institute of Architects (AIA).

There is no new construction proposed in this project. The project's architecture firm, Lavallee/Brensinger has been involved in numerous CON related projects. The Appendix includes a letter from Lavallee/Brensinger, which states that all renovations will comply with the 2018 edition of the Guidelines for Design and Construction of Hospitals, FGI section 2.2-3.4.5 for Magnetic Resonance Imaging Facilities. RRMC will not seek a waiver of any FGI guidelines. *See Lavallee/Brensinger Architects letter dated June 29, 2021 (Appendix 3.c, p.72-76).*

CON STANDARD 3.4: Applicants subject to budget review shall demonstrate that a proposed project has been included in hospital budget submissions or explain why inclusion was not feasible.

The MRI project has been included in our planning process since 2018. Budget considerations in 2018 and 2019 only supported plans to upgrade the existing MRI machine. In 2020, at the advice and of our radiologists, we reconsidered the plan and decided to replace the entire magnet along with the new hardware and software. Utilizing our old magnet would have been prohibitive to any future technological advances that would provide improved image quality that are clinical industry standards. The project was included in capital plans as follows:

Budget 2018 – MRI Full Upgrade \$879,589, Included in FY 2019 on 4 Year Capital Plan

Budget 2019 – MRI Full Upgrade \$799,627, Included in FY 2020 in 4 Year Capital Plan

Budget 2020 – MRI Replacement \$3,059,885, Included for FY 2020 (delayed due to COVID)

Budget 2021 – MRI Replacement \$3,218,967, CON, included for FY 2021

CON STANDARD 3.5: Magnetic resonance imaging (MRI) capacity shall not be increased until current capacity is in excess of valid state, regional and/or national benchmarks for medically necessary exams per year and sufficient additional need is demonstrated based on such benchmarks. An applicant proposing a project involving MRI shall provide information on current use, document the effectiveness of the internal program utilized by the applicant to prevent overuse, and verify that the applicant does not have financial incentives in place to encourage MRI utilization.

The replacement MRI will not increase capacity or volume. The replacement MRI will allow the studies to be completed in a shorter period of time, which will allow patients to be more comfortable and compliant.

a. MRI utilization management

The RRMC utilization management process ensure that MRI utilization is appropriate. Practitioners who order MRIs for Medicare beneficiaries are required to use a decision support tool that includes evidence-based MRI utilization criteria. The use of evidence-based utilization criteria is required by the Protecting Access to Medicare Act (PAMA) at section 1834(q) of the Social Security Act codified at 42 U.S.C. § 1395m and associated regulations at 42 CFR § 419.94. In addition, the MRI Lead Technologist uses evidence-based criteria from the American College of Radiology (ACR) Appropriateness Criteria to review MRI orders in advance of performing the test to ensure that the test is appropriate for the diagnosis or reason for the test. In the event that an order for a test is inconsistent with the ACR Appropriateness Criteria, the Lead Technologist and American Registry of Radiologic Technologists (ARRT) certified technologists review the ordered test, obtain all other relevant clinical information from the ordering practitioner that supports the test, and discuss the appropriateness of the test with a radiologist. The reviewing technologist also reviews exams to avoid potentially duplicative testing.

In addition, the Diagnostic Imaging Department reviews all scheduled outpatient exams in advance of the test to ensure that the test will satisfy medical necessity coverage guidelines for the patient's health plan and/or the Prior Auth staff verify with the patient's health plan that the test is prior authorized.

b. Financial incentives

RRMC does not use any financial incentives to affect MRI utilization.

Based on calendar year 2019 Vermont Association of Hospitals and Health Systems data, MRI utilization of Rutland County Residents is approximately 51.7 scans/1,000 residents. It is important to note that utilization data of the counties situated along the New Hampshire border (Essex, Caledonia, Orange, and Windsor) are skewed as MRI utilization at Dartmouth Hitchcock Medical Center are not included in this data set. Based on these counties data limitations, we have excluded them in our comparison. Considering the other counties in the State, our utilization compares to the low end of Windom County being 43.9 scans/1,000 and the high end of Franklin County being 62.1 scans per 1,000. Rutland utilization is the State midpoint for the nine counties included in the comparison.

We have also included 2020 utilization metrics which have similar comparative results, but lessor utilization due to the impact of COVID.

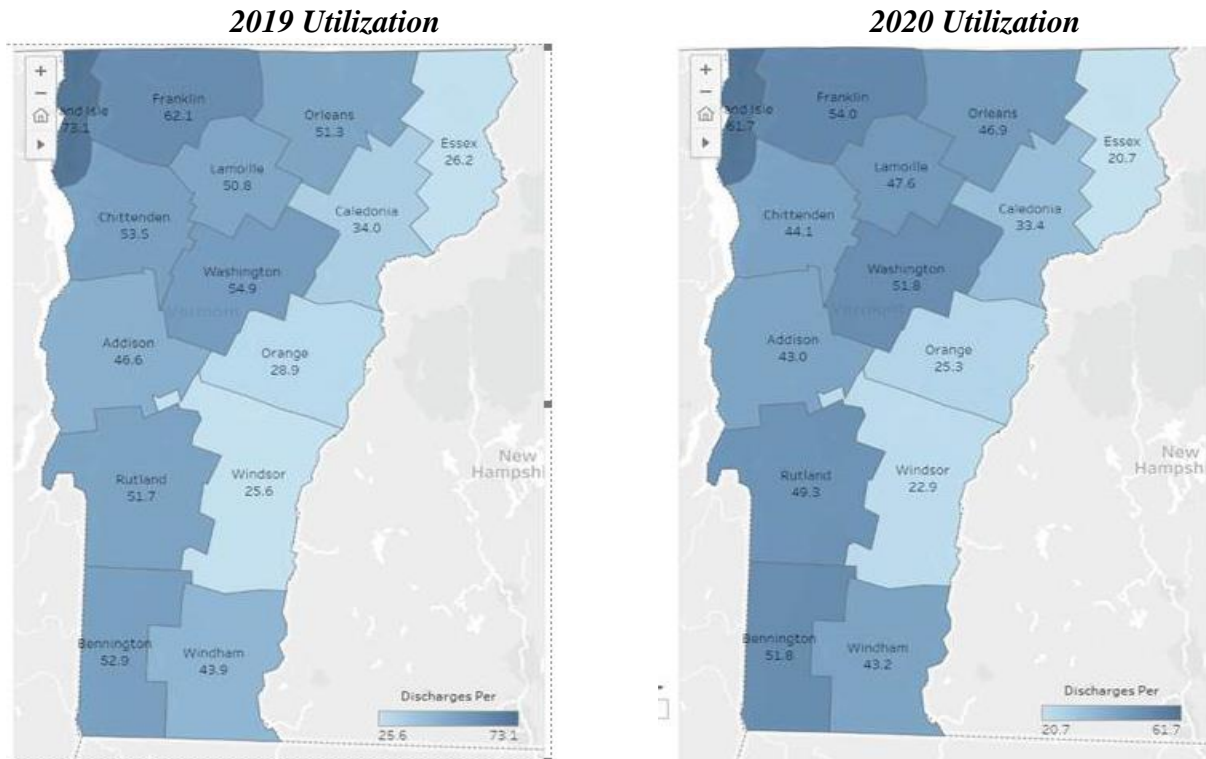

Inpatient & Outpatient Discharge data sourced from 14 Vermont hospitals and Brattleboro Retreat as collected, combined, and prepared by VAHHS-NSO

CON STANDARD 3.7: Applicants proposing to replace diagnostic or therapeutic equipment shall demonstrate that existing equipment is fully depreciated, or the cost of the early replacement, including the cost of the remaining depreciation on existing equipment, is less costly than keeping the existing equipment.

The existing MRI total project costs were \$2,690,072, including \$1,989,571 for the original purchase and \$700,501 for hardware and software upgrades. The MRI was placed in service in 2001, which was followed by a series of upgrades from 2007 to 2012. A schedule of upgrades is listed below:

The MRI had a useful life that ranged from 3 to 10 years depending on the component of the equipment. As of 2019, the equipment and all upgrades were fully depreciated. The costs are outlined below:

FY	Description	Original Amount	Useful Life
2007	INSTALL SOFTWARE FOR INVIVIO MRI DYNACAD WORKSTATION	\$ 2,000	3
2007	INVIVIO MRI DYNACAD WORKSTATION	\$ 55,040	5
2007	GE MRI PROPELLER HD SOFTWARE UPGRADE	\$ 42,448	3
2007	GE 1.5 8 CHANNEL FOOT & ANKLE COIL FOR MRI	\$ 30,690	5
2008	GE EXCITE 1.5T EIGHT WRIST COIL ARRAY	\$ 24,650	5
2009	MRIDIUM SIDE CAR B CHANNEL FOR MRI COMPATIBLE INFUSION PUMP	\$ 6,003	10
2009	MRIDIUM INFUSION PUMP	\$ 12,504	10
2009	REFURBISHED MRI TABLE	\$ 8,900	5
2012	SOFTWARE UPGRADE FOR MRI VIBRANT GE SIGNA HD	\$ 33,352	3
2012	MRI HARDWARE SIGNA HDXT UPGRADE (80% UPON DELIVERY)	\$ 315,723	5
2012	SOFTWARE - DYNACAD ENTERPRISE LICENSES, W/ PROSTATE & QUICKCLOCK SEGMENT	\$ 62,659	3
2012	DYNATRIM TRANSRECTAL INTERVENTIONAL MR DEVICE W/ STARTER KIT	\$ 27,601	5
2012	MRI HARDWARE SIGNA HDXT UPGRADE (20% UPON INSTALL)	\$ 78,931	5
	Total Cost of Upgrades	\$ 700,501	
2001	MRI SYSTEM (PARTIAL PAYMENT)	\$ 33,020	5
2001	MRI SYSTEM (PARTIAL PAYMENT)	\$ 8,255	5
2001	MRI SIGNA HORIZON LX SYSTEM	\$ 779,319	5
2001	MRI SIGNA HORIZON LX SYSTEM	\$ 779,319	5
2001	MRI SIGNA HORIZON LX SYSTEM	\$ 389,659	5
	Total Cost of Original MRI	\$ 1,989,571	

RRMC will trade-in the existing MRI to GE Healthcare as part of the purchase. GE Healthcare has agreed to give us a credit of \$60,000 against the new Artist 1.5 Tesla MRI. We have received comparable fair market value estimates from eBay and Grand Medical Equipment. The equipment valuations from both reselling companies supports the value that GE has agreed to. (Appendix 2.a & 2b, p. 40-61)

CON STANDARD 3.19: An applicant seeking to purchase a piece of diagnostic or therapeutic equipment shall include an analysis of whether other health care system costs may be reduced through more effective interventions through the use of the equipment. As appropriate, hospitals shall provide scientific evidence supporting the migration of such equipment and technology outside of tertiary care facilities.

As a geographically isolated community hospital that serves of a community of approximately 60,000 individuals who reside in an area of roughly 1,000 square miles, RRMC needs an MRI that has the capacity to assist with high quality care to meet the region’s basic health care needs. The MRI provides critical services that reduce costs and support improved outcomes, such as use for a stroke protocol to determine if a patient can be managed locally or needs to be transferred to a tertiary care center. The MRI is also used in the early detection of illness and for evaluating ongoing cancer treatment. The MRI is also a critical tool for RRMC’s Orthopaedic program to allow practitioners to see soft tissue injuries to guide precise treatment.

CON STANDARD 3.20: Applications to purchase diagnostic or therapeutic equipment, or to expand facilities to accommodate major medical equipment purchases, shall address the appropriateness of such distribution as compared to population, the availability of appropriately trained personnel, an evaluation of patient need versus convenience, urgent versus non-urgent use, and appropriate protocol to reduce the risk of repetitive testing(both within the facility purchasing the equipment and within the health care system).

If RRMC is unable to replace its existing MRI, patients would need to travel an hour or more. The replacement MRI would be staffed by existing personnel, which includes six licensed MRI technologists.

As discussed in response to CON Standard 3.5, RRMC has processes to ensure the appropriate use of MRI. The Radiology Information System identify potential repetitive testing to allow for appropriate cancellation or modification of duplicative testing.

CON STANDARD 3.22: For applications involving the purchase of diagnostic or therapeutic equipment, applicants shall establish, through the submission of evidence in the form of peer-reviewed or similar articles, the clinical efficacy of the diagnoses or procedures to be performed.

An MRI scanner can be used to take images of any part of the body (e.g., head, joints, abdomen, legs, etc.), in any imaging direction. MRI provides better soft tissue contrast than CT and can differentiate better between fat, water, muscle, and other soft tissue than CT. These images provide information to physicians and can be useful in diagnosing a wide variety of diseases and conditions. U.S. Food & Drug Administration, MRI, Benefits and Risks (Dec. 9, 2017) <https://www.fda.gov/radiation-emitting-products/mri-magnetic-resonance-imaging/benefits-and-risks>

MRI scanners are particularly well suited to image the non-bony parts or soft tissues of the body. They differ from computed tomography (CT), in that they do not use the damaging ionizing radiation of x-rays. The brain, spinal cord and nerves, as well as muscles, ligaments, and tendons are seen much more clearly with MRI than with regular x-rays and CT; for this reason, MRI is often used to image knee and shoulder injuries. In the brain, MRI can differentiate between white matter and grey matter and can also be used to diagnose aneurysms and tumors. Because MRI does not use x-rays or other radiation, it is the imaging modality of choice when frequent imaging is required for diagnosis or therapy, especially in the brain. U.S. Department of Health & Human Services, National Institute of Biomedical Imaging and Bioengineering, Magnetic Resonance Imaging, <https://www.nibib.nih.gov/science-education/science-topics/magnetic-resonance-imaging-mri>

CON STANDARD 3.23: In addition to proving need, applicants seeking to add or expand diagnostic or therapeutic equipment shall show that the equipment reduces costs and/or improves quality.

RRMC's need to replace the MRI scanner relates to maintaining our quality of Care. RRMC's MRI scanner is utilized seven days a week for emergent, inpatient, and outpatient testing services. Parts are likely to become unobtainable and the machine is at end of life. The total

MRI downtime where the system was not available to scan for the last 12 months from June 2020 through June 2021 was 126 hours with an average downtime per month of 10.5 hours (Appendix 7.h, p.181).

While the new MRI machine will have no new functionality over the current one, it will come with improvements to software and hardware that will provide a better image quality that diagnostically may lead to better patient outcomes. Additionally, many patients of a larger girth must seek their MRI scans elsewhere (often out of state to Dartmouth Hitchcock). The replacement MRI will have a wider 70 centimeter bore that will accommodate larger patients and those that have difficulty in confined spaces. With a larger bore size, these individuals will not be forced to travel for an MRI and the new machine will be more appropriate for the population. The increased access for larger patients will not lead to a material change in volume, but will lessen the number of patients who need to travel outside of the region for an MRI.

CON STANDARD 3.24: An applicant shall disclose potential financial conflicts of interest between hospitals and physicians and an equipment purchase.

There are no known or perceived conflicts of interest with regard to the purchase of this replacement equipment between RRMC, physicians, and the equipment purchase.

CONSISTENCY WITH 18 V.S.A. § 9437

The proposed Project meets the statutory criteria set forth in Section 9437 of the Vermont Certificate of Need law.

§9437 Criteria

1. Proposed project aligns with statewide health care reform goals and principles because the project: A. takes into consideration the health care payment and delivery system reform initiatives.

The replacement MRI may result in cost savings because of higher quality images that could lead to improved continuity of care and outcomes associated with early detection and more precise treatment. In addition, the failure to replace the MRI would result in reduced access to imaging service as the performance and reliability of the existing MRI deteriorates.

B. addresses current and future community needs in a manner that balances statewide needs, if applicable; and

The replacement MRI will be sufficient to address the future community needs.

C. is consistent with appropriate allocation of health care resources, including appropriate utilization of services, as identified in the Health Resource Allocation Plan developed pursuant to section 9405 of this title.

RRMC is the sole provider for MRI service within the Rutland Hospital Service Area. MRI is a core diagnostic modality, which is necessary to manage the health of the region.

2. The cost of project is reasonable, because each of the following conditions is met:

A. The applicant's financial condition will sustain any financial burden likely to result from completion of the project;

The capital expenditure will represent 22.5 percent of the FY 2022 capital budget. The project will be funded with working capital and not impose a significant financial burden. The project will not result in increased operational costs.

B. The project will not result in an undue increase in the costs of medical care or an undue impact on the affordability of medical care for consumers. In making a finding, the Board shall consider and weigh relevant factors, including:

- (i) The financial implications of the project on hospitals and other clinical settings, including the impact on their services, expenditures, and charges; and**
- (ii) Whether the impact on services, expenditures, and charges is outweighed by the benefit of the project to the public.**

The project involves replacement of existing equipment and will not result in an undue increase in costs or affordability. The project will not affect charges.

C. Less expensive alternatives do not exist, would be unsatisfactory, or are not feasible or appropriate.

The selection team of radiologists and MRI Lead Technologist researched the Phillips MRI product and the GE product. The team recommending the continued use of the GE system due to its superior image quality and enhanced patient friendly coil technology. An MD Buyline analysis was completed to ensure GE provides a competitive price, which confirmed that GE's price quote was consistent with the MD Buyline recommended price.

To minimize the cost of the project, there is no new construction, expansion or modification to the exterior envelop of the building. There are no known alternatives.

D. If applicable, the applicant has incorporated appropriate energy efficiency measures.

RRMC collaborates with Efficiency VT on all projects, and Efficiency VT has been involved in this project as well. A letter from Efficiency Vermont is attached following this narrative. In addition, the Architects and Engineers on the project have strong backgrounds in energy efficiency and have worked extensively with Efficiency Vermont.

3. There is an identifiable, existing, or reasonably anticipated need for the proposed project that is appropriate for the applicant to provide.

The existing MRI is twenty years old. RRMC needs to replace the existing MRI to ensure the continuation of the service.

4. The project will improve the quality of health care in the State or provide greater access to health care for Vermont's residents, or both.

The replacement MRI will result in improved MRI image quality and patient experience. The project will not affect access.

5. The project will not have an undue adverse impact on any other existing services provided by the applicant.

The replacement MRI will not adversely impact any other services.

6. REPEALED

7. The applicant has adequately considered the availability of affordable, accessible transportation services to the facility, if applicable.

The MRI will be located in the main hospital building, which is accessible to car, local bus service, Medicaid Non-Emergency Medical Transportation, and the RRMC operated volunteer transportation program Bridges and Beyond.

8. If the application is for the purchase or lease of new Health Care Information Technology, it conforms with the Health Information Technology Plan established under section 9351 of this title.

The Project does not involve the purchase or lease of new Health Care Information Technology.

9. The project will support equal access to appropriate mental health care that meets standards of quality, access, and affordability equivalent to other components of health care as part of an integrated, holistic system of care, as appropriate.

The Project has no relationship to mental health care access.

Rutland Regional Medical Center

MRI Replacement – Certificate of Need Appendix

1.	EQUIPMENT.....	2-39
	a. GE Signa Artist 1.5T MRI Machine and Accessories	2-25
	b. GE Rigging Services	26-30
	c. GE Closed Circuit TV & Camera Patient Monitoring System	31-35
	d. Philips Expression MR400 (MRI-Safe Patient Vitals Monitor)	36-38
	e. Iradimed 3860+ Pump (Non-Magnetic Infusion Pump).....	39
2.	EQUIPMENT TRADE IN VALUE.....	40-61
	a. Trade in of Current MRI Machine.....	40-54
	b. Trade in Comparables	55-61
3.	FACILITY	62-77
	a. Construction Quotes (HP Cummings).....	62-69
	b. Engineering Letter (LN Consulting)	70-71
	c. Architectural Letter and Plans (Lavallee Brensinger)	72-76
	d. Efficiency VT Letter	77
4.	PURCHASED SERVICES	78-82
	a. Physicist Survey of new MRI (Cardinal Medical Physics)	78
	b. Temporary Mobile MRI Rental (Alliance Healthcare Radiology)	79-82
5.	TRAINING	81, 83-88
	a. GE Training Costs	83-88
	b. Mobile Unit Training Costs	(on quote) 81
6.	SERVICE CONTRACTS.....	39, 89-93
	a. GE	89-91
	b. Philips.....	92-93
	c. Iradimed	(on quote) 39
7.	MISCELLANEOUS	94-187
	a. GE MRI End of Service Notification	94
	b. GE Email speaking to difficulty sourcing parts	95
	c. GE MRI Surface Coils End of Service Notification	96
	d. Iradimed End of Service Notification	97-98
	e. Bayer MR Injection System End of Service Notification	99
	f. GE Signa Artist Technical Specifications	100-156
	g. GE Signa Artist Final Study Drawings	157-180
	h. MRI Downtime Report: past 12 months	181- 187
8.	FINANCIAL TABLES	188-189
	a. Table 1: Project Costs	188
	b. Table 2: Debt Financing & Sources of Funds	189



Rutland Regional Medical Center
 160 Allen St
 Rutland, VT 05701-4560

This Agreement (as defined below) is by and between the Customer and the GE Healthcare business (“GE Healthcare”), each as identified below for the sale and purchase of the Products and/or Services identified in this Quotation, together with any applicable schedules referred to herein (“Quotation”). “Agreement” is this Quotation and either: (i) the Governing Agreement identified below; or (ii) if no Governing Agreement is identified, the GE Healthcare Terms and Conditions and Warranties that apply to the Products and/or Services identified in this Quotation. In the event of conflict, the Quotation supersedes.

GE Healthcare can withdraw this Quotation at any time before Customer: (i) signs and returns this Quotation or (ii) provides evidence of Quotation acceptance satisfactory to GE Healthcare (“Quotation Acceptance”). On Quotation Acceptance, this Agreement is the complete and final agreement of the parties relating to the Products and/or Services identified in this Quotation. There is no reliance on any terms other than those expressly stated or incorporated by reference in this Agreement and, except as permitted in this Agreement, no attempt to modify will be binding unless agreed to in writing by the parties. Modifications may result in additional fees and cannot be made without GE Healthcare’s prior written consent.

Handwritten or electronic modifications on this Agreement (except an indication of the form of payment, Customer purchase order number and signatures on the signature blocks below) are void.

Governing Agreement:	Novation Vizient Supply LLC
Terms of Delivery	FOB Destination
Billing Terms	80% delivery / 20% Installation
Payment Terms	NET 30
Total Quote Net Selling Price	\$1,754,072.50
Sales and Use Tax Exemption	Certificate on File

IMPORTANT CUSTOMER ACTIONS:

Please select your planned source of funds. Source of funds is assumed to be cash unless you choose another option. Once equipment has been shipped, source of funds changes cannot be allowed.

- Cash
- GE HFS Loan GE HFS Lease
- Other Financing Loan Other Financing Lease Provide Finance Company Name _____

The parties have caused this Agreement to be executed by their authorized representative as of the last signature date below.

Rutland Regional Medical Center

Signature: _____

Print Name: _____

Title: _____

Date: _____

Purchase Order Number, if applicable

GE Precision Healthcare LLC, a GE Healthcare business

Signature: Edwina Ashe

Title: Imaging Account Manager

Date: June 15, 2021

To Accept This Quotation

Please sign and return this quotation together with your Purchase Order to:

Name: Edwina Ashe

Email edwina.ashe@ge.com

Phone: (351) 209-0771

Fax:

Payment Instructions

Please **remit** payment for invoices associated with this quotation to:

GE Precision Healthcare LLC

P.O. Box 96483

Chicago, IL 60693

FEIN: 83-0849145

Rutland Regional Medical Center**Addresses:**

Bill To: RUTLAND REGIONAL MEDICAL CENTER

RUTLAND REGIONAL MEDICAL, CENTER 160 ALLEN ST
RUTLAND, VT, 05701-4560

Ship To: RUTLAND REGIONAL MEDICAL CENTER

CENTER 160 ALLEN ST RUTLAND, VT, 05701-4560

To Accept This Quotation

- Please sign the quote and any included attachments (where requested).
- If requested, please indicate your form of payment.
- If you include a purchase order, please make sure it references the following information:
The correct Quote number and Version number above
The correct Remit To information as indicated in **“Payment Instructions”** above
Your correct SHIP TO and BILL TO site name and address
The correct Total Price as indicated above

Upon submission of a purchase order in response to this quotation, GE Healthcare requests the following to evidence agreement to contract terms: Signature page on quote filled out with signature and P.O. number **** OR**** Verbiage on the purchase order must state one of the following:

(i) Per the terms of Quotation # _____, (ii) Per the terms of GPO # _____; (iii) Per the terms of MPA# _____; or (iv) Per the terms of SAA # _____.

Include applicable quote/agreement number with the reference on the purchase order. In addition, Source of Funds (choice of Cash/Third Party Load or GE HFS Lease Loan or Third Party Lease through _____), must be indicated, which may be done on the Quote Signature Page (for signed quotes), or the Purchase Order (where quotes are not signed) or via a separate written source of funds statement (if provided by GE Healthcare).”

Catalog Item Details

Line	Qty.	Catalog	
	1.00	S7529AH	SIGNA™ ARTIST 1.5T 96 CHANNEL 29.1 MR SYSTEM

The SIGNA™ Artist 1.5T 70cm wide-bore magnetic resonance system with SIGNA™Works AIR™ Edition (MR29.1) is designed to enable you to deliver both clinical excellence and operational efficiency while changing the MR experience for your patients and staff. With SIGNA™ Artist, put your patients at ease from start to finish with feet-first or head-first entry, Comfort Tilt head and neck positioning as well as free-breathing, motion forgiving and noise reduced exams. For your staff, simplify and accelerate the scanning process from set-up to acquisition to post-processing with access to an extensive range of clinical imaging and advanced visualization capability.

The SIGNA™ Artist system catalog comprises the system RF-architecture electronics, core RF coil suite, gradient electronics, patient table, computing platform, phantoms, and MR29.1 operating/imaging software:

- 96ch TDI RF-Receive Technology
- XP Gradient and Quiet Acoustic Reduction Technology
- Computing Platform and DICOM Conformance
- SIGNA™Works AIR™ IQ Edition Workflow with eXpress Detachable Table
- SIGNA™Works AIR™ IQ Edition Acceleration, Motion Correct and Tissue Suppression Technology
- SIGNA™ Works AIR™ IQ Edition Clinical Applications Toolkits
- SIGNA™ Works AIR™ IQ Edition READYView Advanced Visualization

To further enhance and extend the performance of SIGNA™ Artist, this offering also comprises:

- AIR x™ Auto Graphic Prescription for brain and knee
- AIR™ Recon DL and Gen& DL ICN Package
- Diffusion Package
- HyperWorks Package
- DISCO/DISCO Star & LAVA Star free-breathing body imaging

TECHNOLOGY FOUNDATION

The RF-architecture, gradient and computing technology on SIGNA™ Artist are designed to deliver the signal-to-noise, dynamic range, spatial resolution, temporal resolution and computational power needed to enable demanding clinical applications.

Total Digital Imaging (TDI)

SIGNA™ Artist features the Total Digital Imaging RF-architecture with an extended 96-channel configuration. The TDI RF-architecture uses a Direct Digital Interface (DDI) to convert the signal from each coil element to a digitized signal (there is no mixing of signal from multiple elements to the same digitizer) to deliver high signal, low noise with extended dynamic range or gray-scale capability.

Gradient and Quiet Technology

SIGNA™ Artist delivers high spatial and temporal resolution through efficient gradient coil design and a 3-axis gradient amplifier power supply. The gradients are non-resonant and actively shielded to minimize eddy currents and use an innovative digital control architecture designed to deliver high fidelity, accuracy and reproducibility over a large FOV.

- Peak amplitude per axis: 44 mT/m
- Up to 200 T/m/s instantaneous peak slew rate per axis
- Peak current and voltage: 830 Amps, 1650 Volts
- Digital PI feedback loop control
- Maximum FOV: 55 cm x 55 cm x 50 cm
- Duty Cycle: 100%

Designed to deliver an enhanced patient experience, SIGNA™ Artist features ART Quiet Acoustic Reduction Technology (ART) that significantly addresses both vibrational noise and airborne sound. ART Quiet acoustic reduction uses 5 levels of isolation, dampening and gradient optimization technology to mitigate vibration and mute sound.

- Gradient & RF coil isolation – isolates the resonance module from the magnet
- Vibro-acoustic isolation – isolates the magnet from the building
- Mass-damped acoustic barriers – further mutes sound
- Gradient waveform optimization – user selectable

Computing Platform and DICOM Conformance

SIGNA™ Artist utilizes a parallel, multi-processor design to enable simultaneous scanning, reconstruction, filming, post-processing, archiving and networking. Both the host computer and reconstruction systems use the Scientific Linux operating system. The host computer PC utilizes a single tower configuration and includes an LDC monitor and keyboard assembly with an integrated intercom speaker, microphone, volume controls, and emergency stop switch. Start scan, pause scan, stop scan and table advanced to center “hot” keys are also included.

- Host PC Platform: Intel Xeon W-2123 CPU
- Memory: 64 GB
- Hard Disk Storage: 1024 GB SSD
- Media Drives: CD/DVD

SIGNA™ Artist enhances data reconstruction with access to the Orchestra platform and Smart AIR™ Recon. The Orchestra computing toolbox enables the integration of advanced reconstruction elements to support demanding, data intense, applications as well as access to the product reconstruction algorithms. AIR™ Recon uses a smart reconstruction algorithm that reduces background noise and artifacts.

- Reconstruction Engine: Gen7 Dual Intel Xeon Gold 5118 with Performance Level
- Memory: >= 94 GB
- Hard Disk Storage: 960 GB SSD
- 2D FFT/second (256 x 256 Full FOV): 63,000 2DFFT/second
- Orchestra reconstruction toolbox
- Smart Algorithm AIR™ Recon

SIGNA™ Artist generates MR Image, Secondary Capture, Structured Report, and Gray Scale Softcopy Presentation State DICOM objects. The DICOM networking supports both send and query retrieve as well as send with storage commit to integrate with PACS archive. Please refer to the DICOM Compliance Statement for details.

SIGNA™WORKS AIR™ IQ EDITION WORKFLOW WITH eXpress DETACHABLE TABLE

The SIGNA™Works AIR™ IQ Edition workflow tools comprise the modality worklist, protocol libraries, workflow manager, auto-functions, inline viewing and inline processing. Together these tools are designed to change the way you work by simplifying and accelerating the scanning process from set-up to acquisition to post-processing. With SIGNA™Works, workflow can begin before the patient enters the magnet room and exams can be completed with a few mouse clicks delivering quality and consistency for all patients and from all technologists. At the same time, SIGNA™Works AIR™ workflow maintains the flexibility needed to rapidly adapt and optimize exams for specific patient situations including the ability to pause/resume a scan.

With AIR™ Workflow, scan set-up starts with the Modality Worklist, an automated method to obtain patient, exam and protocol information from a DICOM work-list server. For sites with full DICOM connectivity, once a patient has been selected from the Modality Worklist, the In-Room Operator Console will automatically highlight the relevant exam details. The Modality Worklist enables complete control of the MR protocol prescription, but also reduces work by allowing the MR protocol to be selected and linked to the patient record in advance of the patient’s arrival.

Protocol Tools enable exam automation while also giving the user complete control of protocols for prescription, saving, searching, and sharing. Protocols are organized into two libraries: GE Optimized (preloaded protocols) and Site Authored (customized and saved). Protocols can be saved based on patient demographics, anatomy, scan type, or identification number for rapid search and selection, and commonly used protocols can be flagged as favorites for quick selection from the Modality Worklist.

In addition to pre-programmed protocols, ProtoCopy enables a complete exam protocol to be shared with the click of a mouse. The GE protocols provided with the system also include Protocol Notes designed to guide the user through the procedure. For special applications, Protocol Notes also include video guides with step-by-step video-based demonstration and instruction. Protocol Notes can be edited by the user to reflect protocol modifications to aid communication among users.

In the scan room, the i-ROC In-Room Operator Console guides the technologist throughout patient set-up to the next workflow step and provides real-time feedback via integrated monitor and dual keypads – one on each site of the magnet. The i-ROC also enables the technologist to update patient data, confirm coil connection status and check waveforms without leaving the magnet room.

- Display of patient name, ID, study description
- Display and entry of patient weight
- Display and entry of patient orientation and patient position
- AIR Touch™ IntelliTouch landmarking
- Position the table, stop table movement and return table to home
- Display connected coils and coil status
- Display of table location and scan time remaining
- Control in-bore ventilation and lighting
- Cardiac waveform display and ECG/EKG lead confirmation with gating control for trigger selection
- Respiratory waveform display
- Control multiple level of in-bore ventilation and lighting
- Activate screen saver
- AutoStart to initiate scanning of the first series of the selected protocol

With the patient positioned, IntelliTouch and AIR Touch™ together simplify coil activation to one touch to landmark and one click to coil select. AIR Touch™ automatically determines coil element locations based on the IntelliTouch landmark and intelligently generates the coil configuration with elements activated to optimize image quality for coverage, uniformity and parallel imaging acceleration factor.

At the console, WorkFlow Manager implements the selected protocol. The WorkFlow Manager controls location prescription, acquisition, processing, visualization and networking, and can fully automate these steps, if requested by the user. Once the target anatomy has been prescribed, the Linking feature can be used to translate appropriate parameters to all subsequent series that have been linked, eliminating the need for further action by the user.

Auto Functions when selected can automatically initiate the localizer, coil selection, series-to-series scanning, multi-station scanning, prescription of scan plans for brain exams, as well as delivered instructions to the patient. Pause and Resume allows the user to pause a scan in progress (even in automated mode), to respond to a patient need, and then resume mid-scan (without starting over) helping to address rescans.

For multi-station exams, such as brain and spine, chest and body, lower leg run-offs, AIR™ Workflow streamlines localization and scanning. Whole Body Localizer automates the acquisition and pasting of multi-station scans for planning, and Whole-Body automated multi-station scanning can be performed with FSE-IR, 3D SPGR and DWI diffusion. Once scanning and processing are complete, Split Exam provides the capability to extract a subset of series from the exam and create/assign a separate exam number for accession numbers in billing and PACS systems.

Inline Processing automatically completes post-processing steps for the user after the images have been reconstructed and saved into the database. For certain tasks, such as vascular segmentation, the user must accept the results, or complete additional steps prior to saving the images to the database. These automated processing steps can be saved to the (scan) protocol to ensure consistent output and workflow:

- Diffusion weighted series: automatic compute and save
- Diffusion tensor series: automatic compute and save
- eDWI: automatic compute and save
- Image filtering: automatic compute and save
- Maximum/Minimum Intensity Projection: automatic compute and save
- Pasting: automatic compute and save
- Reformat to orthogonal plane: automatic compute and save
- T2 map for cartilage: automatic compute and save
- 3D Volume Viewer: automatic load
- Image Fusion: automatic load
- Interactive Vascular Imaging: automatic load
- FiberTrak: automatic load
- Spectroscopy: automatic load

SIGNA™WORKS AIR™ IQ EDITION CLINICAL APPLICATIONS TOOLKITS

The SIGNA™Works AIR IQ Edition is designed to change the way you work by simplifying and accelerating the scanning process from set-up to acquisition to post-processing while delivering access to a broad range of clinical imaging capability. The AIR™ IQ Edition of SIGNA™Works comprises the operating software, pulse sequence families, clinical applications and visualization toolkits as well as acceleration, motion correction and tissue suppression technology.

The acceleration, motion correction and tissue suppression tools in the SIGNA™Works AIR™ IQ Edition are designed to address overall workflow, rescans and scan time as well as the impact of challenging patients, challenging anatomy and challenging physiology.

Acceleration Technology

Reduce scan set-up and acquisition time with a suite of techniques highlighted by AIR™ Workflow, parallel imaging and partial k-space techniques. Many techniques can be used in combination for additive effects.

- AIR Touch™ intelligent activation reduces set-up time by reducing coil selection and optimization to one finger touch and one mouse click. AIR™ Touch then activates coil elements based on the anatomy, FOV and ARC parallel imaging factor.
- AIR™ Recon is a smart reconstruction algorithm that reduces background noise and artifacts enabling enhanced image quality without the need for longer scan times. AIR™ Recon is compatible with a broad range of imaging sequences including: the FSE fast spin echo, 3D Cube fast spin echo, SPGR/FSPGR, GRE/FGRE, PROPELLER MB, eDWI, FOCUS DWI, FIESTA, Black Blood, Time Course, MDE, SSMDE and StarMap.
- ARC parallel imaging reduces scan time using an auto-calibrating (data-driven) technique. ARC selectively acquires data using an adaptive algorithm. As a result, ARC enables smaller FOV prescription with less sensitivity to motion and prevents coil calibration artifacts.
- ASSET parallel imaging reduces scan time using an array spatial sensitivity (image driven) technique. ASSET takes advantage of the data produced by the multiple coil elements to reduce the total data needed.
- Flexible No Phase Wrap reduces scan time by reducing the number of increments acquired based on a flexible user-selectable factor.
- Fraction NEX reduces scan time by reducing the number of data averages.

Motion Correction Technology

Enable free-breathing body exams and address the effects of motion with patient-adaptive technologies that proactively detect and correct for motion without hardware dependencies or the need for user intervention.

- Auto Body Navigators deliver real-time, respiratory motion compensated imaging for a broad range of sequences, including T1w dynamic contrast-enhanced imaging. Auto Body Navigators use a software-based tracking pulse that is automatically placed for the user and allows on-the-fly adjustment to adapt to challenging patient circumstances, again without the need for hardware or sensors.
- PROPELLER MB combines radial acquisition and motion correction post-processing to mitigate the effects of motion without the need to position the patient over a sensor. PROPELLER MB can be used to generate T1, T2, PD, T1 FLAIR, and T2 FLAIR contrasts and is compatible with FatSat, ASPIR, STIR T1 and Auto Body Navigators to enable usage for a broad range of exams.

Tissue Suppression Technology

Modify the contribution of fat or water signal with multiple tissue suppression techniques.

- FatSat uses a frequency selective pulse to target and suppress the signal from fat.
- STIR uses an inversion pulse to null either the signal from fat or water based on the timing of the pulse.
- SPECIAL essentially combines FatSat and STIR by using a frequency selective inversion pulse that targets and suppresses the signal from fat.
- ASPIR enhances fat suppression by using a spectrally selective (instead of a single frequency) inversion pulse to null the signal from fat.
- IDEAL is a 3-point Dixon technique that separates the signal from fat and water based on phase shift and enables the generation of water-only, fat-only, in-phase and out-of-phase images.
- Flex is 2-point Dixon techniques that separates the signal from fat and water based on phase shift and enables the generation of water-only, fat-only, in-phase and out-of-phase images.

The SIGNA™Works AIR™ IQ Edition clinical imaging tools are organized and optimized to address six clinical work areas: NeuroWorks, OrthoWorks, BodyWorks, OncoWorks, CVWorks and PaedWorks.

NeuroWorks comprises pre-programmed protocols, clinical applications and visualization tools designed for the challenges of brain and brachial plexus imaging. Resulting capability starts with simplified prescription and protocol set-up. Imaging capability extends to sensor-free motion correction, advanced volumetric imaging, enhanced diffusion, susceptibility assessment and selective tissue suppression techniques. Post-processing capability augments the portfolio with 3D multi-planar reformat, volume segmentation/rendering, diffusion assessment and dynamic contrast-enhanced assessment.

- READYBrain auto-align for automated brain exam prescription
- PROPELLER MB motion robust radial-FSE with T1, PD, T2, T2 FLAIR, T1 FLAIR with STIR and ASPIR
- PROPELLER DW Duo FSE-based diffusion with susceptibility reduction
- Flex 2-point Dixon fat-water separation for 2D FSE and 3D Cube
- 3D Cube 2.0 FSE-based imaging with T1, T2, T1 FLAIR, T2 FLAIR and STIR
- 3D Cube Dual Inversion Recovery for gray or white matter nulling

- 3D COSMIC modified steady state imaging
- 2D/3D MERGE T2* multi-echo fast gradient echo imaging
- 3D BRAVO IR prepared fast SPGR imaging with concentric k-space filling
- 3D MP-RAGE IR prepared fast SPGR imaging with sequential k-space filling
- 3D FIESTA and 3D FIESTA-C fast steady state imaging
- eDWI enhanced diffusion with Multi-B value and SmartNEX
- DTI diffusion tensor imaging
- FiberTrak post-processing for diffusion tensor
- 3D SWAN 2.0 GRE-based multi-echo susceptibility imaging
- PROBE PRESS single voxel spectroscopy
- BrainStat GVF and AIF parametric maps
- READYView and BrainView post-processing

OrthoWorks delivers pre-programmed protocols, clinical applications and visualization tools designed for the challenges of joint, long bone and spine imaging. Resulting capability starts with fast-spin echo techniques as the foundation for articular cartilage, ligaments, menisci and sub-chondral bone imaging. Imaging capability also extends to sensor-free motion correction, advanced volumetric imaging, selective tissue suppression, cartilage assessment and spectral imaging for MR-Conditional implants. Post-processing capability augments the portfolio with 3D multi-planar reformat, volume segmentation/rendering and T2 cartilage mapping.

- FSE and frFSE fast spin echo imaging suites with dynamic phase correction
- FatSat, STIR, SPECIAL, ASPIR, Spectral Spatial fat-suppression tools
- MARS High Bandwidth distortion reduction for FSE
- MAVRIC SL FSE-based spectral imaging for MR-Conditional implants with T1, PD, T2 and STIR
- PROPELLER MB motion robust radial FSE with T1, PD, T2 and Fat Suppression (STIR and ASPIR)
- 3D Cube 2.0 FSE-based imaging with T1, T2, and STIR
- Flex 2-point Dixon fat-water separation for 2D FSE and 3D Cube
- 3D COSMIC modified steady state imaging
- 2D/3D MERGE T2* multi-echo fast gradient echo imaging
- CartiGram T2 cartilage mapping
- READYView post-processing

BodyWorks delivers pre-programmed protocols, clinical applications and visualization tools designed for the challenges of imaging the upper abdomen, liver, male pelvis and female pelvis. Resulting capability starts with sensor-free motion correction and navigators that enable the ability to conduct free-breathing exams with a broad range of contrast weighting capability. Imaging capability further extends to snap-shot imaging, volumetric MRCP imaging, dynamic volumetric imaging, enhanced diffusion, iron deposition and selective tissue suppression techniques. Post-processing capability augments the portfolio with 3D multi-planar reformat and high-definition maximum/minimum intensity pixel projection.

- Auto Navigators diaphragm tracker for free-breathing scanning
- PROPELLER MB motion robust radial FSE with T1 and Fat Suppression (STIR and ASPIR)
- 3D Cube FSE-based imaging with T1, T2, and STIR
- eDWI enhanced diffusion with Multi-B value and SmartNEX
- 3D Dual Echo gradient echo in/out phase imaging
- 3D LAVA and Turbo LAVA with Turbo ARC and SPECIAL for dynamic or single-phase imaging
- 3D LAVA Flex GRE 2-point Dixon fat-water separation for dynamic or single-phase imaging
- IDEAL FSE 3-point Dixon fat-water separation
- Flex GRE 2-point Dixon fat-water separation
- 3D MRCP frFSE imaging
- 2D Fat Sat FIESTA fast steady state imaging
- Enhanced SSFSE Snapshot multi-slice imaging with SmartR
- Whole-Body multi-station localizer and pasting
- Whole-Body multi-station FSE-IR, 3D SPGR and DWI imaging
- StarMap iron assessment for liver and heart (acquisition)
- Multiphase DynaPlan
- SmartPrep automated bolus detection
- Fluoro Trigger real-time bolus monitoring
- READYView and BodyView post-processing

OncoWorks delivers pre-programmed protocols, multi-station, contrast-timing, clinical applications and visualization tools designed for the challenges of imaging throughout the brain, spine and body. Resulting capability starts with tools that simplify and streamline the steps associated with multi-station acquisition and the timing of contrast delivery. Imaging capability includes sensor-free motion correction and navigators that enable the ability to conduct free-breathing exams with a broad range of contrast weighting capability.

Capability further extends to snap-shot imaging, dynamic volumetric imaging, enhanced diffusion and selective tissue suppression techniques. Post-processing capability augments the portfolio with 3D multi-planar reformat, volume segmentation/rendering, diffusion assessment and auto-contour.

- Auto Navigators diaphragm tracker for free-breathing scanning
- PROPELLER MB motion robust radial-FSE with T1, PD, T2, T2 FLAIR, T1 FLAIR with STIR and ASPIR
- PROPELLER DW Duo FSE-based diffusion imaging with susceptibility reduction
- Flex 2-point Dixon fat-water separation for 2D FSE and Cube
- 3D Cube 2.0 FSE-based imaging with T1, T2, T1 FLAIR, T2 FLAIR and STIR
- 3D Cube Dual Inversion Recovery for gray or white matter nulling
- 3D BRAVO IR prepared fast SPGR imaging with concentric k-space filling
- 3D MP-RAGE IR prepared fast SPGR imaging with sequential k-space filling
- Enhanced SSFSE Snapshot multi-slice imaging with SmartR
- Whole-Body multi-station localizer and pasting
- Whole-Body multi-station FSE-IR, 3D SPGR and DWI imaging
- eDWI enhanced diffusion with Multi-B value and SmartNEX
- 3D LAVA and TurboLAVA with Turbo ARC and SPECIAL
- 3D LAVA Flex GRE 2-point Dixon fat-water separation for dynamic or single-phase imaging
- Multiphase DynaPlan
- SmartPrep automated bolus detection
- Fluoro Trigger real-time bolus monitoring
- READYView, BrainView and BodyView post-processing

CVWorks delivers pre-programmed protocols, multi-station, contrast-timing, clinical applications and visualization tools designed for the challenges of imaging vascular structures and the heart. Resulting capability starts with tools that simplify and streamline the steps associated with multi-station acquisition and the timing of contrast delivery. Imaging capability includes sensor-free navigators that enable the ability to conduct free-breathing exams. For MRA, imaging capability includes 2D and 3D time-of-flight and phase contrast MRA, non-contrast MRA and dynamic MRA techniques. For the heart, imaging capability includes techniques for morphology, function, tissue characterization and iron deposition. Post-processing capability augments the portfolio with interactive vascular imaging for MRA and high-definition maximum/minimum pixel projection.

- Auto Navigators diaphragm tracker for free-breathing scanning
- iDrive for free breathing cardiac planning
- 2D FIESTA Cine gated steady-state, multi-phase imaging
- 3D FS FIESTA steady-state imaging with Fat Sat
- 2D/3D IR Prep gated fast gradient echo imaging
- Black Blood SSFSE single-shot FSE-based imaging
- Cine IR fast-gradient echo cardiac cine imaging with IR-prep pulse
- 2D/PS MDE phase sensitive tissue characterization
- StarMap iron assessment for liver and heart (acquisition)
- 2D/3D Time-Of-Flight & 2D Gated Time-of-Flight
- 2D/3D Phase Contrast & Phase Contrast Cine
- TRICKS dynamic contrast enhanced 3D MRA
- Inhance 2.0 non-contrast MRA suite
- SmartPrep automated bolus detection
- Fluoro Trigger real-time bolus monitoring
- 3D QuickStep automated multi-station imaging
- READYView post-processing

PaedWorks delivers pre-programmed protocols, clinical applications and visualization tools designed for the challenges of imaging pediatric patients. Resulting capability starts with sensor-free motion correction and navigators that enable the ability to conduct free-breathing exams with a broad range of contrast weighting. Imaging capability further extends to advanced volumetric imaging, dynamic volumetric imaging, enhanced diffusion, susceptibility assessment, selective tissue suppression techniques and spectral imaging for MR-Conditional implants. Post-processing capability augments the portfolio with 3D multi-planar reformat, volume segmentation/rendering and diffusion assessment.

- PROPELLER MB motion robust radial-FSE with T1, PD, T2, T2 FLAIR, T1 FLAIR with STIR and ASPIR
- 3D Cube 2.0 FSE-based imaging with T1, T2, T1 FLAIR, T2 FLAIR and STIR
- 3D Cube Dual Inversion Recovery for gray or white matter nulling
- 3D COSMIC modified steady state imaging
- 2D/3D MERGE T2* multi-echo fast gradient echo imaging
- 3D BRAVO IR prepared fast SPGR imaging with concentric k-space filling

- 3D MP-RAGE IR prepared fast SPGR imaging with sequential k-space filling
- 3D FIESTA and 3D FIESTA-C fast steady state imaging
- eDWI enhanced diffusion with Multi-B value and SmartNEX
- DTI diffusion tensor imaging
- FiberTrak post-processing for diffusion tensor
- SWAN 2.0 3D GRE-based multi-echo susceptibility imaging
- PROBE PRESS single voxel spectroscopy
- MAVRIC SL FSE-based spectral imaging for MR-Conditional implants
- Auto Navigators diaphragm tracker free-breathing scanning
- 3D LAVA and Turbo LAVA with Turbo ARC and SPECIAL for dynamic or single-phase imaging
- 3D LAVA Flex GRE 2-point Dixon fat-water separation for dynamic or single-phase imaging
- Enhanced SSFSE Snapshot multi-slice imaging with SmartR
- Black Blood SSFSE single-shot FSE-based imaging
- Cine IR fast-gradient echo cardiac cine imaging with IR-prep pulse
- 2D PS/MDE phase sensitive tissue characterization
- StarMap iron assessment for liver and heart (acquisition)
- BrainStat GVF and AIF parametric maps
- READYView and BrainView post-processing

Advanced Visualization and Post-Processing

READYView is a SIGNA™ Works AIR™ IQ Edition advanced visualization tool designed to simplify the quantitative analyses of multiple data sets. READYView automatically selects the most relevant post-processing protocol for the user and provides guided workflow and general assistance for the processing algorithms. In addition, the user can customize workflows with adjustable layouts, personalized parameter settings and custom review steps. Key capabilities of READYView include the ability to analyze, export and save:

- Time series
- Diffusion weighted series
- Diffusion tensor series
- Variable echo series
- Blood oxygen level dependent (BOLD) series fMRI processing
- Spectroscopy data (single voxel and 2D or 3D CSI)
- MR Touch (MR elastography) series

AIRx™ AUTO GRAPHIC PRESCRIPTION

Change the way you prescribe brain and knee exams. AIR x™ Auto Graphic Prescription uses deep learning algorithms, instead of an atlas-based method, to automatically identify anatomical structures and prescribe slice locations for brain and knee exams. As a result of the deep learning algorithms, AIRx™ automatically adapts slice prescriptions to various patient anatomies and structures to enable consistency and productivity for slice positioning from technologist to technologist, patient to patient and the same patient overtime.

AIR™ RECON DL AND DL RECONSTRUCTION ENGINE

Level-up your image quality. AIR™ Recon DL is a deep learning-based reconstruction algorithm that utilizes trained neuro networks to remove noise and ringing artifacts from the raw scan data. As a result, AIR™ Recon DL delivers images with enhanced SNR and sharpness while also enabling the reduction in scan time and resulting exam time. AIR™ Recon DL is directly embedded in the reconstruction pipeline to address image quality at the foundation level to produce TrueFidelity images (and therefore is not a traditional filter or a post-processing technique). AIR™ Recon DL is compatible with most 2D applications and select diffusion-weighted EPI sequences.

- Intelligent pipeline reconstruction produces TrueFidelity images
- Reduces image noise at the foundation level
- Reduced Gibbs and truncation artifacts at the foundation level with intelligent ringing suppression
- Reduces scan time and resulting exam times
- Tailor level based on preference

To support the computational intensity of AIR™ Recon DL, this offering package includes the Gen7 DL ICN reconstruction engine with enhanced performance.

ADVANCED DIFFUSION PACKAGE

Extend diffusion capability. The Diffusion Package delivers techniques that reduce distortion, correct for motion and increase spatial resolution and performance for diffusion and diffusion tensor imaging.

- PROGRES distortion and motion correction for diffusion
- MUSE multi-shot high-resolution diffusion
- FOCUS DWI 2D slice-selective high-resolution diffusion
- MAGiC DWI diffusion-based synthetic multiple b-value imaging

HYPERWORKS ACCELERATION

The HyperWorks toolkit comprises a new generation of acceleration tools that employ a variety of optimized approaches to accelerate imaging for a broad range of exams.

- HyperSense 2.0 compressed sensing
- HyperCube tailored RF
- HyperBand simultaneous slice excitation
- HyperMAVRIC SL accelerated spectral imaging

DISCO STAR & LAVA Star

DISCO Star enables the option of free-breathing dynamic abdominal imaging for patients with limited breath-hold capability or patients who are unable to follow breathing instructions. DISCO Star uses an in-plane radial acquisition trajectory to provide active motion compensation, without navigators or bellows, to address both set-up time and rescans due to motion artifacts. The offering also includes LAVA Star, which provides the same motion robust, free-breathing scan for single phase (pre-contrast or delayed) imaging.

Line	Qty.	Catalog	
	1.00	M7110HD	SIGNA Artist 1.5T Magnet Collector

To improve the patient experience and provide high image quality, no other component of an MRI system has greater impact than the magnet. The SIGNA Artist 1.5T system features a wide bore magnet that delivers a large field of view. The magnet geometry has been optimized to reduce patient anxiety by providing more space in the bore and more exams with the patient's head outside of the magnet. The 55cm field of view (50cm in Z direction) provides uniform image quality and can reduce exam times since fewer acquisitions may be necessary to cover large areas of anatomy. Complemented by GE's active shielding technology, the Artist has very flexible installation specifications to provide easy siting. And with zero-boil-off magnet technology, helium refills are effectively eliminated, thus reducing operating costs and maximizing uptime.

Magnet:

- Manufactured by GE Healthcare.
- Operating field strength 1.5T (63.86 MHz).
- Active magnet shielding
- Zero boil-off Cryogenics.
- Magnet length 179cm.
- Patient Aperture 76 cm.
- Patient Bore Diameter 70cm.
- Patient Bore Length 105cm.
- Maximum Field of View 55 cm x 55 cm x 50 cm.

Magnet Homogeneity: Typical ppm and Guaranteed ppm shown.

- 10cm DSV 0.007 and 0.02.
- 20cm DSV 0.035 and 0.06.
- 30cm DSV 0.10 and 0.15.
- 40cm DSV 0.33 and 0.43.
- 45cm DSV 0.88 and 1.0.
- 48cm DSV 1.75 and 2.0.
- 50cm DSV 2.8 and 3.3.

DSV = Diameter Spherical Volume.

Fringe field (axial x radial):

- 5 Gauss = 4.0 m x 2.5 m.
- 1 Gauss = 5.8 m x 3.2 m.

Quiet Technology:

GE has implemented Quiet Technology on critical components of the Optima MR system to reduce acoustic noise and improve the patient environment. This technology enables full use of the eXtreme Gradient Platform for excellent image quality, while maintaining a safe environment for the patient. The technology encompasses the gradient coil, RF body coil, and magnet mounting.

Line	Qty.	Catalog	
	1.00	S7505EK	Preinstallation Collector and Cable Concealment Kit

The Preinstallation Collector delivers to the site in advance of the magnet and main electronic components. This facilitates the later delivery and installation of supporting electronics. The following are the main components in the Preinstallation collector:

- Heat exchange cabinet for distribution of chilled water.
- Primary Penetration wall panel for support of the penetration cabinet.
- Secondary Penetration wall panel for support of gradient filters, helium cables, and chilled air and water.
- Helium cryocooler hose kit.

The Cable Concealment Kit accommodates a wide-range of scan room ceiling heights and is designed to provide a clean-look installation by concealing the overhead cabling from view.

Line	Qty.	Catalog	
	1.00	M6001AA	Vent Adapter, Standard 8" Straight Up

Vent Adapter, Standard 8" Straight Up

Line	Qty.	Catalog	
	1.00	M7006CF	SIGNA Artist 1.5T Cable Collector - A

SIGNA Artist 1.5T Cable Collector - A

Line	Qty.	Catalog	
	1.00	M7007YS	Artist Gradient Cables Config A

Artist Gradient Cables Config A

Line	Qty.	Catalog	
	1.00	M7000ZA	Main Disconnect Panel

The Main Disconnect Panel safeguards the MR system's critical electrical components, by providing complete power distribution and emergency-off control.

Line	Qty.	Catalog	
	1.00	M1000MW	Operator Console Table

The Operator Console Table is designed specifically for the color LCD monitor and keyboard.

Line	Qty.	Catalog	
	1.00	M3335JZ	English Keyboard

Required for our operator console. This keyboard is ergonomically designed to keep your staff comfortable even through the longest shifts. The scan control keyboard assembly has an intercom speaker, microphone, volume controls and emergency stop switch.

Line	Qty.	Catalog	
	1.00	R32052AC	Standard Service License

The Standard Service License provides access to service tools used to perform basic level service on the Equipment and is included at no charge for the warranty period.

Line	Qty.	Catalog	
	1.00	S7529SE	LIVER HEALTH FOR 1.5T

The Liver Health package for 1.5T enables non-invasive assessment of the liver via the quantification of liver fat and relative tissue stiffness. IDEAL IQ uses a Dixon technique to separate fat and water, based on the phase shift, to enable quantitative assessment of the triglyceride fat content in the liver. IDEAL IQ delivers 3D whole liver coverage in a single breath-hold to provide whole-organ assessment. MR Touch combines an echo-planar based sequence synchronized with mechanically induced liver vibration to acquire a series of images where the phase contrast is related to the shear stiffness of the soft tissue. Post-processing generates a relative stiffness map, Elastogram, and wave images from the phase contrast images.

- IDEAL IQ triglyceride fat quantification
- MR Touch relative liver stiffness assessment

Line	Qty.	Catalog	
	1.00	S7529SK	BREAST IMAGING WITH 16CH ARRAY FOR 1.5T - NeoCoil

The breast imaging package combines VIBRANT acquisition with the 1.5T 16ch breast array by NeoCoil to enable imaging and MR-guided biopsy of the breast. VIBRANT delivers simultaneous bilateral breast imaging capability with high spatial and high temporal resolution in either the axial or sagittal plane. In addition, VIBRANT combines dual-shim volume ability with the choice of SPECIAL fat suppression or Flex fat-water separation for robust fat suppression. The 16ch breast coil is designed to be used in conjunction with VIBRANT for imaging the breast, axilla and chest wall at 1.5T. The coil is a phased array with 16-channel receive and is designed to accommodate various anatomic shapes and sizes while providing enhanced SNR and parallel imaging performance. The 16ch breast array supports both diagnostic and biopsy imaging.

- 3D VIBRANT bilateral axial or sagittal breast imaging
- 16-channel breast phased array for 1.5T by NeoCoil

Line	Qty.	Catalog	
	1.00	M7006AC	CardioMap

CardioMap with T1 and T2 cardiac mapping delivers parametric maps with integrated motion correction of the myocardium.

CardioMap includes the following sequences:

- MOLLI
- SmartT1 Maps (GE Exclusive)
- T2 Mapping

Line	Qty.	Catalog	
	1.00	M7110NA	SIGNA™ ARTIST 1.5T AIR™ COILS SUITE AND PATIENT TABLE (HNU, PA, AA, T/R Head)

The SIGNA™ Artist coil suite is designed to enhance patient comfort and image quality while simplifying workflow. The suite includes:

- Integrated T/R Body Coil
- T/R Head Coil
- TDI Posterior Array
- TDI Head-Neck Unit with Comfort Tilt
- AIR™ Anterior Array

The TDI Posterior Array is designed to provide optimal element geometry for each targeted anatomy by using different element geometries for the cervical-to-thoracic spine transition, thoracic and lumbar spine, and the body. The PA coil is designed to be used in conjunction with the HNU, Anterior Array and the PV Array (sold separately). The PA coil is embedded in the Express detachable table and is invisible to additional surface coils when they are placed directly on top of the surface.

- Elements: 40
- Length: 100 cm; Width: 40cm
- S/I coverage: 100cm head-first or feet-first
- Parallel imaging in all three scan planes
- Head-first or feet-first positioning

The TDI Head and Neck Unit comprises the baseplate and three anatomically optimized anterior arrays: the anterior Neuro-vascular array, the anterior cervical spine array, the anterior open-face array. The HNU may be positioned at either end of the Express table to support head-first or feet-first imaging and may remain in place for all body, vascular, spine, and most MSK exams. The HNU baseplate supports the patient's head, and the Comfort Tilt variable-degree ramp can be positioned under the HNU base plate to elevate the coil to match the patient's head and neck position.

- Elements: up to 28 combined with PA and AA
- Length: 49.5 cm; Width: 38.8 cm
- Height with NV Array: 36.8 cm
- Height with Cervical Array: 33.6 cm
- Height with Open Array: 25.7 cm
- S/I coverage: up to 50 cm with PA and AA
- Parallel imaging in all three scan planes
- Head-first or feet-first positioning

The AIR™ Anterior Array is a next generation array that allows flexibility in any direction to conform to the patient's anatomy. Based on INCA conductor and the E-mode module innovative technologies, the 30ch AIR™ AA provides superb SNR and acceleration performance, while improving the overall patient and user experience. The coil has been designed to adapt to various patient shapes and sizes, with an ultra-lightweight distribution of less than 0.35 grams/cm².

- Elements: 30
- Channels: 45 with PA; 121 with PA, HNU and second AA
- Length: 79 cm; Width: 66 cm
- Height: 1.2 cm
- S/I coverage: up to 63 cm
- R/L coverage: up to 60 cm

- Parallel imaging in all three scan planes
- Head-first or feet-first positioning

EXPRESS DETACHABLE TABLE

SIGNA™ Artist eXpress Patient Table is a crucial part of AIR™ Workflow. The eXpress table is a mobile patient transport device that houses the TDI Posterior RF Array and touch sensitive IntelliTouch land-marking. The fully detachable table is easily docked and undocked by a single operator and moved in and out of the exam room for patient transport and preparation. The eXpress table and embedded PA coil are designed to accommodate head-first or feet-first imaging for all supported exams.

- Maximum patient weight for scanning: 500 lbs
- Maximum patient weight mobile: 500 lbs
- Maximum patient weight for lift: 500 lbs
- 205 cm symmetrical scan range
- Automated vertical and longitudinal power drive
- Fast longitudinal speed: 30 cm/second
- Slow longitudinal speed: 0.5 cm/second
- Integrated arm boards & non-ferrous IV pole
- IntelliTouch & laser land-marking
- Laser alignment land-marking

Line	Qty.	Catalog	
	1.00	M7006CE	1.5T 16-Channel T/R Hand-Wrist Coil

The 1.5T 16-Ch T/R Hand Wrist Coil is a transmit and receive MRI RF coil intended for obtaining diagnostic images of patient hand and wrist anatomies. The coil consists of two saddle coils driven in quadrature capable of both transmitting and receiving, along with an array of sixteen surface receive elements. The transmit coil consists of two orthogonal saddles, which is a volume transmit coil for transmitting RF magnetic field into human tissue during transmit phase, and can function as a receive coil for receiving MRI signal from human tissue during receive phase. The device includes two rigid, plastic bases which the coil can be attached to and removed as desired. One positions the coil for horizontal wrist imaging, and one positions the coil for vertical wrist imaging. In the horizontal position, position of the coil can be adjusted along the base to accommodate imaging of either the left or right hand. Foam pads are also provided as accessories to aid in patient immobilization, anatomy positioning, and to enhance patient comfort.

Compatible only with MR systems that have 32-channels or more. Not compatible with 16-channel systems. Requires software 26.0 R02 or higher for DV products and 26.2 or higher for Voyager.

Line	Qty.	Catalog	
	1.00	M7100SG	1.5T 16-channel Shoulder Coil by NeoCoil

The 1.5T Shoulder Coil by NeoCoil consists of a soft and light anterior array paired with a formed posterior array that together are designed to aid flexible patient positioning and heightened comfort. The coil is a phased array design with 16-channel receive and parallel imaging compatibility to also deliver enhanced SNR and speed for shoulder imaging at 1.5T.

- Elements: 16
- Dimensions: 28.2 cm x 35.3 cm x 18.2 cm
- Weight: 3.0 kg
- Parallel imaging compatible

Line	Qty.	Catalog	
	1.00	M7001NL	1.5T 16-Channel T/R Knee Array

The 1.5T 16-channel Knee Array is a transmit/receive coil that produces high resolution images of the knee and is optimized for parallel imaging in all three directions to reduce acquisition times.

Line	Qty.	Catalog	
	1.00	M7006YJ	1.5T AIR™ Multi-Purpose Coil Large & Medium with Positioners

A package includes 1.5T AIR™ Multi-Purpose (MP) Coils, Large and Medium, with a coil positioner kit.

The 21-channel 1.5T AIR Multi-purpose (MP) Large and The 20-channel 1.5T AIR MP Medium are the next generation multipurpose coils that allow flexibility in any direction to conform to the patient's anatomy. Based on the innovative AIR™ Coil technologies, those 1.5T AIR™ MP Coils provide good image quality and acceleration performance, while improving the overall patient and user experience. Those coil have been designed to adapt various patient shapes and sizes, expanding positioning versatility. AIR™ MP Coil Large is recommended to be used for Shoulder, Forearm, Prostate, Hip/bony pelvis, Knee (large patients), Long bone, Foot/ankle. AIR™ MP Coil Medium is recommended to be used for Cardiac, Elbow, Hand/wrist, Knee (small patients), Forefoot.

The AIR™ MP Coil positioner kit includes a knee positioner, a foot-ankle positioner, a wedge pad, a u-shaped pad and a strap kit. Those are compatible with both AIR™ MP Coils Large and Medium for positioning.

Line	Qty.	Catalog	
	1.00	E8800XA	NeoCoil Sentinel G1 Wireless Music System for MRI Systems

The NeoCoil Wireless Audio/Music system provides audio entertainment and facilitates communications between the patient and technologist. Wireless solution eliminates multiple cords and standard 3.5mm audio jack allows any compatible music source. Integrates audio entertainment, the technologist's voice, and AutoVoice for optimum patient communication
 MR Conditional wireless audio system for use with high field MRI up to 3.0T
 Dramatically attenuates gradient noise
 When the technologist uses the intercom or when the feature AutoVoice is used, the music is interrupted for clear communication
 Wireless solution operates on 3 batteries

Package includes:

- Wireless 29dB headphones (over-ear)...uses 2 battery packs
- Wireless airtube/earbud assembly (in-ear)...uses 1 battery pack
- Disposable 29dB earbud inserts, 125 pair (250/box)
- Battery charging dock (can wall mount or desk; charges up to 4 batteries in under 6 hours)
- Audio cable, 3.5mm
- (3) Individual Li-Po 3.7V Battery Packs (rated for 12 hours continuous use)
- Transmitter and console interface - wall-mounted transmitter including couplers for penetration panel (2.4 GHz ISM band)
- Audio Source - Amazon® Fire® tablet, tablet stand, tablet lock, and (2) speakers

GE MRI compatibility:

Compatible with all MRI systems including Creator/Explorer v25.3 and Pioneer hardware v26.1

Line	Qty.	Catalog	
	1.00	E8800XH	Neocoil Individual battery pack NeoCoil Individual Li-Po 3.7V Battery Pack for Sentinel G1

- Removable battery pack for use with NeoCoil wireless system
- Rechargeable Li-Po 3.7 V
- 1000 mAh
- 12 hours of continuous use
- Complete system (E8800XA and E8800XK) already includes this item
- Expected life of approximately 1 year

Line	Qty.	Catalog	
	1.00	E8822JB	Sanitary Covers for Headset - 1000/Box

Sanitary covers for audio headsets. Packaged 1000 units per box.

Line	Qty.	Catalog	
	1.00	E8912CA	Dimplex MR Heat Exchanger 49kW - Standard Ambient Temp

GE Heat Exchangers - 49kW (20Tons)

Cooling for your GE Healthcare MR system has never been so easy. GE Healthcare has partnered with the Glen Dimplex Group, a world leader in cooling systems, to offer heat exchangers designed to meet the needs of your MR System. Now you can look to GE Healthcare for your entire MR purchase and support.

This heat exchanger is highly reliable and the only unit verified to perform with the new platform of GE Healthcare MR systems. As part of your integrated GE Healthcare solution, you'll work with a single contact throughout the whole installation. A Project Manager of Installation will help with building layout, room designs, delivery and installation - every step until your system is ready to scan. Our team will work seamlessly with architects, contractors and your internal team to help ensure timely, cost-effective completion.

Once your cooling system is running, you'll get fast, highly-skilled service support managed through GE Healthcare - with the same quality and response time you expect from your MR system.

FEATURES AND BENEFITS

- Designed to provide stable fully dedicated cooling for your MR system's needs
- Water/glycol outdoor-air-cooled heat exchangers to support your highest exam volumes and your full range of diagnostic procedures
- Redundant fluid pumps with automatic switchover let you keep operating with no loss of cooling even if one pump goes down
- Quad compressor, dual tandem refrigeration circuit design saves on energy while your system smoothly transitions through the 10% to 100% heat load capacity cycles of patient scanning and idling
- Quiet operation between patient exams and overnight - ideal for facilities in residential areas
- Comes with installation support, installation visits, preventative maintenance visit and 1 full year of parts and labor warranty
- Installation support includes: support through GE's Project Manager of Install, GE's Design Center, technical support from the Glen Dimplex company, two (2) installation visits
- Comprehensive and quality service rapidly delivered through our CARES service solution
- 65 gallons of 100% glycol concentrate for complete system filling and diluting
- Wall mounted remote display panel provides the ability to monitor the system's operation and indicates possible system errors
- Filter kit with flow meter helps to ensure purity of water prior to entry to the MR system
- Highly recommended that Vibration Isolation Spring Kit (E8911CJ) be added for systems that will be roof top mounted

SPECIFICATIONS

- Net Cooling Capacity: 49 kW / 20 Ton
- Maximum Coolant Flow: 35 gpm (132 l/m)
- Coolant Outlet Temperature: 48 F (8.9 C)
- Coolant Temp Stability: E 1.8 F (E1.0 C)
- Max Coolant Pressure : 70 Psi (4.8 Bar)
- Refrigerant: R407C
- Ambient Temp Range: -20 to 120 F (-30 to 50 C)
- Condenser Air Flow (Approx): 18,000 Cfm
- Tank Capacity: 100 gal (378 l)
- Flow Meter Range: 4-40 gpm
- Filters: 50 micron cartridge filters
- Supply Voltage: 460v / 3 phase / 60 Hz
- Coolant Connections: 2" NPTF
- Overall Size (L x W x H) 44" x 136" x 84.5"

COMPATIBILITY:

- GE MR450w or MR System NOTE: Item is NON-RETURNABLE and NON-REFUNDABLE

Line	Qty.	Catalog	
------	------	---------	--

1.00 E8911CG Manual Cryogen Compressor Water Bypass

GE MR Heat Exchanger Manual Cryogen Compressor Water Bypass Option

Add a level of magnet protection with a Manual Cryogen Compressor Bypass. In case of a power failure, you can cycle municipal or facility water through the cryogen compressor and reduce cryogen loss and reduce the likelihood of quenching.

FEATURES AND BENEFITS

- Easy to install and simple to use
- Helps switch over water supply to your cryogen compressor in the event of loss of power to reduce cryogen loss
- Includes fluid supply pressure gauge, temperature gauge and flow rate meter for easy verification of operation
- Manual operation reduces unintentional switch-overs and coolant dumping during brown-outs and supply power glitches

COMPATIBILITY

Must be used with a GE MR Heat Exchanger:

- E8911CA
- E8911CB
- E8911CC
- E8911CD
- E8912CA
- E8912CB
- E8912CC
- E8912CD NOTE: Item is NON-RETURNABLE and NON-REFUNDABLE

Line	Qty.	Catalog	
	1.00	E8911CJ	Vibration Isolation Spring Kit Option

GE MR Heat Exchanger Vibration Isolation Spring Kit

Mount your GE Heat Exchanger on spring isolators to reduce noise and lessen vibration transmitted to your building

FEATURES AND BENEFITS

- Reduces noise and lessens vibration above or near patient care areas or offices

SPECIFICATIONS

- Custom galvanized dipped for added resistance to corrosive environments elements
- 750 lbs rated capacity each
- 1.12 rated inches deflection
- 670 lb spring constant
- 2.1 max G rating
- Comes in set of 8 (complete kit for a GE MR Heat Exchanger)

COMPATIBILITY

- E8911CA
- E8911CB
- E8911CC
- E8911CD
- E8912CA
- E8912CB
- E8912CC
- E8912CD

Line	Qty.	Catalog	
	1.00	E4504FP	Eaton Single Phase 700 VA Partial UPS (MR package)

Using an uninterruptible power supply (UPS) can help improve user productivity and system reliability, as well as reduce service costs and increase system uptime.

Combining reliable double-conversion topology, internal static bypass and an easy-to-ready LCD menu display, the Eaton 9SX UPS provides the highly efficient and reliable power you expect from a 9-series UPS in a convenient tower form factor.

Applications

The Eaton® Single Phase 9SX 700 VA Partial UPS package is designed to support a variety of GE MR imaging systems. When Catalog# E4504FP is used with MR SIGNA™ Voyager, SIGNA Pioneer and SIGNA Premier systems, the configuration requires ordering a specific power cable (catalog# E4504FN).

Maintain productivity, improve reliability

Reliable power for critical systems

The 9SX offers the robust double-conversion, online power protection needed for medical, light industrial, automation and mission critical IT applications. With zero transfer time to battery, continuous filtering of power, and an internal, automatic static bypass, the 9SX ensures performance and compatibility.

- * Maintains system's host computer and operator's workstation power for ~8 minutes after loss of power
- * Minimizes loss of data
- * Provides clean constant voltage power
- * Host computer and operator's workstation electronics unaffected by under voltage, brownouts, line sags, over voltage, transients, periodic emergency generator testing or automatic transfer switch operation
- * Host computer and operator's workstation electronics protected from utility power factor capacitor switching spikes and ring waves
- * Host computer and operator's workstation electronics protected from utility re-closer operations common during thunderstorms
- * Regulates output voltage to meet and exceed system electronics requirements
- * Allows time for an orderly system shutdown in the event of an extended power outage
- * Reduces maintenance costs
- * Helps increase system uptime
- * Suitable for engine generator applications
- * Suitable for mobile applications (other optional equipment may be needed)
- * Installation of the UPS by GE
- * 1-year warranty on parts and labor

Increased battery life

- * Advanced battery management to extend battery life and provide advanced notice before batteries fail
- * Batteries are hot-swappable

More control

- * Automate power delivery by utilizing switchable, programmable outlets
- * Programmable signal input through the RPO port also enables the UPS to change operating modes in reaction to external events

Advanced LCD interface

- * Simplify UPS monitoring with Eaton's advanced LCD display
- * Easy access to UPS alarm history, energy logs, unit serial numbers and firmware versions enable first time issue resolution right at the source
- * Eight user-selectable languages ensure success for global deployments

Specifications

- * Power: 700 VA / 630 W
- * Input connection: 5-15P, eight feet long
- * Output receptacles: (5) 5-15R
- * Dimensions (H x W x D, in. / mm): 9.9 x 6.3 x 13.9 / 252 x 160 x 357
- * Weight (lb. / kg): 26.5 / 11.5

General

- * Topology: Double-conversion, online
- * Configuration: Tower
- * Color: Black and silver
- * Diagnostics: Full system self-test at power up, ABM battery test every 30 days
- * Warranty: 1 year on electronics and battery
- * Remote power off: Remote On/Off (ROO) and Remote Power Off (RPO) rear terminal blocks

* Contents: UPS, Safety guide, Quick Start Guide, Reference Guide, RS-232 serial cable, USB cable

Electrical input

- * Nominal voltage: 120V default (100/110/120/125V)
- * Input voltage range: Full load: 100-138V, ?25% load: 60-144V
- * Frequency: 50/60 Hz
- * Frequency range: 60 Hz: 50-70 Hz, 50 Hz: 40-60 Hz
- * Input power factor ?.99
- * Input current distortion ?8%

Electrical output

- * Power rating: 700VA / 630W
- * Circuit breaker: None
- * Nominal voltage: 120V default (100/110/120/125V)
- * Output voltage regulation, steady state: $\pm 2\%$ nominal mode
- * Output voltage THD (online): Linear: <3%
- * Power factor: 0.9
- * Efficiency (online mode with resistive load): 87%
- * Transfer time: 0 ms

Communications

- * User interface: Graphical display. UPS status in a single view.
- * LEDs: 4 status-indicating LEDs
- * Communication ports: RS-232 (RJ45) ports; USB port as standard (HID). 6-foot RS-232 and USB cables included

Environment & standards

- * Operating temperature: 0 to 40 °C (32 to 104 °F) in Online mode, with linear derating for altitude
- * Storage temperature: 0 to 35 °C (32 to 95 °F); without batteries: -25 to 55 °C (-13 to 131 °F)
- * Relative humidity: 0 to 96% non-condensing
- * Altitude operating temperature range: UP to 3,000 meters (9,843 ft) above sea level, no derating for 35 °C (95 °F) room temperature
- * Audible noise: < 50 dBA at 1 meter typical
- * RoHS compliance: Yes
- * Safety conformance: UL 1778; IEC 62040-1
- * EMC: FCC Part 15 Class B; IEC 62040-2 C1 & C2
- * Markings: CE; cULus; NOM
- * Battery backup time: 5.8 min@ 630 W, 14 min@ 300W Notes:
 - Customer is responsible for rigging UPS unit
 - Item is non-returnable and non-refundable
 - Removal/disposal of the old unit is the customer's responsibility

Line	Qty.	Catalog	
	1.00	E88221XE	Medrad MRXperion injector on pedestal mount with penetration panel filter kit

The Medrad® MRXperion™ MR Injection System is a smart performer in the MR suite, delivering contrast fluid and data management.

Streamlined Injection Workflow

- Less time preparing for the injection and more time to focus on the patient and optimize procedure management.

Convenience at Point of Care

- On-board eGFR and Weight Based Dosing
- Calculators, an Injection Pressure Graph,
- Independent Test Inject and KVO functions.

Real-time Support

- Connect to VirtualCare® Remote Support* for
- advanced injector system diagnostics, seamless

Improved Efficiencies

- Snap-on/Twist-off Syringe Design
- Auto plunger advance and retract when attaching and detaching syringes
- Automatic filling and priming
- Injection/post-injection reminders

- Injection pressure graph

Reproducible Quality

- Proven track record of design and performance
- On-site field service and VirtualCare® Remote Support* for advanced injection system diagnostics and real-time support

Personalized Care

- Patient-Centric workflow design
- Protocol storage/retrieval
- On-board eGFR and Weight Based Dosing Calculators
- Injection enabled when head is tilted down

The MRXperion™ Injector package with penetration panel filter kit includes:

- Dual injector head on pedestal with integral double hook IV pole
- Scan room unit power supply with 40 ft. (12 m) DC cable
- Scan room fiber optic cable – 40 ft. (12 m)
- Control room fiber optic cable - 150 ft. (45 m)
- Fiber optic quick disconnect panel
- Fiber optic penetration panel kit
- Control room unit (display and pod) with hand-switch
- Display and pod power supplies
- CAT5 cable (display to pod) - 1 ft. (0.3m)
- CAT5 cable (pod to hospital network) - 25 ft. (7.6m)
- Power cords - North America and Japan (3 each), 10 ft. (3 m)
- Power cords – International (3 each), 10 ft. (3 m)
- Operators manual (English)
- Multi-lingual Operators manual CD
- Quick guides (English) for injector and hanger
- Installation manual (English)
- Service manual and schematics manual CDs (English)
- Warranty packet
- Installation, customer's operational training at time of installation, and one year full on-site warranty in Bayer service countries
- LAN port for VirtualCare Remote Service
- Penetration panel filter kit: filter assembly, mounting/centering ring, mounting screws, conductive O-ring (pre-installed on the filter), power supply cable - 10 ft. (3 m), installation instructions

The penetration panel filter kit is intended to be used for an alternate installation of the power supply of the MEDRAD® MRXperion™ Injection System outside of a MR scan room.

System Specifications

System Capabilities

Syringe Capacities:

- Syringe A: 65ml
- Syringe B: 115ml
- Programmable volume range (ml):
 - Syringe A: 0.5 ml to max syringe volume in 0.1 ml increments from 0.5 ml to 31 ml, 1ml increments above 31 ml
 - Syringe B: 1 ml to max syringe volume in 1 ml increments
- Programmable flow rate range (ml/sec)
 - 0.01 to 10 ml/s in 0.01 ml/s increments between 0.01 and 3.1 ml/s
 - 0.1 ml/s increments between 3.1 and 10 ml/s
- KVO (Keep Vein Open): 6 factory presets of 0.25 ml every 15, 20, 30, 45, 60 or 75 sec
- Test Inject: configurable from 0.5 ml to 20 ml in 0.1 ml increments
- Pressure range (psi): 6 factory presets from 100 to 325 PSI (690 to 2240 kPa)
- Injection / Post Injection Reminders: up to 5 settings of 1 sec to 20 minutes in 1 sec increments
- Injection protocol storage: 60 protocols up to 6 phases each
- Injection Hold / Pause: up to 20 minutes in 1 sec increments
- eGFR Calculator
 - For adults: MDRD, Cockcroft-Gault, Modified Cockcroft-Gault and CKD-EPI methods
 - For children: Bedside Schwartz method
- Weight Based Dosing Calculator: user Configurable
- Remote Service Capability: with optional VirtualCare Remote Support

Dimensions and Weight

Control Room Unit

- 15.58" (39.58 cm) W
- 12.71" (32.28 cm) H
- 10.23" (25.98 cm) D
- 17.6 lbs (8.0 kg)
- Scan Room Unit
- 23.30" (59.0 cm) W
- 71.40" (181.0 cm) H
- 23.30" (59.0 cm) D
- 95.7 lbs (43.4 kg)
- Power Supply

- 7.60" (19.0 cm) W
- 3.40" (9.0 cm) H
- 15.40" (39.0 cm) D
- 5 lbs (2.3 kg)

Electrical

- Voltage Requirements
- 100-240 VAC
- 50/60 Hz
- 120VA - 210VA

Line	Qty.	Catalog	
	1.00	E4505SD	200 Amp (166kVA) ProDySC Dynamic Sag Corrector (includes installation)

The ProDySC Dynamic Sag Corrector guards against voltage sags at the system level of your facility without the energy costs and battery care required for other systems. The ProDySC can protect sensitive equipment from the common day-to-day power disturbances (voltage sags) that can cause image degradation, data loss, trips or even equipment damage. Offering includes commissioning, start-up, and installation support (as described below).

FEATURES AND BENEFITS

- Guards against voltage sags at the system, department for facility level
- DySC is optimized for fast sag detection and response time (voltage time of 1.5 ms)
- A green power solution...at > 99% energy efficiency, the DySC has no batteries and over time can offer lower cost of maintenance
- Smaller footprint and lighter weight than comparable (kVA) UPS systems
- Service Contracts offered by GE Healthcare

COMMISSIONING, START-UP, AND INSTALLATION SUPPORT - SCOPE OF WORK

Customer Responsibility:

- Provide space in Imaging Equipment Room for for DySC
- Provide access to electrical panels for imaging equipment to disconnect power and install devices
- Scheduled downtime on imaging equipment to make connections and test DySC
- Acquire Building Permits (if they are required by local codes)
- Hire a Rigger (if needed for placing equipment)
- Accept delivery of DySC hardware

GE Responsibility:

- Coordinate DySC and bypass switch delivery with hospital
- Coordinate with Rigger for hardware placement (if necessary)
- Disconnect and reconnect equipment main power into bypass and DySC and connect DySC output into equipment main disconnect
- Start-up and commissioning of the DySC
- Testing of the DySC and imaging equipment together Conditions:
- Installation will take place at a pre-scheduled time of the customers convenience. Delays outside the control of the installer may result in additional charges
- DySC must be installed in Imaging Equipment room within ~ 10 feet of the (A1) disconnect panel

- Any additional interrupting devices or switches as required by local codes are the responsibility of the hospital
- Alterations to room, doors, floor, and structure; adding capacity to electrical system, or devices to comply with local building codes are outside scope of this agreement

NOTES:

- Item is NON-RETURNABLE and NON-REFUNDABLE

Total Quote Net Selling Price: **\$1,754,072.50**

GPO Agreement Reference Information

Customer:	Rutland Regional Medical Center
Contract Number:	Novation Vizient Supply LLC
Billing Terms:	80% delivery / 20% Installation
Payment Terms:	NET 30
Shipping Terms	FOB DESTINATION

Offer subject to the Terms and Conditions of the applicable Group Purchasing Agreements currently in effect between GE Healthcare and Novation Vizient Supply LLC

If applicable, for more information on this devices' operating system, please visit GE Healthcare's product security portal at: <https://securityupdate.gehealthcare.com/en/products>

This product offering is made per the terms and conditions of Vizient /GE Healthcare GPO Agreements as follows:

Imaging:

XR0391-MR, XR0702-Card./Vasc., XR0673-CT, XR0342-Mammo, XR0351-PET-CT, XR0362-Nuc Med, XR0380-R&F/RAD & XR0592-ICAR-EP/HEMO

Ultrasound:

XR0431-Ultrasound

Vizient: Please login to the Vizient Marketplace Website. If you require assistance or are experiencing issues, please contact Vizient for support:
Email: Connect@VizientInc.com and Phone: 866-600-0618.



Rutland Regional Medical Center
 160 Allen St
 Rutland, VT 05701-4560

This Agreement (as defined below) is by and between the Customer and the GE Healthcare business (“GE Healthcare”), each as identified below for the sale and purchase of the Products and/or Services identified in this Quotation, together with any applicable schedules referred to herein (“Quotation”). “Agreement” is this Quotation and either: (i) the Governing Agreement identified below; or (ii) if no Governing Agreement is identified, the GE Healthcare Terms and Conditions and Warranties that apply to the Products and/or Services identified in this Quotation. In the event of conflict, the Quotation supersedes.

GE Healthcare can withdraw this Quotation at any time before Customer: (i) signs and returns this Quotation or (ii) provides evidence of Quotation acceptance satisfactory to GE Healthcare (“Quotation Acceptance”). On Quotation Acceptance, this Agreement is the complete and final agreement of the parties relating to the Products and/or Services identified in this Quotation. There is no reliance on any terms other than those expressly stated or incorporated by reference in this Agreement and, except as permitted in this Agreement, no attempt to modify will be binding unless agreed to in writing by the parties. Modifications may result in additional fees and cannot be made without GE Healthcare’s prior written consent.

Handwritten or electronic modifications on this Agreement (except an indication of the form of payment, Customer purchase order number and signatures on the signature blocks below) are void.

Governing Agreement:	Novation Vizient Supply LLC
Terms of Delivery	FOB Destination
Billing Terms	80% delivery / 20% Installation
Payment Terms	NET 30
Total Quote Net Selling Price	\$30,000.00
Sales and Use Tax Exemption	Certificate on File

IMPORTANT CUSTOMER ACTIONS:

Please select your planned source of funds. Source of funds is assumed to be cash unless you choose another option. Once equipment has been shipped, source of funds changes cannot be allowed.

- Cash
- GE HFS Loan GE HFS Lease
- Other Financing Loan Other Financing Lease Provide Finance Company Name _____

The parties have caused this Agreement to be executed by their authorized representative as of the last signature date below.

Rutland Regional Medical Center

Signature: _____

Print Name: _____

Title: _____

Date: _____

Purchase Order Number, if applicable

GE Precision Healthcare LLC, a GE Healthcare business

Signature: Edwina Ashe

Title: Imaging Account Manager

Date: June 15, 2021

To Accept This Quotation

Please sign and return this quotation together with your Purchase Order to:

Name: Edwina Ashe

Email edwina.ashe@ge.com

Phone: (351) 209-0771

Fax:

Payment Instructions

Please **remit** payment for invoices associated with this quotation to:

GE Precision Healthcare LLC

P.O. Box 96483

Chicago, IL 60693

FEIN: 83-0849145

Rutland Regional Medical Center**Addresses:**

Bill To: RUTLAND REGIONAL MEDICAL CENTER

RUTLAND REGIONAL MEDICAL, CENTER 160 ALLEN ST
RUTLAND, VT, 05701-4560

Ship To: RUTLAND REGIONAL MEDICAL CENTER

CENTER 160 ALLEN ST RUTLAND, VT, 05701-4560

To Accept This Quotation

- Please sign the quote and any included attachments (where requested).
- If requested, please indicate your form of payment.
- If you include a purchase order, please make sure it references the following information:
The correct Quote number and Version number above
The correct Remit To information as indicated in **“Payment Instructions”** above
Your correct SHIP TO and BILL TO site name and address
The correct Total Price as indicated above

Upon submission of a purchase order in response to this quotation, GE Healthcare requests the following to evidence agreement to contract terms: Signature page on quote filled out with signature and P.O. number **** OR**** Verbiage on the purchase order must state one of the following:

(i) Per the terms of Quotation # _____, (ii) Per the terms of GPO # _____; (iii) Per the terms of MPA# _____; or (iv) Per the terms of SAA # _____.

Include applicable quote/agreement number with the reference on the purchase order. In addition, Source of Funds (choice of Cash/Third Party Load or GE HFS Lease Loan or Third Party Lease through _____), must be indicated, which may be done on the Quote Signature Page (for signed quotes), or the Purchase Order (where quotes are not signed) or via a separate written source of funds statement (if provided by GE Healthcare).”

Catalog Item Details

Line	Qty.	Catalog	
	1.00	NI_MR_INSTALLATION	\$30,000 is applied to 3rd-Party Rigging Services, as directed by Customer. Rigging (including excess/additional rigging costs) remains the Customer's responsibility. Unapplied rigging funds will be forfeited without refund or credit.

Total Quote Net Selling Price: **\$30,000.00**

GPO Agreement Reference Information

Customer:	Rutland Regional Medical Center
Contract Number:	Novation Vizient Supply LLC
Billing Terms:	80% delivery / 20% Installation
Payment Terms:	NET 30
Shipping Terms	FOB DESTINATION

Offer subject to the Terms and Conditions of the applicable Group Purchasing Agreements currently in effect between GE Healthcare and Novation Vizient Supply LLC

If applicable, for more information on this devices' operating system, please visit GE Healthcare's product security portal at: <https://securityupdate.gehealthcare.com/en/products>

This product offering is made per the terms and conditions of Vizient /GE Healthcare GPO Agreements as follows:

Imaging:

XR0391-MR, XR0702-Card./Vasc., XR0673-CT, XR0342-Mammo, XR0351-PET-CT, XR0362-Nuc Med, XR0380-R&F/RAD & XR0592-ICAR-EP/HEMO

Ultrasound:

XR0431-Ultrasound

Vizient: Please login to the Vizient Marketplace Website. If you require assistance or are experiencing issues, please contact Vizient for support:
Email: Connect@VizientInc.com and Phone: 866-600-0618.



Rutland Regional Medical Center
 160 Allen St
 Rutland, VT 05701-4560

This Agreement (as defined below) is by and between the Customer and the GE Healthcare business (“GE Healthcare”), each as identified below for the sale and purchase of the Products and/or Services identified in this Quotation, together with any applicable schedules referred to herein (“Quotation”). “Agreement” is this Quotation and either: (i) the Governing Agreement identified below; or (ii) if no Governing Agreement is identified, the GE Healthcare Terms and Conditions and Warranties that apply to the Products and/or Services identified in this Quotation. In the event of conflict, the Quotation supersedes.

GE Healthcare can withdraw this Quotation at any time before Customer: (i) signs and returns this Quotation or (ii) provides evidence of Quotation acceptance satisfactory to GE Healthcare (“Quotation Acceptance”). On Quotation Acceptance, this Agreement is the complete and final agreement of the parties relating to the Products and/or Services identified in this Quotation. There is no reliance on any terms other than those expressly stated or incorporated by reference in this Agreement and, except as permitted in this Agreement, no attempt to modify will be binding unless agreed to in writing by the parties. Modifications may result in additional fees and cannot be made without GE Healthcare’s prior written consent.

Handwritten or electronic modifications on this Agreement (except an indication of the form of payment, Customer purchase order number and signatures on the signature blocks below) are void.

Governing Agreement:	Novation Vizient Supply LLC
Terms of Delivery	FOB Destination
Billing Terms	80% delivery / 20% Installation
Payment Terms	NET 30
Total Quote Net Selling Price	\$5,000.00
Sales and Use Tax Exemption	Certificate on File

IMPORTANT CUSTOMER ACTIONS:

Please select your planned source of funds. Source of funds is assumed to be cash unless you choose another option. Once equipment has been shipped, source of funds changes cannot be allowed.

- Cash
- GE HFS Loan GE HFS Lease
- Other Financing Loan Other Financing Lease Provide Finance Company Name _____

The parties have caused this Agreement to be executed by their authorized representative as of the last signature date below.

Rutland Regional Medical Center

Signature: _____

Print Name: _____

Title: _____

Date: _____

Purchase Order Number, if applicable

GE Precision Healthcare LLC, a GE Healthcare business

Signature: Edwina Ashe

Title: Imaging Account Manager

Date: June 15, 2021

To Accept This Quotation

Please sign and return this quotation together with your Purchase Order to:

Name: Edwina Ashe
Email edwina.ashe@ge.com
Phone: (351) 209-0771
Fax:

Payment Instructions

Please **remit** payment for invoices associated with this quotation to:

GE Precision Healthcare LLC
P.O. Box 96483
Chicago, IL 60693

FEIN: 83-0849145

Rutland Regional Medical Center**Addresses:**

Bill To: RUTLAND REGIONAL MEDICAL CENTER

RUTLAND REGIONAL MEDICAL, CENTER 160 ALLEN ST
RUTLAND, VT, 05701-4560

Ship To: RUTLAND REGIONAL MEDICAL CENTER

CENTER 160 ALLEN ST RUTLAND, VT, 05701-4560

To Accept This Quotation

- Please sign the quote and any included attachments (where requested).
- If requested, please indicate your form of payment.
- If you include a purchase order, please make sure it references the following information:
The correct Quote number and Version number above
The correct Remit To information as indicated in **“Payment Instructions”** above
Your correct SHIP TO and BILL TO site name and address
The correct Total Price as indicated above

Upon submission of a purchase order in response to this quotation, GE Healthcare requests the following to evidence agreement to contract terms: Signature page on quote filled out with signature and P.O. number **** OR**** Verbiage on the purchase order must state one of the following:

(i) Per the terms of Quotation # _____, (ii) Per the terms of GPO # _____; (iii) Per the terms of MPA# _____; or (iv) Per the terms of SAA # _____.

Include applicable quote/agreement number with the reference on the purchase order. In addition, Source of Funds (choice of Cash/Third Party Load or GE HFS Lease Loan or Third Party Lease through _____), must be indicated, which may be done on the Quote Signature Page (for signed quotes), or the Purchase Order (where quotes are not signed) or via a separate written source of funds statement (if provided by GE Healthcare).”

Catalog Item Details

Line	Qty.	Catalog	
	1.00	E8812CL	MR CCTV System (2 camera kit) with 17 inch LCD Monitor

This MRI closed-circuit TV camera package allows for visual monitoring of your patients during their scans. Ceiling- or wall-mounted fixed camera is unobtrusive and transmits high-quality color images in real time to the operator's console where a 17" TFT LCD monitor is located. A dual camera system allows split-screen viewing by the technologists to see both the front and back sides of the magnet simultaneously. Tested and approved by GE on a 3-Tesla magnet (camera and mount).

Includes:

- 17" TFT LCD color monitor
- (2) Compact color cameras with lens
- (2) Signal interface box
- (2) Exterior-mount power supply
- (2) Mounting brackets for camera
- (2) sets of cables: 10', 40', 100'
- MRI-conditional to 3-Tesla when installed by manufacturers' directions

Total Quote Net Selling Price: \$5,000.00

GPO Agreement Reference Information

Customer:	Rutland Regional Medical Center
Contract Number:	Novation Vizient Supply LLC
Billing Terms:	80% delivery / 20% Installation
Payment Terms:	NET 30
Shipping Terms	FOB DESTINATION

Offer subject to the Terms and Conditions of the applicable Group Purchasing Agreements currently in effect between GE Healthcare and Novation Vizient Supply LLC

If applicable, for more information on this devices' operating system, please visit GE Healthcare's product security portal at: <https://securityupdate.gehealthcare.com/en/products>

This product offering is made per the terms and conditions of Vizient /GE Healthcare GPO Agreements as follows:

Imaging:

XR0391-MR, XR0702-Card./Vasc., XR0673-CT, XR0342-Mammo, XR0351-PET-CT, XR0362-Nuc Med, XR0380-R&F/RAD & XR0592-ICAR-EP/HEMO

Ultrasound:

XR0431-Ultrasound

Vizient: Please login to the Vizient Marketplace Website. If you require assistance or are experiencing issues, please contact Vizient for support:
Email: Connect@VizientInc.com and Phone: 866-600-0618.



Formal Quotation

Document number: 2301185394
Date of issue: 07/02/2021

Sold to (94037337):
RUTLAND REGIONAL MEDICAL CENTER
160 Allen St
RUTLAND VT 05701-4595
UNITED STATES

Last updated: 07/02/2021 13:56:54
Expiration date: 09/02/2021

Our federal tax ID #: 133429115

Our contact details
Account Manager: Open Hartford

Incoterms: FOB DESTINATION
Payment terms: Within 30 Days Due Net

Item	Product and Description	Quantity	UoM	Price/Unit	Amount
Terms and conditions of Vizient Supply Llc contract XR0610 prevail.					
10	866185 Expression Patient Monitor (MR400)	1	PCE		
	A01 Standard Accessories	1	PCE	0.00/1 PCE	0.00
	F01 Basic(NBP,ECG,SpO2,CO2,RR)	1	PCE	76,400.00/1 PCE	76,400.00
				Gross amount	76,400.00/1 PCE
				Agreement disc. (33%)	-25,212.00
				Net amount	51,188.00/1 PCE
	UPC code: 884838039131				
	Agreement number: GPO00001C0				
	Commodity code (HS/HTS): 9018195500				
20	866428 Expression MR400 Accessories	1	PCE		
	F11 Adult F01 Access.	1	PCE	1,187.00/1 PCE	1,187.00
	H01 Power	1	PCE	1,288.00/1 PCE	1,288.00
	H02 Patient Connections	1	PCE	8,004.00/1 PCE	8,004.00
	H03 Pat. Connections - ECG CV	1	PCE	1,600.00/1 PCE	1,600.00
				Gross amount	12,079.00/1 PCE
				Agreement disc. (33%)	-3,986.07
				Net amount	8,092.93/1 PCE
	UPC code: 884838056312				
	Agreement number: GPO00001C0				
	Commodity code (HS/HTS): 9018191000				

Via ACH/EFT:
Payee: Philips Healthcare
Bank: Bank of America
Account#: 3750202223
ABA#: 1110-0001-2

Via Check:
Philips Healthcare
P.O. Box 100355
Atlanta, GA 30384-0355





Formal Quotation

Document number: 2301185394
Date of issue: 07/02/2021

Item	Product and Description	Quantity	UoM	Price/Unit	Amount
					Currency: USD
30	865471	1	PCE	List Price	12,500.00/1 PCE
	Expression Information Portal (IP5)				12,500.00
	A01 Standard Accessories	1	PCE		0.00/1 PCE
	A07 Flex Antenna	1	PCE		1,500.00/1 PCE
				Agreement disc. (33%)	-4,620.00
				Net amount	9,380.00/1 PCE
	UPC code: 884838031890				
	Agreement number: GPO00001C0				
	Commodity code (HS/HTS): 9018195500				
Total net amount					68,660.93

Philips Healthcare is pleased to inform you that financing of its products and services is available to qualified applicants. To obtain more information contact Philips Medical Capital @ 866-513-4PMC.

Contract information for: Vizient Supply Llc (T3 Pm & Mcs)

Prices quoted are subject to and reflect applicable discounts per the terms and conditions of the following contract:
Contract # XR0610 Expiration Sep. 30, 2021

MD Buyline -- Please be aware that MD Buyline utilizes Philips current list prices as the basis of calculation for discount comparisons. If you are a customer utilizing a GPO contract with fixed pricing, it is likely that the list price on this quotation is based on an older published price list, and may be considerably less than the current listpricing that MD Buyline uses in its analysis. As such, the MD Buyline discount recommendation may be higher than the Philips offering for your particular purchase. If you have a question, please ask your Sales Representative for clarification. Should you have concerns or want additional information relative to how discount comparisons are calculated at MD Buyline, please call your analyst at MD Buyline.

All work is scheduled within normal working hours; Monday through Friday, 8 a.m. to 5 p.m. excluding Philips holidays. All pricing is based on travel zones 1-3. For travel zones beyond 1-3, consult your Philips sales rep for alternate pricing. It is the customers responsibility to provide Philips with the access necessary to complete the quoted work in a continuous start to finish manner. Excessive delays and multiple visits will result in additional charges. All prices are based upon 'adequate access' to work areas that are free from obstruction. If it is determined, during the implementation that asbestos removal is required; Philips will suspend performance until the Customer remediates the asbestos. Philips will work with the customers staff to reduce the downtime during the system transition.

Products are for USA end-use only. Taxes, if applicable, are not included unless noted but will be added to the invoice. The Purchase Order must reference the Quote Number and your Purchase Agreement. Please indicate your requested delivery date and your preference, if any, to accept and pay for partial shipments. If this quote includes Value-Added Services, they may be invoiced separately. Additional sold training must be completed within twelve months of delivery/installation. System cabling, if included, is specified at the standard grade unless noted otherwise.

This quote specifically excludes Licensing & Permit Fees, Prevailing Wage Compensation and Union Labor.

IMPORTANT NOTICE: Health care providers are reminded that if the transactions herein include or involve a loan or a discount (including a rebate or other price reduction), they must fully and accurately report such loan or discount on cost reports or other applicable reports or claims for payment

Via ACH/EFT:
Payee: Philips Healthcare
Bank: Bank of America
Account#: 3750202223
ABA#: 1110-0001-2

Via Check:
Philips Healthcare
P.O. Box 100355
Atlanta, GA 30384-0355





Formal Quotation

Document number: 2301185394

Date of issue: 07/02/2021

submitted under any federal or state health care program, including but not limited to Medicare and Medicaid, such as maybe required by state or federal law, including but not limited to 42 CFR1001.952(h).

This quotation is issued pursuant to, and any PO for the items herein will be accepted subject to the Terms of any current Contract with the customer. If there is no contract in place, this quotation is issued pursuant to, and any PO for the items herein will be accepted subjected to Philips Terms and Conditions of sale posted at <http://www.usa.philips.com/healthcare/about/terms-conditions> and the terms herein.

This quotation contains confidential and proprietary information of Philips Healthcare and is intended for use only by the customer whose name appears on this quotation. It may not be disclosed to third parties without prior written consent of Philips Healthcare.

Save time and effort on your next order.

Try online ordering!

The Philips Healthcare Store has many of the consumables and supplies you order as a healthcare professional. Check out the store today; it's easy to register!

<http://www.patientcare.shop.philips.com/>

Please send purchase orders via email, fax or mail to:

Email: Healthcare.Orders@philips.com

Fax: 1-800-947-3299

Philips Healthcare

A division of Philips North America LLC

414 Union St, 2nd Floor

Nashville, TN 37219

Via ACH/EFT:
Payee: Philips Healthcare
Bank: Bank of America
Account#: 3750202223
ABA#: 1110-0001-2

Via Check:
Philips Healthcare
P.O. Box 100355
Atlanta, GA 30384-0355



1025 Willa Springs Drive
Winter Springs, FL 32708 U.S.A.

PHONE: 407-677-8022
FAX: 407-677-5037

Sales Quote 155995

CONTACT NAME SHARI PATCH		QUOTE DATE 6/11/2021	REVISION DATE 6/11/2021
CONTACT EMAIL spatch@rrmc.org		SALES MANAGER Bobby Sanborn	CSR JLV
CONTACT PHONE 802-747-1707		SALES MANAGER EMAILbsanborn@iradimed.com	REGION BOS
		SALES MANAGER PHONE (781) 760 0791	TAX CODE
CUSTOMER P.O. QUOTE	CONFIRMED TO SHARI PATCH	TERMS Net 45 Days	SHIP VIA UPS Ground
		FOB Destination - EXW	FREIGHT TERMS Ppd & Add

**S
O
L
D

T
O**

1030073Q
RUTLAND REGIONAL MEDICAL CTR
160 ALLEN STREET
RUTLAND, VT 05701-4595
US
PHONE: 802-775-7111

**S
H
I
P

T
O**

1030073Q
RUTLAND REGIONAL MEDICAL CTR
160 ALLEN STREET
RUTLAND, VT 05701-4595
US
PHONE: 802-775-7111

**B
I
L
L

T
O**

1030073Q
RUTLAND REGIONAL MEDICAL CTR
160 ALLEN STREET
RUTLAND, VT 05701-4595
US
PHONE: 802-775-7111

LINE	PART ID	DESCRIPTION	ORDER QTY	U/M	PRICE CODE	UNIT PRICE	EXTENDED PRICE
------	---------	-------------	-----------	-----	------------	------------	----------------

Modified MRI IV Pump Package

1	3860+	MRIDIUM MR INFUSION PUMP W/ SPO2	1	EA	VZ2	19,436.00	19,436.00
2	3861	MRIDIUM 3861 SIDECAR SECOND CHANNEL	1	EA	VZ2	9,051.00	9,051.00
3	3865	MRIDIUM 3865 REMOTE MONITOR	1	EA	VZ2	6,479.00	6,479.00
4	1119	ROLL STAND, NON-MAGNETIC	1	EA	VZ2	853.00	853.00
5	1145	MRIDIUM 3860 DERS LIBRARY KIT	1	EA	VZ2	2,287.00	2,287.00
6	9992	MRIDIUM DERS INITIAL LIBRARY ENTRY	1	EA	VZ2	1,191.00	1,191.00
7	9999	TWO (2) DAY APPLICATIONS TRAINING	1	EA	VZ2	2,668.00	2,668.00
8	9593P	MRIDIUM PREMIUM MAINTENANCE 3 YR	1	EA	VZ2	4,575.00	4,575.00
9	9693P	SIDECAR PREMIUM MAINTENANCE 3 YR	1	EA	VZ2	2,910.00	2,910.00
10	9793P	REMOTE PREMIUM MAINTENANCE 3 YR	1	EA	VZ2	2,530.00	2,530.00

PRICING REFLECTS TIER 2 VIZIENT CONTRACT DISCOUNT. VIZIENT CONTRACT# IV0010 / VIZIENT CONTRACT TERMS AND CONDITIONS APPLY TO THIS PURCHASE

***** QUOTATION VALID FOR A SHIPPABLE PURCHASE ORDER RECEIVED ON OR BEFORE 07/09/21 *****

ALL APPLICABLE TAXES WILL BE IN ADDITION TO THE AMOUNT LISTED BELOW UNLESS A TAX EXEMPT FORM IS PROVIDED BY THE HOSPITAL

INSERVICE TRAINING MUST BE COMPLETED WITHIN 90 DAYS OF PRODUCT SHIPMENT
DERS MUST BE COMPLETED WITHIN 90 DAYS OF PRODUCT SHIPMENT

ORDER TOTAL:	\$51,980.00
---------------------	--------------------



Rutland Regional Medical Center
 160 Allen St
 Rutland, VT 05701-4560

This Agreement (as defined below) is by and between the Customer and the GE Healthcare business (“GE Healthcare”), each as identified below for the sale and purchase of the Products and/or Services identified in this Quotation, together with any applicable schedules referred to herein (“Quotation”). “Agreement” is this Quotation and either: (i) the Governing Agreement identified below; or (ii) if no Governing Agreement is identified, the GE Healthcare Terms and Conditions and Warranties that apply to the Products and/or Services identified in this Quotation. In the event of conflict, the Quotation supersedes.

GE Healthcare can withdraw this Quotation at any time before Customer: (i) signs and returns this Quotation or (ii) provides evidence of Quotation acceptance satisfactory to GE Healthcare (“Quotation Acceptance”). On Quotation Acceptance, this Agreement is the complete and final agreement of the parties relating to the Products and/or Services identified in this Quotation. There is no reliance on any terms other than those expressly stated or incorporated by reference in this Agreement and, except as permitted in this Agreement, no attempt to modify will be binding unless agreed to in writing by the parties. Modifications may result in additional fees and cannot be made without GE Healthcare’s prior written consent.

Handwritten or electronic modifications on this Agreement (except an indication of the form of payment, Customer purchase order number and signatures on the signature blocks below) are void.

Governing Agreement:	GEHC Standard Terms Apply
Terms of Delivery	FOB Destination
Billing Terms	100% billing at Ship Completion (Fulfillment) / Delivery
Payment Terms	Due On Receipt-30 Days
Total Quote Net Selling Price	\$-60,000.00
Sales and Use Tax Exemption	Certificate on File

IMPORTANT CUSTOMER ACTIONS:

Please select your planned source of funds. Source of funds is assumed to be cash unless you choose another option. Once equipment has been shipped, source of funds changes cannot be allowed.

- Cash
- GE HFS Loan GE HFS Lease
- Other Financing Loan Other Financing Lease Provide Finance Company Name _____

The parties have caused this Agreement to be executed by their authorized representative as of the last signature date below.

Rutland Regional Medical Center

Signature: _____

Print Name: _____

Title: _____

Date: _____

Purchase Order Number, if applicable

GE Precision Healthcare LLC, a GE Healthcare business

Signature: Edwina Ashe

Title: Imaging Account Manager

Date: June 21, 2021

To Accept This Quotation

Please sign and return this quotation together with your Purchase Order to:

Name: Edwina Ashe
Email edwina.ashe@ge.com
Phone: (351) 209-0771
Fax:

Payment Instructions

Please **remit** payment for invoices associated with this quotation to:

GE Precision Healthcare LLC
P.O. Box 96483
Chicago, IL 60693

FEIN: 83-0849145

Rutland Regional Medical Center**Addresses:**

Bill To: RUTLAND REGIONAL MEDICAL CENTER

RUTLAND REGIONAL MEDICAL, CENTER 160 ALLEN ST
RUTLAND, VT, 05701-4560

Ship To: RUTLAND REGIONAL MEDICAL CENTER

CENTER 160 ALLEN ST RUTLAND, VT, 05701-4560

To Accept This Quotation

- Please sign the quote and any included attachments (where requested).
- If requested, please indicate your form of payment.
- If you include a purchase order, please make sure it references the following information:
The correct Quote number and Version number above
The correct Remit To information as indicated in **“Payment Instructions”** above
Your correct SHIP TO and BILL TO site name and address
The correct Total Price as indicated above

Upon submission of a purchase order in response to this quotation, GE Healthcare requests the following to evidence agreement to contract terms: Signature page on quote filled out with signature and P.O. number **** OR**** Verbiage on the purchase order must state one of the following:

(i) Per the terms of Quotation # _____, (ii) Per the terms of GPO # _____; (iii) Per the terms of MPA# _____; or (iv) Per the terms of SAA # _____.

Include applicable quote/agreement number with the reference on the purchase order. In addition, Source of Funds (choice of Cash/Third Party Load or GE HFS Lease Loan or Third Party Lease through _____), must be indicated, which may be done on the Quote Signature Page (for signed quotes), or the Purchase Order (where quotes are not signed) or via a separate written source of funds statement (if provided by GE Healthcare).”

Catalog Item Details

Qty.	Credits and Adjustments	
1.00	1.5T SIGNA HDx Trade-in	\$-60,000.00
<i>Total Quote Net Selling Price:</i>		<i>\$-60,000.00</i>

If applicable, for more information on this devices' operating system, please visit GE Healthcare's product security portal at: <https://securityupdate.gehealthcare.com/en/products>

Trade-in Addendum to GE Healthcare Quotation

This Trade-In Addendum (“Addendum”), effective on **June 21, 2021**, between the GE Healthcare business identified on the Quotation and **Rutland Regional Medical Center** (“Customer”), is made a part of Quotation # **2005700941.43** ^ dated **June 21, 2021** (“Quotation”) and modifies it as follows:

A. Customer: (i) certifies that it has full legal title to the equipment and/or mobile vehicle (“mobile vehicles” are defined as any systems requiring a vehicle title) listed in Section E (“Trade-In Equipment”), free and clear of all liens and encumbrances; (ii) conveys title and, if applicable, registration and license documents to GE Healthcare effective on the date of removal or receipt of the Trade-In Equipment (mobile vehicles will not be removed from Customer site until GE Healthcare has received a clean title signed over to GE Healthcare); and (iii) affirms that the Trade-In Equipment has never been used on or to provide care to animals. If GE Healthcare removes the Trade-In Equipment, it will do so at its expense at a mutually agreed time. Trade-In Equipment shall be removed no later than thirty days following installation of Customer’s new system, unless explicitly otherwise agreed to by the parties in writing.

Mobile vehicles must include the VIN# on this trade-in addendum: VIN# [insert Vin #]. Mobile vehicles must have a valid DOT sticker and be road worthy at the time GE Healthcare is to take possession of them in order for GE Healthcare to accept a mobile vehicle on trade-in. Any and all logos or hospital affiliation stickers must be removed (outside and inside) by Customer and Customer shall clean the mobile vehicle of all debris and medical supplies prior to removal of the mobile vehicle by GE Healthcare.

B. Customer is responsible for: (i) providing timely, unrestricted access to the Trade-In Equipment in a manner that affords GE Healthcare, or third-party purchaser of the Equipment through GE Healthcare, the ability to complete Equipment inspection and testing, and the ability to complete an operating system back-up prior to de-installation within the timeframe required by GE Healthcare or said third-party purchaser, failure of which to provide may result in termination of this Trade-in Addendum and related credits and/or payments; (ii) ensuring that the Trade-In Equipment and the site where it is located are clean and free of bodily fluids; (iii) informing GE Healthcare of site-related safety risks; (iv) properly managing, transporting and disposing of hazardous materials located on site in accordance with applicable legal requirements; (v) rigging, construction, demolition or facility reconditioning expenses, unless expressly stated otherwise in the Quotation; and (vi) risk of loss and damage to the Trade-In Equipment until safety risks are remediated and the Trade-In Equipment is removed or returned.

C. Prior to removal or return to GE Healthcare, Customer must: (i) remove all Protected Health Information as such term is defined in 45 C.F.R. § 160.103 (“PHI”) from the Trade-In Equipment; and (ii) indemnify GE Healthcare for any loss resulting from PHI not removed. GE Healthcare has no obligation in connection with PHI not properly removed.

D. GE Healthcare may in its sole discretion reduce the trade-in amount or decline to purchase the Trade-In Equipment and adjust the total purchase price of the Quotation accordingly if: (i) the terms of this Addendum are not met; (ii) Customer fails to provide access to the Trade-In Equipment as required herein; or (ii) the Trade-In Equipment is missing components or is inoperable and/or non-functioning when removed or returned – Customer is required to confirm for GE Healthcare the operability of the Trade-In Equipment prior to the deinstallation of the Equipment. All other terms and conditions of the Quotation remain in full force and effect.

E. Trade-In Equipment:

Trade-In Equipment Mfr.	<u>Model & Description</u>	<u>Quantity</u>	System ID*	Trade-In Amount (\$)
GENERAL ELECTRIC	1.5T SIGNA HDx Trade-in	1.00	802747MR	\$ -60,000.00

This Addendum is executed when: (i) signed by the parties below; (ii) Customer receives this Addendum and signs the Quotation that references the Trade-In Equipment; or (iii) Customer receives this Addendum and issues a purchase order identifying either the terms of the Quotation (which includes a reference to the Trade-In Equipment) or the Governing Agreement identified on the Quotation as governing the order (PO# _____)†.

Rutland Regional Medical Center

GE Healthcare

Signature: _____

Signature: _____

Print Name: _____

Print Name: _____

Title: _____

Title: _____

Date: _____

Date: _____

^ A Quotation number must be provided on this document.

* In the event the Trade-In Equipment does not have a System ID, please record the serial number of each component that comprises the Trade-In Equipment.

† If you are relying upon the purchase order to reflect acceptance of the terms contained herein, please update this document with the applicable PO number upon receipt of the PO. Failure to do so may result in delays surrounding deinstallation of the System(s).

GPO Agreement Reference Information

Customer:	Rutland Regional Medical Center
Contract Number:	
Billing Terms:	100% billing at Ship Completion (Fulfillment) / Delivery
Payment Terms:	Due On Receipt-30 Days
Shipping Terms	FOB DESTINATION

Offer subject to the Terms and Conditions of the applicable Group Purchasing Agreements currently in effect between GE Healthcare and

If applicable, for more information on this devices' operating system, please visit GE Healthcare's product security portal at: <https://securityupdate.gehealthcare.com/en/products>



GE Healthcare Terms & Conditions (Rev 01.30.20)

1. **Definitions.** As identified in this Agreement, "Equipment" is hardware and embedded software that is licensed with the purchase of the hardware delivered to Customer in GE Healthcare's packaging and with its labeling; "Software" is software developed by GE Healthcare and/or delivered to Customer in GE Healthcare's packaging and with its labeling, and Documentation associated with the software; "Third Party Software" and "Third Party Equipment" are respectively software developed by a third party, and hardware and embedded software that is licensed with the purchase of the hardware, that is delivered to Customer in the third party's packaging and with its labeling (collectively, "Third Party Product"); "Product" is Equipment, Software and Third Party Product; and "Services" are Product support or professional services; "Subscription" is a limited-term, non-transferable license to access and use a Product (except Healthcare Digital Products), including any associated support Services; "Healthcare Digital Products" are: (i) Software identified in the Quotation as "Centricity"; (ii) Third Party Software licensed for use in connection with Centricity Software; (iii) hardware used to operate Centricity or Third Party Software; (iv) Services provided for implementation, installation or support and maintenance of Centricity or Third Party Software licensed for use in connection with Centricity Software; and/or (v) any Product or Service that is identified in a Healthcare Digital Quotation. "Specifications" are GE Healthcare's written specifications and manuals as of the date the Equipment shipped. "Documentation" is the online help functions, user instructions and manuals regarding the installation and operation of the Product as made available by GE Healthcare to Customer.

2. **Term and Termination.** Software licenses, Services and/or Subscriptions will have individual term lengths identified in the Quotation. If there is a material breach of this Agreement and/or the Quotation that is not cured by the breaching party within 60 days from receipt of written notice, the non-breaching party can terminate the respective Agreement or Quotation. Other than as set forth in this Agreement, neither party can unilaterally terminate this Agreement or a Quotation. Any remaining undisputed, unpaid fees become immediately due and payable on expiration or termination. Expiration or termination of this Agreement will have no effect on Quotations executed prior to the date of expiration or termination.

3. **Software License.** Other than as identified in a Quotation, GE Healthcare grants Customer a non-exclusive, non-transferable, non-sublicensable, perpetual license to use the Software for Customer's internal business purposes only in the United States consistent with the terms of this Agreement. Customer's independent contractors (except GE Healthcare competitors) may use the Software, but Customer is responsible for their compliance with this license, and additional license fees may apply. Customer cannot modify, reverse engineer, copy or create derivative works of the Software, except for making 1 backup copy, and cannot remove or modify labels or notices of proprietary rights of the Software or Documentation. If GE Healthcare provides Third Party Software, Customer will comply with third party license terms, and licensors are third-party beneficiaries of this Agreement.

4. Commercial Logistics.

4.1. Order Cancellation and Modifications.

4.1.1. Cancellation. If Customer cancels an order prior to shipment without GE Healthcare's written consent, Customer will be responsible for all third-party expenses incurred by GE Healthcare prior to Customer's order cancellation and GE Healthcare may charge: (i) a fee of up to 10% of the Product price; and (ii) for site evaluations performed prior to cancellation. GE Healthcare will retain, as a credit, payments received up to the amount of the cancellation charge. Customer must pay applicable progress payments (other than final payment) prior to final calibration, and GE Healthcare may delay calibration until those payments are received. If Customer does not schedule a delivery date within 6 months after order entry, GE Healthcare may cancel on written notice. This Section does not apply to Software or Subscriptions, Third Party Products and/or related professional or installation services; those orders are non-cancellable.

4.1.2. Used Equipment. Equipment identified as pre-owned, refurbished, remanufactured or demonstration Equipment is not new and may have received reconditioning to meet Specifications ("Used Equipment"). Sale of Used Equipment is subject to availability. If it is no longer available, GE Healthcare will attempt to identify other Used Equipment in its inventory that meets Customer's needs, and if substitute Used Equipment is not acceptable, GE Healthcare will cancel the order and refund any deposit Customer paid for the Used Equipment.

4.2. Site Preparation. Customer is responsible for network and site preparation, including costs, in compliance with GE Healthcare's written requirements and applicable laws. GE Healthcare may refuse to deliver or install if the site has not been properly prepared or there are other impediments.

4.3. Transportation, Title and Risk of Loss. Unless otherwise identified in the Quotation, shipping terms are FOB Destination. Title and risk of loss to Equipment and Third Party Equipment passes to Customer on delivery to Customer's designated delivery location.

4.4. Delivery, Returns and Installation. Delivery dates are approximate. Products may be delivered in installments. GE Healthcare may invoice multiple installment deliveries on a consolidated basis, but this does not release Customer's obligation to pay for each installment delivery. Delivery occurs: (i) for Product, on electronic or physical delivery to Customer; and (ii) for Services, on performance.

Products cannot be returned for refund or credit if they match the Quotation.

Delivery and installations will be performed from 8am to 5pm local time, Monday-Friday, excluding GE Healthcare holidays, and outside those hours for an additional fee. Customer will: (i) install cable and assemble products not provided by GE Healthcare; (ii) enable connectivity and interoperability with products not provided by GE Healthcare; (iii) pay for construction and rigging costs; and (iv) obtain all licenses, permits and approvals for installation, use and disposal of Products. For upgrades and revisions to non-Healthcare Digital Products, Customer must return replaced components to GE Healthcare at no charge.

5.

5.1. Information Technology Professional Services ("ITPS"). ITPS must be completed within 12 months of the later of the ITPS order date or Product delivery. If not done within this time period, other than because of GE Healthcare's failure to perform, ITPS performance obligations expire without refund. ITPS includes project management, HL7/HIS system integration, database conversion, network design and integration and separately cataloged software installations. This Section does not apply to Healthcare Digital Products.

5.2. Acceptance.

5.2.1. Equipment Acceptance. Beginning on completion of installation (not to exceed 30 days from shipment) or delivery (if installation is not required), Customer will have 5 days to determine if the Equipment operates substantially in accordance with Specifications ("Equipment Test Period"). If the Equipment fails to perform accordingly, Customer will provide to GE Healthcare: (i) written notice; (ii) access to the Equipment; and (iii) a reasonable time to bring the Equipment into compliance. After correction by GE Healthcare, Customer will have the remainder of the Equipment Test Period or 3 days, whichever is greater, to continue testing. Equipment is accepted on the earlier of expiration of the Equipment Test Period or the date the Equipment is first used for non-acceptance testing purposes.

5.2.2. Software Acceptance. Beginning on completion of Software implementation, Customer will have 30 days to determine if the Software operates substantially in accordance with the Documentation ("Software Test Period"). If the Software fails to perform accordingly, Customer will provide to GE Healthcare: (i) written notice; (ii) access to the Software; and (iii) a reasonable time to bring the Software into compliance. After correction by GE Healthcare, Customer will have the remainder of the Software Test Period or 5 days, whichever is greater, to continue testing. Software is accepted on the first to occur of: (a) expiration of the Software Test Period; (b) the date Software is first used to process actual data; or (c) the "Go-Live Date" as defined in the Quotation.

5.2.3. Third Party Product Acceptance. Third Party Products are accepted 5 days after delivery.

5.2.4. Subscription Acceptance. Products provided pursuant to a Subscription are accepted 5 days after GE Healthcare provides Customer access to the Products.

5.3. Third Party Products and Services. If GE Healthcare provides Third Party Products and/or Services, then (i) GE Healthcare is acquiring them on Customer's behalf as its agent and not as a supplier; (ii) GE Healthcare provides no warranties or indemnification, express or implied; and (iii) Customer is responsible for all claims resulting from or related to their acquisition or use.

5.4. Mobile Equipment. GE Healthcare will assemble Equipment it has approved for mobile use at the vehicle location identified by Customer. Customer will comply with the vehicle manufacturer's planning requirements and arrange for delivery of the vehicle.

5.5. Audit. GE Healthcare may audit Customer's use of Software, Subscription and Healthcare Digital Products to verify Customer's compliance with this Agreement up to 12 months following termination or expiration of the applicable Quotation. Customer will provide reasonable assistance and unrestricted access to the information. Customer must pay underpaid or unpaid fees discovered during the audit, and GE Healthcare's reasonable audit costs, within 30 days of written notification of the amounts owed. If Customer does not pay, or the audit reveals that Customer is not in compliance, GE Healthcare may terminate Customer's Software license, Subscription or use of the Healthcare Digital Product.

6. **Security Interest and Payment.**

6.1. Security Interest. Customer grants GE Healthcare a purchase money security interest in all Products in the Quotation until full payment is received, and Customer will perform all acts and execute all documents necessary to perfect GE Healthcare's security interest.

6.2. Failure to Pay. If, after Product delivery, Customer is more than 45 days past due on undisputed payments, GE Healthcare may, on 10 days' prior written notice, disable and/or remove the Products.

6.3. Lease. If Customer leases a Product, Customer continues to be responsible for payment obligations under this Agreement.

7. **Trade-In Equipment.** Trade-in equipment identified in a Quotation will be subject to separate trade-in terms and conditions.

8. **Subscriptions.** The following terms apply to all Subscriptions (excluding Healthcare Digital Products).

8.1. Commencement. Unless otherwise indicated in this Agreement or the Quotation, the Subscription commences on the date GE Healthcare provides Customer access to the Products.

8.2. Renewal / Non-Renewal. The Subscription term renews automatically for the same duration as the initial term of the Subscription unless otherwise identified in the Quotation. Except as otherwise identified in this Agreement or a Quotation, GE Healthcare may increase prices annually by no more than the Consumer Price Index for All Urban Consumers (U.S. City Average, December to December) plus 2%, upon 90 days' prior written notice. Subscriptions are not cancellable; however, either party may opt to not renew the Subscription after the initial Subscription term or any subsequent renewal term by providing at least 60 days' prior written notice to the other party prior to renewal.

8.3. Subscription Equipment. Title to Equipment and Third-Party Equipment provided via Subscription ("Subscription Equipment") remains with GE Healthcare. Customer will not place, or permit the placement of, liens, security interests, or other encumbrances on Subscription Equipment. Customer shall not repair or service Subscription Equipment, or allow others to do so, without the prior written consent of GE Healthcare.

8.4. Support Services. Unless otherwise noted in the Quotation, GE Healthcare will provide support Services as described in the Subscription Products and ViewPoint Software Maintenance Terms and Conditions.

8.5. Upgrades. Included in the Subscription fees if Customer does not owe any undisputed payments, GE Healthcare will provide upgrades if and when they become available and to the extent they are provided to all GE Healthcare customers with a Subscription for the Products, at mutually agreed upon delivery and installation dates. Upgrades do not include: (i) any optional or separately licensable features; (ii) any Products not covered by the Subscription; or (iii) any virtual environment required to host an upgraded Product. GE Healthcare shall have no obligation to provide upgrades if Products are not maintained within the current major release version or the immediately prior major release version.

8.6. Access Controls. Customer must: (i) ensure users maintain individually-assigned confidential user credentials and control mechanisms to access the Subscription; and (ii) take reasonable steps to prevent unauthorized access to Products.

8.7. Post-Termination. Upon termination or expiration of the Subscription: (i) Customer must immediately discontinue use of the Products and return Subscription Equipment to GE Healthcare in proper operating condition; (ii) Customer must destroy its copies of Software and Documentation; (iii) Customer must remove its data from Subscription Equipment; (iv) GE Healthcare is not responsible for and may destroy Customer-provided information, images or data; and (v) GE Healthcare will remove Customer's access.

8.8. Professional Services. For Services not covered under this Agreement or required due to Customer not meeting its responsibilities under the Agreement, applicable additional professional Services and fees will be required: (i) identified in the Quotation; and (ii) subject to GE Healthcare's then-current pricing.

9. General Terms.

9.1. Confidentiality. Each party will treat this Agreement and the other party's proprietary information as confidential, meaning it will not use or disclose the information to third parties unless permitted in this Agreement or required by law. Customers are not prohibited from discussing patient safety issues in appropriate venues.

9.2. Governing Law. The law of the state where the Product is installed, the Service is provided, or the Subscription is accessed will govern this Agreement.

9.3. Force Majeure. Performance time for non-monetary obligations will be reasonably extended for delays beyond a party's control.

9.4. Assignment; Use of Subcontractors. Rights and obligations under this Agreement cannot be assigned without the other party's prior written consent, unless: (i) it is to an entity (except to a GE Healthcare competitor) that (a) is an affiliate or parent of the party or (b) acquires substantially all of the stock or assets of such party's applicable business, Product line, or Service thereof; and (ii) the assignee agrees in writing to be bound by this Agreement, including payment of outstanding fees. GE Healthcare may hire subcontractors to perform work under this Agreement but will remain responsible for its obligations.

9.5. Waiver; Survival. If any provision of this Agreement is not enforced, it is not a waiver of that provision or of a party's right to later enforce it. Terms in this Agreement related to intellectual property, compliance, data rights and terms that by their nature are intended to survive will survive the Agreement's expiration or termination.

9.6. Intellectual Property. GE Healthcare owns all rights to the intellectual property in GE Healthcare's Products, Services, Documentation, Specifications, and statements of work related to a Quotation or otherwise. Customer may provide GE Healthcare with feedback related to Products, Services, and related Documentation, and GE Healthcare may use it in an unrestricted manner.

10. Compliance.

10.1. Generally. Each party will comply with applicable laws and regulations. Customer is only purchasing or licensing Products for its own medical, billing and/or non-entertainment use in the United States. GE Healthcare will not deliver, install, service or train if it discovers Products have been or are intended to be used contrary to this Agreement. This Agreement is subject to GE Healthcare's ongoing credit review and approval. Customer is aware of its legal obligations for cost reporting, including 42 C.F.R. § 1001.952(g) and (h), and will request from GE Healthcare any information beyond the invoice needed to fulfill Customer's cost reporting obligations. GE Healthcare will provide safety-related updates for Equipment and Software required by applicable laws and regulations at no additional charge.

10.2. Security. GE Healthcare is not responsible for: (i) securing Customer's network; (ii) preventing unauthorized access to Customer's network or the Product; (iii) backup management; (iv) data integrity; (v) recovery of lost, corrupted or damaged data, images, software or equipment; (vi) third party operating systems, unless specifically provided in the Quotation; or (vii) providing or validating antivirus or related IT safeguards unless sold to Customer by GE Healthcare. NEITHER PARTY WILL BE LIABLE TO THE OTHER PARTY FOR DAMAGES CAUSED BY UNAUTHORIZED ACCESS TO THE NETWORK OR PRODUCTS REGARDLESS OF A PARTY'S COMPLIANT SECURITY MEASURES.

10.3. Environmental Health and Safety ("EHS"). GE Healthcare personnel may stop work without penalty due to safety concerns. Customer must: (i) comply with GE Healthcare's EHS requirements; (ii) provide a safe environment for GE Healthcare personnel; (iii) tell GE Healthcare about chemicals or hazardous materials that might come in contact with Products or GE Healthcare personnel; (iv) perform decommissioning or disposal at Customer facilities; (v) obtain and maintain necessary permits; (vi) thoroughly clean Products before Service; (vii) provide radioactive materials required for testing Products; and (viii) dispose of waste related to Products and installations.

10.4. Parts and Tubes. GE Healthcare: (i) recommends the use of parts it has validated for use with the Product; (ii) is not responsible for the quality of parts supplied by third parties to Customer; and (iii) cannot assure Product functionality or performance when non-validated parts are used. Certain Products are designed to recognize GE Healthcare-supplied tubes and report the presence of a non-GE Healthcare tube; GE Healthcare is not responsible for the use of, or effects from, non-GE Healthcare supplied tubes.

10.5. Training. GE Healthcare's training does not guarantee that: (i) Customer trainees are fully trained on Product use, maintenance or operation; or (ii) training will satisfy any licensure or accreditation. Customer must ensure its trainees are fully qualified in the use and operation of the Product. Unless otherwise identified in the training catalog, Customer will complete training within 12 months of: (a) the date of Product delivery for a Product purchase; (b) the respective start date for Services or Subscription for purchase of Service or Subscription; or (c) the date training is ordered for training-only purchases. If not completed within this time period, other than because of GE Healthcare's fault, training expires without refund.

10.6. Medical Diagnosis and Treatment. All clinical and medical treatment, diagnostic and/or billing decisions are Customer's responsibility.

10.7. Connectivity. If a Product has remote access capability: (i) Customer will provide GE Healthcare with, and maintain, a GE Healthcare-validated remote access connection to service the Product; or (ii) GE Healthcare reserves the right to charge Customer for onsite support at GE Healthcare's then-current billing rate. This remote access and collection of machine data (e.g., temperature, helium level) will continue after the end of this Agreement unless Customer requests in writing that GE Healthcare disable it.

10.8. Use of Data.

10.8.1. Protected Health Information. If GE Healthcare creates, receives, maintains, transmits or otherwise has access to Protected Health Information (as defined in 45 C.F.R. § 160.103) ("PHI"), GE Healthcare may use and disclose the PHI only as permitted by law and by the Business Associate Agreement. Before returning any Product to GE Healthcare, Customer must ensure that all PHI stored in it is deleted.

10.8.2. Data Rights. GE Healthcare may collect, prepare derivatives from and otherwise use non-PHI data related to Products and/or Services for such things as training, demonstration, research, development, benchmarking, continuous improvement and facilitating the provision of its products, software and services. GE Healthcare will own all intellectual property and other rights that could result from this collection, preparation and use. The non-PHI data will not be used to identify Customer or sold by GE Healthcare without Customer's consent.

10.9. Customer Policies. GE Healthcare will use reasonable efforts to respect Customer-provided policies that apply to GE Healthcare and do not materially contradict GE Healthcare policies. Failure to respect Customer policies is not a material breach unless it is willful and adversely affects GE Healthcare's ability to perform its obligations.

10.10. Insurance. GE Healthcare will maintain coverage in accordance with its standard certificate of insurance.

10.11. Excluded Provider. To its knowledge, neither GE Healthcare nor its employees performing Services under this Agreement have been excluded from participation in a Federal Healthcare Program. If an employee performing Services under this Agreement is excluded, GE Healthcare will replace that employee within a reasonable time; if GE Healthcare is excluded, Customer may terminate this Agreement upon written notice to GE Healthcare.

11. Disputes and Arbitration.

11.1. Binding Arbitration. Other than collection matters and actions seeking injunctive relief to prevent or cease a violation of intellectual property rights related to Products or Services, the parties agree to submit all disputes arising under or relating to this Agreement to the American Arbitration Association ("AAA") office closest to the largest metropolitan area of the location where the Product is installed or the Service is provided for binding arbitration conducted in accordance with AAA's then-current Commercial Arbitration Rules. Costs, including arbitrator fees and expenses, will be shared equally, and each party will bear its own attorneys' fees. The arbitrator will have authority to award damages only to the extent available under this Agreement. Nothing in this Section shall allow either party to arbitrate claims of any third-party not a party to this Agreement. The parties further agree to keep confidential: (i) the fact that any arbitration occurred, (ii) the results of any arbitration, (iii) all materials used, or created for use, in the arbitration, and (iv) all other documents produced by another party in the arbitration and not otherwise in the public domain.

12. Liability and Indemnity.

12.1. Limitation of Liability. GE HEALTHCARE'S LIABILITY FOR DIRECT DAMAGES TO CUSTOMER UNDER THIS AGREEMENT WILL NOT EXCEED: (I) FOR PRODUCTS, THE PRICE FOR THE PRODUCT THAT IS THE BASIS FOR THE CLAIM; OR (II) FOR SERVICE, OR SUBSCRIPTIONS, THE AMOUNT OF SERVICE, OR SUBSCRIPTION FEES FOR THE 12 MONTHS PRECEDING THE ACTION THAT IS THE BASIS FOR THE CLAIM. THIS LIMITATION WILL NOT APPLY TO GE HEALTHCARE'S DUTIES TO INDEMNIFY CUSTOMER UNDER THIS AGREEMENT.

12.2. Exclusion of Damages. NEITHER PARTY WILL HAVE ANY OBLIGATION FOR: (I) CONSEQUENTIAL, PUNITIVE, INCIDENTAL, INDIRECT OR REPUTATIONAL DAMAGES; (II) PROFIT, DATA OR REVENUE LOSS; OR (III) CAPITAL, REPLACEMENT OR INCREASED OPERATING COSTS.

12.3. IP Indemnification. GE Healthcare will indemnify, defend and hold Customer harmless from third-party claims for infringement of United States intellectual property rights arising from Customer's use of the Equipment or Software in accordance with the Specifications, Documentation and license.

12.4. General Indemnification.

12.4.1. GE Healthcare will indemnify, defend and hold Customer harmless for losses which Customer becomes legally obligated to pay arising from third party claims brought against Customer for bodily injury or damage to real or tangible personal property to the extent the damage was caused by GE Healthcare's: (i) design or manufacturing defect; (ii) negligent failure to warn, negligent installation or negligent Services; or (iii) material breach of this Agreement.

12.4.2. Customer will indemnify, defend and hold GE Healthcare harmless for losses which GE Healthcare becomes legally obligated to pay arising from third party claims brought against GE Healthcare for bodily injury or damage to real or tangible personal property to the extent the damage was caused by Customer's: (i) medical diagnosis or treatment decisions; (ii) misuse or negligent use of the Product; (iii) modification of the Product; or (iv) material breach of this Agreement.

12.5. Indemnification Procedure. For all indemnities under this Agreement: (i) the indemnified party must give the other party written notice before claiming indemnification; (ii) the indemnifying party will control the defense; (iii) the indemnified party may retain counsel at its own expense; and (iv) the indemnifying party is not responsible for any settlement without its written consent.

13. Payment and Finance.

13.1. Late Payment. Customer must raise payment disputes before the payment due date. For any undisputed late payment, GE Healthcare may: (i) suspend performance under this Agreement until all past due amounts are paid; (ii) charge interest at a rate no more than the maximum rate permitted by applicable law; and (iii) use unapplied funds due to Customer to offset any of Customer's outstanding balance. If GE Healthcare suspends performance, any downtime will not be included in the calculation of any uptime commitment. If Customer fails to pay when due: (a) GE Healthcare may revoke its credit and designate Customer to be on credit hold; and (b) all subsequent shipments and Services must be paid in full on receipt.

13.2. Taxes. Prices do not include applicable taxes, which are Customer's responsibility.

13.3. Customer Payment Obligation. If installation or acceptance is delayed more than 90 days because of any reason for which Customer or its subcontractor is responsible, GE Healthcare will provide written notice and bill the remaining balance due on the order, and Customer must pay according to the payment terms listed on the Quotation.

14. Notices. Notices will be in writing and considered delivered when received if sent by certified mail, postage prepaid, return receipt requested, by overnight mail, or by fax. Notice to Customer will be directed to the address on this Agreement, and notice to GE Healthcare to General Counsel, 9900 Innovation Dr., Wauwatosa, WI 53226.

15. Imaging Equipment Uptime Commitment. GE Healthcare will provide an uptime commitment during warranty for CT, MR, nuclear imaging, and x-ray Equipment, excluding peripherals ("Eligible Equipment") if Customer provides GE Healthcare with: (i) access to Eligible Equipment through a secure connection meeting Specifications and industry best practices; (ii) notice of changes that impact Customer's connection; and (iii) prompt and unencumbered access to Eligible Equipment. The "Uptime Commitment" for nuclear imaging and x-ray Eligible Equipment is 95%, except digital mammography, digital radiographic and vascular x-ray systems and all other Eligible Equipment is 97%. Other Products may be eligible for an uptime commitment if identified in the Quotation.

If GE Healthcare fails to meet the Uptime Commitment over a 26-week period, it will extend the warranty as follows:

<u>% Less than Uptime Commitment</u>	<u>Warranty Extension</u>
--------------------------------------	---------------------------

0.1 - 3.0	1 week
3.1 - 8.0	2 weeks
8.1 - 13.0	4 weeks
> 13.0	6 weeks

Uptime is calculated as follows:

$$\left(\frac{\text{UptimeBase} - \text{Downtime}}{\text{UptimeBase}} \right)$$

“Uptime Base” = (“a” hours per day X “b” days per week X 26 weeks) – (Planned Maintenance (“PM”) hours during prior 26 weeks), where “a” hours per day and “b” days per week are determined by the standard warranty for Eligible Equipment. “Downtime” is the number of hours during which Eligible Equipment is subject to a Critical Malfunction. Downtime starts when Customer notifies GE Healthcare that Eligible Equipment is inoperable and unavailable for use due to GE Healthcare’s design, manufacturing, material or performance failure (“Critical Malfunction”). Downtime ends when Eligible Equipment is available for clinical use. To be eligible for the Uptime Commitment, Customer must maintain a performance log that includes data required to calculate Downtime.

16. DoseWatch Device License. Each connection of a Device (defined below) to the DoseWatch Software requires Customer to purchase a unique Device license referencing a Device ID that allows concurrent use of the DoseWatch Software with that Device at a specified Customer facility on Customer’s secured network. All other terms, duration and warranties applicable to the Software license apply to the Device license. “Device” is specific Customer equipment approved by GE Healthcare to be connected to DoseWatch Software under this Agreement. Additional Device connections may be added to this Agreement, subject to individual Device licenses, and related installation, implementation, configuration and optimization services at GE Healthcare’s then-current rates.

17. Subscription Products and ViewPoint Software Maintenance Terms and Conditions.

17.1. Overview. GE Healthcare will, in accordance with the terms and conditions of this section, maintain, support and update: (i) Products provided via Subscription (excluding Healthcare Digital Products); and (ii) ViewPoint Software licensed by Customer (“ViewPoint Software”) and HIS interface software installed in the United States covered by a Software Maintenance Agreement (“SMA”).

17.2. Scope.

17.2.1. Software Support and Maintenance. GE Healthcare will use reasonable efforts to provide Error Correction (defined below) for verifiable and reproducible Errors (defined below) within a reasonable time after: (a) Customer reports the Error to GE Healthcare; or (b) detection by GE Healthcare. Updates (defined below), if released, will be provided at no additional cost as a part of this maintenance commitment. New functionality must be purchased separately, unless otherwise agreed.

17.2.2. Equipment Maintenance. Preventative maintenance service may be required periodically during normal business hours of 8:00 a.m. to 5:00 p.m. (local time) on mutually agreed dates. Customer will make the Equipment available for preventative maintenance upon GE Healthcare request. Additional services to be performed, including specific additional terms thereof, shall be specified in the Quotation or alternate schedules.

17.2.3. Definitions. “Error” means any Software-related problem that: (i) materially interferes with Customer’s use of the Software; and (ii) results from a failure of the Software to materially conform to the Documentation. “Error Correction” means: (a) modification of the Software that corrects an Error by bringing the Software into material conformity with the Documentation; or (b) a procedure that avoids the material adverse effect of the nonconformity. “Update” means a change that provides Error Corrections and/or enhances functionality of the Software version licensed by Customer. An Update does not involve major changes or provide significant, new functionality or applications, or changes to the software architecture or file structure. Updates retain the same license as the original Software.

17.2.4. Hotline Support. GE Healthcare will provide phone and email support during standard business hours, excluding GE Healthcare holidays, for problem solving, Error resolution and general help.

17.2.5. Remote Access Support. GE Healthcare may access Software remotely via Customer’s network and GE Healthcare-supplied secure tunnelling software to monitor Software parameters to help prevent and detect Errors. Customer will reasonably cooperate with GE Healthcare to establish remote connections. Certain modules require remote access in order to obtain support.

17.2.6. Warranty. GE Healthcare warrants that its Services will be performed by trained individuals in a professional, workman-like manner. GE Healthcare will re-perform non-conforming Services as long as Customer provides prompt written notice to GE Healthcare. NO OTHER EXPRESS OR IMPLIED WARRANTIES, INCLUDING IMPLIED WARRANTIES OF NON-INFRINGEMENT, MERCHANTABILITY AND FITNESS FOR A PARTICULAR PURPOSE, WILL APPLY. SERVICE MANUALS AND DOCUMENTATION ARE PROVIDED “AS IS”. GE HEALTHCARE DOES NOT GUARANTEE PRODUCTS WILL OPERATE WITHOUT ERROR OR INTERRUPTION.

17.2.7. Exclusions. GE Healthcare has no obligation to Customer for: (i) use of Products in combination with software, hardware, or services not recommended in writing by GE Healthcare; (ii) use in a manner or environment for which GE Healthcare did not design or license the Products, or in violation of GE Healthcare’s recommendations or instructions; (iii) interface configuration (often referred to as HIS, PACS or EMR interfaces necessary due to changing vendors or versions); (iv) reorganization of Customer data; (v) consulting or software engineering and programming; (vi) support of Products outside the scope of the foregoing maintenance commitments; (vii) failure to use or install, or permit GE Healthcare to use or install, Error Corrections or Updates; (viii) failure to maintain Products within the current major release version or the immediately prior major release version; (ix) defects in products or services not made and provided by GE Healthcare; (x) any cause external to the Products or beyond GE Healthcare’s control; (xi) failure of Customer’s network; (xii) replacement of disposable or consumable items; (xiii) additional equipment or upgrades in connection with Products; and (xiv) migration of Software to different hardware or operating systems.

17.2.8. Software Maintenance Agreement Term. The following applies to ViewPoint software and HIS interface software only: The SMA term and start date is identified in the Quotation and its related Schedule A. Either party may terminate the SMA without cause after the first anniversary by providing at least 90 days' prior written notice to the other party. SMA payments are due within 30 days after receipt of GE Healthcare's invoice.

17. **Magnetic Resonance ("MR") – Magnetic Maintenance and Cryogenics**. Customer is responsible for: (i) cryogen loss due to power loss or water chiller failure for the MR's shield cooler or condenser system during installation; (ii) costs for cryogen replacement plus transfill labor at GE Healthcare's then-applicable rates; (iii) post-assembly supply and installation of cryogenics, unless cryogen loss is caused by a defect in material or workmanship within the scope of GE Healthcare's warranty. MR magnetic fields attract ferro-magnetic articles and are capable of rapidly accelerating them toward the magnet, creating danger to persons in the vicinity and possible system damage. Magnetic and radio frequency fields may adversely affect the operation of pacemakers, equipment containing magnetic reed switches and aneurysm or surgical clips.



1. Warranty.

1.1 **Equipment.** For non-customized Equipment purchased from GE Healthcare or its authorized distributors, unless otherwise identified in the Quotation, GE Healthcare warrants that Equipment will be free from defects in title, and, for 1 year from Equipment Acceptance, it will: (i) be free from defects in material and workmanship under normal use and service; and (ii) perform substantially in accordance with the Specifications. The warranty covers parts and labor and only applies to end-users that purchase Equipment from GE Healthcare or its authorized distributors.

1.2 **Software.** For Software licensed from GE Healthcare, GE Healthcare warrants that: (i) it has the right to license or sublicense Software to Customer; (ii) it has not inserted Disabling Code into Software; (iii) it will use efforts consistent with industry standards to remove viruses from Software before delivery; and (iv) unless otherwise identified in the Quotation, for 90 days from Software Acceptance, Software will perform substantially in accordance with the Documentation. “Disabling Code” is code designed to interfere with the normal operation of Software, but code that prohibits use outside of the license scope is not Disabling Code.

1.3 **Services.** GE Healthcare warrants that its Service will be performed by trained individuals in a professional, workman-like manner.

1.4 **Used Equipment.** Certain Used Equipment is provided with GE Healthcare’s standard warranty for the duration identified in the Quotation, but in no event more than 1 year. If no warranty is identified, the Used Equipment is provided “AS IS” and is not warranted by GE Healthcare.

1.5 **Accessories and Supplies.** Warranties for accessories and supplies are at www.gehealthcare.com/accessories.

1.6 **Third Party Product.** Third Party Product is covered by the third party’s warranty and not GE Healthcare’s warranties.

1.7 **Subscription Products.** Products provided via Subscription (excluding Healthcare Digital Products) are not covered by this Warranty Statement. Instead, the Subscription Products and ViewPoint Software Maintenance Terms and Conditions apply

2. **Remedies.** If Customer promptly notifies GE Healthcare of its claim during the warranty and makes the Product available, GE Healthcare will: (i) at its option, repair, adjust or replace the non-conforming Equipment or components; (ii) at its option, correct the non-conformity or replace the Software; and/or (iii) re-perform non-conforming Service. Warranty service will be performed from 8am to 5pm local time, Monday-Friday, excluding GE Healthcare holidays, and outside those hours at GE Healthcare’s then-current service rates and subject to personnel availability. GE Healthcare may require warranty repairs to be performed via a secure, remote connection or at an authorized service center. If GE Healthcare replaces Equipment or a component, the original becomes GE Healthcare property and Customer will return the original to GE Healthcare within 5 days after the replacement is provided to Customer. Customer cannot stockpile replacement parts. Prior to returning Equipment to GE Healthcare, Customer will: (a) obtain a return to manufacturer authorization; and (b) back up and remove all information stored on the Equipment (stored data may be removed during repair). Customer is responsible for damage during shipment to GE Healthcare. The warranty for a Product or component provided to correct a warranty failure is the unexpired term of the warranty for the repaired or replaced Product.

GE Healthcare may provide a loaner unit during extended periods of Product service. If a loaner unit is provided: (i) it is for Customer’s temporary use at the location identified in the Quotation; (ii) it will be returned to GE Healthcare within 5 days after the Product is returned to Customer, and if it is not, GE Healthcare may repossess it or invoice Customer for its full list price; (iii) it, and all programs and information pertaining to it, remain GE Healthcare property; (iv) risk of loss is with Customer during its possession; (v) Customer will maintain and return it in proper condition, normal wear and tear excepted, in accordance with GE Healthcare’s instructions; (vi) it will not be repaired except by GE Healthcare; (vii) GE Healthcare will be given reasonable access to it; (viii) Customer is not paying for its use, and Customer will ensure charges or claims submitted to a government healthcare program or patient are submitted accordingly; and (ix) prior to returning it to GE Healthcare, Customer will delete all information, including PHI, from it and its accessories, in compliance with industry standards and instructions provided by GE Healthcare.

NO OTHER EXPRESS OR IMPLIED WARRANTIES, INCLUDING IMPLIED WARRANTIES OF NON-INFRINGEMENT, MERCHANTABILITY AND FITNESS FOR A PARTICULAR PURPOSE, WILL APPLY. SERVICE MANUALS AND DOCUMENTATION ARE PROVIDED “AS IS”. GE HEALTHCARE DOES NOT GUARANTEE PRODUCTS WILL OPERATE WITHOUT ERROR OR INTERRUPTION.

3. **Limitations.** GE Healthcare has no obligation to Customer for warranty claims if Customer uses the Product: (a) for non-medical or entertainment use or outside the United States; (b) in combination with software, hardware, or services not recommended in writing by GE Healthcare; and (c) in a manner or environment for which GE Healthcare did not design or license it, or in violation of GE Healthcare’s recommendations or instructions.

In addition, these warranties do not cover: (i) defects or deficiencies from improper storage or handling, maintenance or use that does not conform to Specifications and/or Documentation, inadequate backup or virus protection, cyber-attacks, failure to maintain power quality, grounding, temperature, and humidity within Specifications and/or Documentation; (ii) repairs due to power anomalies or any cause external to the Products or beyond GE Healthcare’s control; (iii) payment or reimbursement of facility costs arising from repair or replacement of the Products or parts; (iv) planned maintenance (unless applicable to Equipment), adjustment, alignment, or calibration; (v) network and antenna installations not performed by GE Healthcare or its subcontractors; (vi) lost or stolen Products; (vii) Products with serial numbers altered, defaced or removed; (viii) modification of Product not approved in writing by GE Healthcare (ix) Products immersed in liquid; and (x) replacement of disposable or consumable items.

4. Exceptions to Standard Warranty.

DoseWatch Explore: DOSEWATCH EXPLORE SOFTWARE, SERVICES AND INFORMATION IS PROVIDED “AS IS” WITH NO WARRANTY

Partial System Equipment Upgrades for CT, MR, X-Ray, IGS, PET (Scanners, Cyclotrons and Chemistry Labs) and Nuclear systems: 6 months (only applies to the upgraded components unless the parties otherwise agree to modify the coverage of the upgraded and existing components in an existing service agreement. Optima XR240amx partial upgrades are warranted for 1 year

Cyclotron and Radiopharmacy: Warranty starts on the earlier of (i) 3 months after the date GE Healthcare completes mechanical installation, Warranty Statement (Rev 01.30.20)

or (ii) the date Product testing is successfully completed

MR Systems: Warranty does not cover: (i) a defect or deficiency from failure of water chillers supplied or serviced by Customer, and (ii) for MR systems with LHe/LN or shield cooler configured superconducting magnets (except for MR Systems with LCC magnets), any cryogen supply, cryogenic service or service to the magnet, cryostat, coldhead, shield cooler compressor or shim coils unless the need for supply or service is caused by a defect in material or workmanship covered by this warranty.

Proteus XR/a, Definium and Precision 500D X-Ray Systems: Warranty does not cover collimator bulbs

Performix 160A (MX160) Tubes: 3 years

X-Ray High Voltage Rectifiers and TV Camera Pick-Up Tubes: 6 months

X-Ray Wireless Digital Detectors: In addition to the standard warranty, GE Healthcare will provide coverage for detector damage due to accidental dropping or mishandling. If accidental damage occurs, GE Healthcare will provide Customer with 1 replacement detector during warranty at no additional charge. If subsequent accidental damage occurs during warranty, each additional replacement will be provided for \$30,000 per replacement. This additional coverage excludes damage caused by any use that does not conform to original equipment manufacturer ("OEM") guidelines, use that causes fluid invasion, holes, deep scratches or the detector case to crack, and damage caused by abuse, theft, loss, fire, power failures or surges. If the warranty is voided by these conditions, repair or replacement is Customer's responsibility.

Bone Mineral Densitometry: Alpha Source, Inc. will perform installation, application support and warranty services. Direct warranty claims to Alpha Source, Inc. at 1-800-654-9845. Upgraded computer, printer and monitor components include a 1 month warranty. Customer will not be credited the value of this warranty against pre-existing warranties or service agreements.

OEC New or Exchange Service Parts: 120 days

OEC Tubes and Image Intensifiers: 1 year

OEC Refurbished C-Arms: 1 year after installation

IGS Large Display Monitor: Warranty coverage excludes damage caused by Customer abuse

HealthNet Lan, Advantage Review — Remote Products: 3 months

LOGIQ e, Venue 50, Venue Go, Versana Active and related transducers purchased with them: 5 years

LOGIQ V1, LOGIQ V2, Vivid iq, Vscan and Vscan Extend and related transducers purchased with them: 3 years

Except the following have a 1 year warranty:

Transducers: TEE Probes,

Carts: Venue 50 Docking Cart, Venue Go Cart, Venue Go mounting cradle, LOGIQ e Isolation Cart, LOGIQ e Docking Cart, and LOGIQ V1/V2 Cart

Other Accessories: Batteries (internal & external), and printers and peripherals, TEE cleaning & storage system, ICECord Connector and printers

Warranty covers defective parts and components and includes: (i) repair at GE Healthcare facilities, (ii) a loaner unit or probe replacement shipped for next business day delivery for requests received by 3pm Central Time, (iii) phone support from 7am to 7pm Central Time, Monday-Friday, excluding GE Healthcare holidays. For an additional charge, GE Healthcare may provide field support/service, planned maintenance, and/or coverage for damage due to accidental dropping or mishandling.

LOGIQ P9 R2.5 and newer and, Versana Premier, Versana Balance, Venue and related transducers purchased with them: 5 years

Voluson P8 BT18 and newer, LOGIQ F8 2016 and newer, LOGIQ V5, Vivid T8 and Vivid T9 along with related transducers purchased with them: 3 years

Except the following have a 1 year warranty:

Other Accessories: Batteries (internal & external) and printers and peripherals, TEE cleaning & storage system

Transducers: TEE Probes

Warranty covers defective parts and components and includes: (i) repair at Product location by a qualified service technician Monday-Friday 8am to 5pm local time, excluding GE Healthcare holidays, and (ii) phone support from 7am to 7pm Central Time, Monday-Friday, excluding GE Healthcare holidays. For an additional charge, GE Healthcare may provide planned maintenance and/or coverage for damage due to accidental dropping or mishandling.

Ultrasound Partial System Equipment Upgrades: 3 months (only applies to the upgraded components). Customer will not be credited the value of the warranty against pre-existing warranties or service agreements.

Veterinary Use: Notwithstanding anything herein, any Product validated and sold by GE Healthcare for specific use in the veterinary market shall have a one (1) year warranty.

Batteries: 3 months, except for x-ray nickel cadmium or lead acid batteries and ultrasound batteries, which are warranted for 1 year

CARESCAPE Monitors B450, B650 and B850: 3 years parts, 1 year labor (excluding displays, which are standard)

B40 Monitors: 2 years parts, 1 year labor (excluding displays, which are standard)

B105 and B125 Patient Monitors: 3 years parts and labor coverage with: (i) repair services performed at GE Healthcare Repair Operations Center, (ii) phone support from 7am to 5pm Central Time, Monday-Friday, excluding GE Healthcare holidays; and (iii) a loaner Product (subject to availability; shipping charges included).

Novii Wireless Patch System- Interface and Pods: 1 year starting 40 days after shipment with: (i) exchange services performed at GE Healthcare Repair Operations Center; and (ii) phone support from 7am to 5pm Central Time, Monday-Friday, excluding GE Healthcare holidays. Customer may elect to purchase coverage for Pod damage due to accidental dropping or mishandling. This coverage excludes patches and cables, which are considered Product accessories, and are warranted pursuant to Section 1.5 above.

MAC 2000 and 3500: 3 years

CARESCAPE V100 and VC150 Vital Signs Monitors: 2 years

CARESCAPE T14 Transmitter: 2 years

SEER 1000: 2 years

Exergen: 4 years

Panda® iRes Warmers, Giraffe® Warmer and Giraffe® Carestation OmniBed: 7 year parts warranty on heater cal rod

Microenvironment and Phototherapy consumable components: 1 month

Corometrics® Fetal Monitoring: Warranty includes: (i) warranty starting on the earlier of (a) if GE Healthcare or Customer installs, 5 days after installation or (b) 40 days after shipment; and (ii) 2 years parts, 1 year labor

Corometrics® Nautilus Transducers: 2 years

Lullaby Phototherapy System: 3 years on lamp assembly

Blood pressure cuffs and related adaptors and air hoses: 1 month

Anesthesia Monitor Mounting Solutions: If purchased directly from GE Healthcare, it will be warranted as a GE Healthcare Product

Tec 850 Vaporizers: 3 years

Tec 6 Plus Vaporizers: 2 years

CARESCAPE Gateway: 1 year

CARESCAPE Bridge: 1 year

Andy Lamb

From: Sean Chen <chen@grandmedicalequipment.com>
Sent: Tuesday, February 23, 2021 12:50 PM
To: Andy Lamb
Subject: Re: DOTmed Listing #3458711 MRI Scanner, Signa HDx 1.5T by GE

[External Email] This email originated from outside of the organization. **Think before you click:** Don't click on links, open attachments or respond to requests for sensitive information if the email looks suspicious or you don't recognize the sender.

That is \$65,000 as is where is. The system is still up and running in clinical use.
Sean

On Tue, Feb 23, 2021 at 12:27 PM Andy Lamb <auto@dotmed.com> wrote:

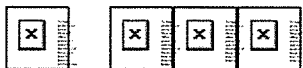

An Unregistered user of DOTmed.com sent you this email.

You are receiving this BECAUSE YOUR LISTINGS ARE UPGRADED.

Andy Lamb of Rutland Regional Medical Center sent you this email regarding Listing #3458711, GE Signa HDx 1.5T MRI Scanner.

Contact Info:

Andy Lamb
Rutland Regional Medical Center
ajlamb@rrmc.org
RUTLAND

Message:

What is your asking price?

Click here to view the full listing information:
<https://www.dotmed.com/listing/3458711>

Access and use of the site DOTmed.com is subject to the terms and conditions of our [LEGAL NOTICE & PRIVACY NOTICE](#) therein.
Property of and Proprietary to DOTmed.com, Inc.
Copyright DOTmed.com, Inc.
ALL RIGHTS RESERVED

--

Grand Medical Equipment, Inc.

3 Corporate Drive

Cranbury, NJ 08512, USA

Phone: 609-610-6925

web store: <http://www.dotmed.com/virtual-trade-show/booth/102949> Grand Medical Equipment, Inc

Equipment type, model or mfg



[Home](#) [Equipment](#) ▾ [Parts](#) ▾ [Service](#) ▾ [Companies](#) [Auctions](#) [News](#) [Forums](#) [Career](#)

[Equipment Listings](#) ▸ [MRI](#) ▸ [MRI Scanner](#) ▸ [GE](#) ▸ [Listing #3458711](#)

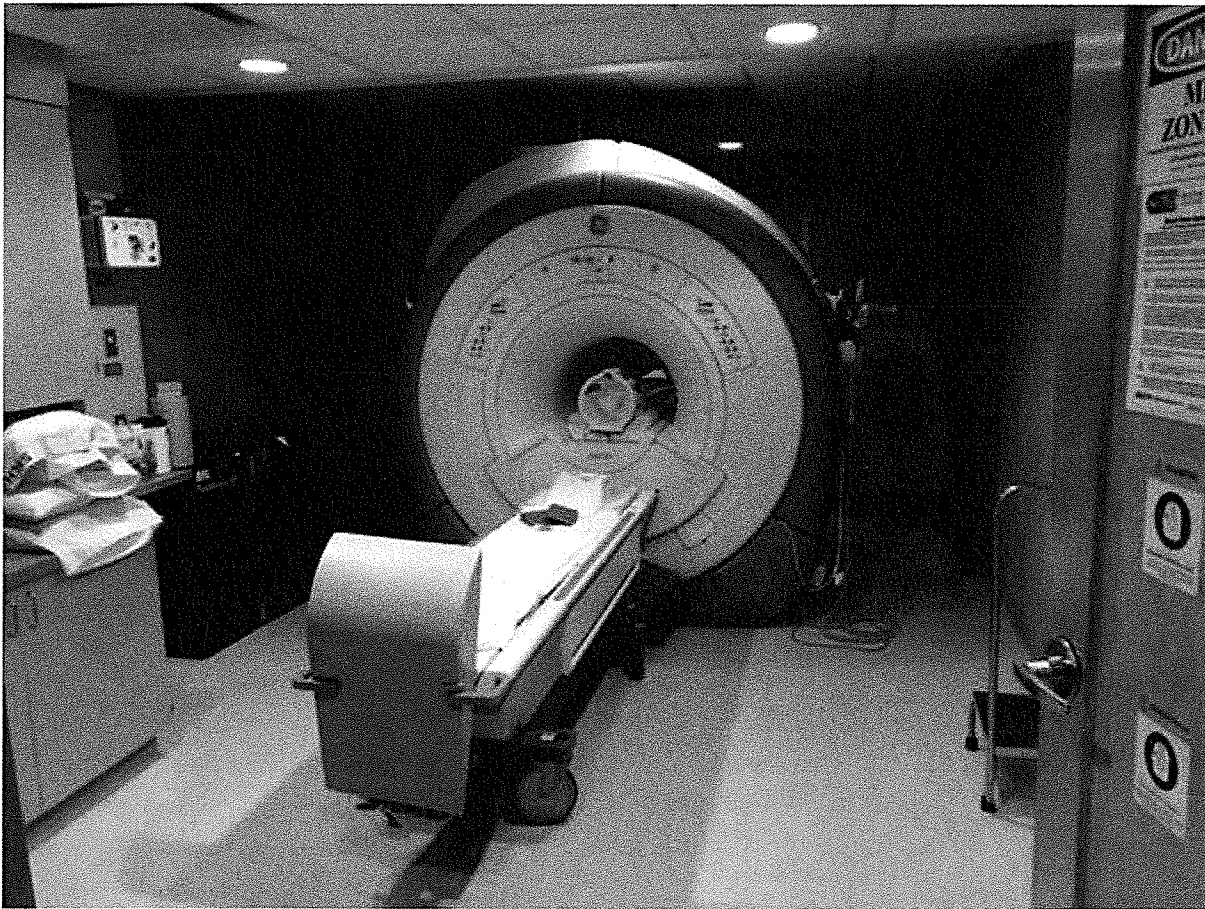

For Sale Scanner

Condition :

Qty. Available :

In Stock :

Date :

.....



EN

Buy

Sell

About

Cart

My DOTmed

Login

One Source to Maximize MRI Scanner Performance

New Listings Post Listing Post Auction Advertise

GE Signa HDx 1.5T MRI

Used - Good

1

Yes

February 18, 2021

Seller Information

Grand Medical Equipment, Inc.

Sean Chen ★★★★★ (60)

Location: **NJ, USA**

Phone: +1 (609) 610-6925

Contact Seller

Buy This Item

Get Financing

Forward Listing

Shop with confidence



See Other Items :

Visit Webstore



For Sale GE Signa EXCITE EchoSpeed Plus 1.5T MRI Scanner

Asking Price: \$335,000.00 USD

Condition: Used - Excellent

Qty. Available: 1

In Stock: Yes

Date: February 21, 2021

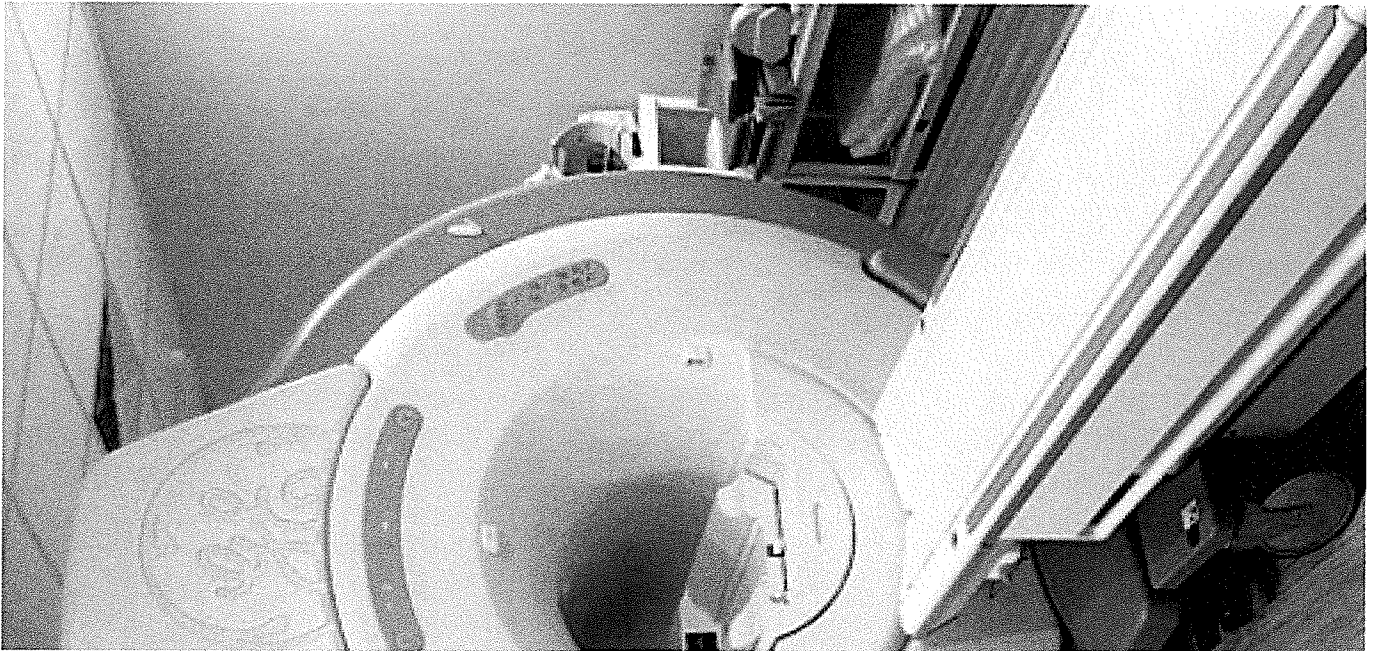

[Buy This Item](#)

[Make An Offer](#)

[Return Policy](#)

Hi! Sign in

Sell Watchlist My eBay



Search for anything

Sign in to eBay with Google

Back to search results | Listed in category: Business & Industrial > Healthcare, Lab & Dental > Medical & Lab Equipment, Devices > Other Medical

Arthur Tennant
tennanta@sunyacc.edu

Continue as Arthur

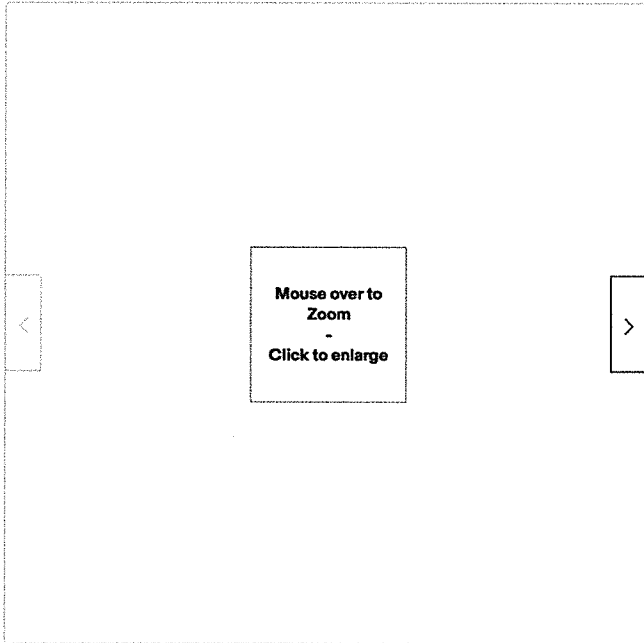

2008 GE Signa HDx 1.5T MRI

Condition: **Seller refurbished**
"Excellent and in working condition."

Price: **US \$65,000.00**

Buy it Now

Add to cart

Best Offer:

Make Offer

Add to Watchlist

Shop with confidence

eBay Money Back Guarantee
Get the item you ordered or your money back. [Learn more](#)

Seller information
med_imaging_phone_267_64 (1799)
100% Positive feedback

Save this Seller
Contact seller
Visit store
See other items

30-day returns

Ships from United States

18 watchers

Shipping: **\$128.34** Standard Shipping | [See details](#)

Item location: San Diego, California, United States

Ships to: United States | [See exclusions](#)

Delivery: Estimated on or before **Wed, Sep. 30** to 05701

Payments:

Earn up to 5x points when you use your eBay Mastercard®. [Learn more](#)



Have one to sell? [Sell now](#)

Returns: 30 day returns. Buyer pays for return shipping | [See details](#)

Similar sponsored items 1/2

Feedback or

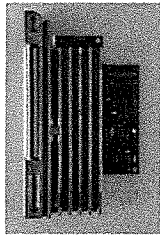

Philips Siemens CT MRI Detector Module (Part #...)
\$9,999.99
Free shipping
Seller 99.8% positive

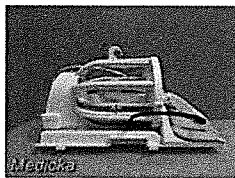

GE Medrad M64NVA 4-Channel Neurovascular...
\$2,070.84
~~\$2,494.99~~
+ \$29.99 shipping
Seller 99.6% positive



Medrad PATIENT MODULE MRI BATTERY Indicator...
\$29.95
+ \$9.00 shipping
Seller 100% positive



INVIVO 2926 Neonatal Quadtrode MRI ECG...
\$8.99
+ \$5.00 shipping
Seller 100% positive



BRUKER BGU II X Y Z NMR BGU2 GRAD H5380...
\$51.00
+ \$47.58 shipping
Seller 99.9% positive



Shell 5500278 Atf Hdx 20Ltr
\$175
+ \$10 shipping
New

Related sponsored items 1/2

Feedback or



GE Signa 1.5T 2275752 Scan Control Module wit...
\$547.50
Free shipping

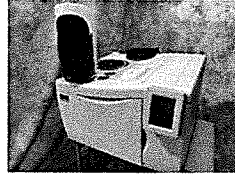

Perkin Elmer Clarus 500 Gas Chromatograph...
\$2,699.99
+ \$350.00 shipping



Beckman Coulter System Gold HPLC System 508,...
\$1,190.00
+ \$250.00 shipping

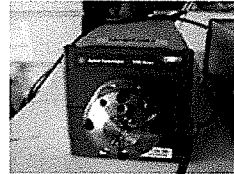

Working 1200 ser. Agilent G1159A 6-Pos. Column...
\$450.00
+ \$2792 shipping

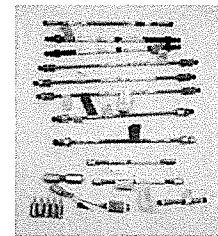

Lot of HPLC Columns for parts/repair - Agilent,...
\$87.99
~~\$109.99~~
Free shipping



Thermo Dione 3000 HPLC | V
\$18,000.00
+ shipping
Last one

Description

Shipping and payments

eBay item number: 174

Seller assumes all responsibility for this listing.

Item specifics

Condition: Seller refurbished :
Seller Notes: "Excellent and in working condition."
Model: GE SIGNA Brand: GE
UPC: Does not apply

All About MRI

med_imaging_phone_267_666_0633 (1799) 100%

Visit Store: All At

Sign up for newsletter

MRI Parts | MRI Coils | Fixed MRI | Mobile MRI | MRI Accessories

OEM: GE
Model: Signa HDx
Tesla: 1.5T
DOM: August 2008
SN: 290192MR4
Helium level: 65.56
HE pressure: 3.935 PSI
MR Software release: 15.0_0947a

Coils

High Resolution Wrist Coil pn: M1087HW & M1887HW
HD Neurovascular Array pn: M3087JJ
Phased array Shoulder coil pn: M1087SE
quadrature knee/ foot coil pn: 472GE-64
HD 8CH brain array pn: 8146634-2
pn: 237136-2
8 Ch Body array pn: UI-100393
High resolution wrist pn: 2293670-2
8 CH CTL coil pn: 5269130
HD Neurovascular array pn: 5117092-2

Additional Accessories

Medrad Solaris Dual head pedestal mount contrast injector

Feedback





RRMC MRI Budget Estimate REV 8 04/27/21

Summary Sheet

Construction Cost estimate			\$848,418
Owner /soft cost: to include A/E fees, attorneys etc..	allow	20.304%	\$172,263
FFE, percentage on construction costs	allow	10.00%	\$84,842
MRI Cost, removed per owner request. Owner will cover in their cost sheet to CON			\$0
MRI compatible monitor, removed per owner request. Owner will cover in their cost sheet to CON			\$0
Infusion pump, removed per owner request. Owner will cover in their cost sheet to CON			\$0
Owner Contingency, percentage on construction costs	allow	10.00%	\$84,842
Total Project cost			\$1,190,365

3:00 PM
4/27/2021

S:\Proposal\RRMC MRI E1421\Estimates\RRMC MRI Budget Estimate REV 8 04.27.21



RRMC MRI Budget Estimate REV 8 04/27/21

Project: RRM MRI Renovations
 Architect: Lavalley Brensinger

printed on 04/27/21

ITEM	DESCRIPTION	QUAN	U/M	UNIT LABOR	LABOR	UNIT MAT'L	MAT	SUB COST	TOTAL
1	GENERAL CONDITIONS				\$45,866		\$70,859	\$0	\$116,725
2	DEMOLITION & ALTERATIONS				\$17,530		\$14,210	\$0	\$31,740
3	CONCRETE				\$0		\$3,500	\$0	\$3,500
4	MASONRY				\$0		\$0	\$0	\$0
5	METALS				\$0		\$0	\$0	\$0
6A	ROUGH CARPENTRY				\$1,250		\$1,250	\$0	\$2,500
6B	FINISH CARPENTRY & MILLWORK				\$0		\$0	\$0	\$0
7	THERMAL & MOISTURE PROTECTION				\$675		\$14,370	\$0	\$15,045
8	DOORS, WINDOWS & GLASS				\$2,540		\$48,930	\$0	\$51,470
9	FINISHES				\$6,958		\$68,299	\$0	\$75,257
10	SPECIALTIES				\$0		\$2,176	\$0	\$2,176
11	EQUIPMENT				\$0		\$0	\$0	\$0
12	FURNISHINGS				\$2,315		\$14,415	\$0	\$16,730
13	SPECIAL CONSTRUCTION				\$1,558		\$16,150	\$29,200	\$46,908
14	CONVEYING SYSTEMS				\$0		\$0	\$0	\$0
21	FIRE SUPPRESSION				\$0		\$6,050	\$0	\$6,050
22	PLUMBING				\$2,400		\$450	\$0	\$2,850
23	HEATING, VENTILATING, AND AIR-CONDITIONING (HVAC)				\$0		\$8,000	\$184,500	\$192,500
25	INTEGRATED AUTOMATION				\$0		\$0	\$0	\$0
26	ELECTRICAL				\$0		\$34,268	\$125,290	\$159,558
27	COMMUNICATIONS				\$0		\$0	\$0	\$0
28	ELECTRONIC SAFETY & SECURITY				\$0		\$0	\$0	\$0
31	EARTHWORK				\$0		\$2,800	\$0	\$2,800
32	EXTERIOR IMPROVEMENTS				\$0		\$1,600	\$0	\$1,600
33	UTILITIES				\$0		\$0	\$0	\$0
Estimate Assumptions:									
* Estimate is based on LBA Progress Set dated 1/7/2019 and LN MEP narrative dated 1/21/19.									
* No winter conditions.									
* No structural upgrades if the new unit is in a different location or to accommodate weight of the MRI unit.									
					\$81,092		\$307,327	\$338,990	\$727,409

CM Estimating Contingency	10.00%	\$72,741
sub tot		\$800,150
G.C. BOND		\$6,577
sub tot		\$806,727
CM FEE	5.00%	\$41,691
TOTAL		\$848,418

Building Floor Areas:

Renovations	1210 sf
Total Building	1,210 sf
Cost /SF	\$701.17

The construction estimate excludes typical owner costs such as:

- Property
- Environmental clearance
- Mold Remediation
- Abatement of Hazardous Materials
- Legal/Administrative
- Financing
- Clerk of the Works/Owners Representative
- Architectural and Special Consultants Fees and Reimbursables
- Moving Costs
- Utility Company Charges
- Permits
- Furnishings (System Furnishings, Furniture, Loose Equipment, etc.)
- Interior Signage
- Owner Provided Equipment and Wire
- Property Insurance, Builder's Risk including Deductible
- Owner's Construction Contingency

Our estimate assumes there are no unusual sub-surface conditions such as, but not limited to:

- Boulders
- Ledge
- Ground Water
- Unsuitable or Contaminated Soils
- Inadequate Bearing

1 GENERAL CONDITIONS									
010 General & Special Conditions									
0101004	Overtime Premium						\$0	\$0	\$0
012 Field Supervision									
0101201	Superintendent \$95/hr	11	wks		\$3,800		\$41,800	\$0	\$41,800
0101202	Field engineer						\$0	\$0	\$0
014 Expenses									
0101401	Key Person Expenses	11	wks			\$0	\$25.00	\$275	\$275
016 Field Office									
0101601	Office Trailer Rental	3	mo			\$0	\$270.00	\$810	\$810
0101602	Move Trailers	2	ea			\$0	\$1,200.00	\$2,400	\$2,400
0101603	Storage trailer/shed	3	mo			\$0	\$200.00	\$600	\$600
0101604	Office supplies	3	mo			\$0	\$50.00	\$150	\$150
018 Safety Program									
0101801	First aid	1	ls			\$0	\$800.00	\$800	\$800
0101802	Owner Safety	1	ls			\$0	\$500.00	\$500	\$500
0101803	Safety Coordinator \$75/hr 2hr/wk	11	wks			\$0	\$150.00	\$1,650	\$1,650
0101805	Protective Equipment	1	ls			\$0	\$1,500.00	\$1,500	\$1,500



RRMC MRI Budget Estimate REV 8 04/27/21

Project: RRMC MRI Renovations
 Architect: Lavalley Brensinger

printed on 04/27/21

ITEM	DESCRIPTION	QUAN	U/M	UNIT LABOR	LABOR	UNIT MAT'L	MAT	SUB COST	TOTAL
0101807	Infect Control/Life Safety	11	wks		\$0	\$200.00	\$2,200		\$2,200
022 Tools									
0102202	Small Tools	11	wks		\$0	\$25.00	\$275		\$275
0102203	Equipment to Plant	3	mo		\$0	\$50.00	\$150		\$150
0102204	Rental, Company	TBD			\$0		\$0		\$0
0102205	Rental, Non-Company	3	mo		\$0	\$2,000.00	\$6,000		\$6,000
0102206	Pick-Up Trucks	3	mo		\$0	\$600.00	\$1,800		\$1,800
0102207	Company Gas	11	wks		\$0	\$100.00	\$1,100		\$1,100
0102208	Tool Repair	1	ls		\$0	\$1,500.00	\$1,500		\$1,500
0102209	Lifts for Trades				\$0		\$0		\$0
041 Project Management									
0104101	Senior Project Manager \$134.4 x 2 hrs p/wk	11	wks		\$0	\$268.80	\$2,957		\$2,957
0104102	Project Manager \$108 x 8 hrs p/wk	11	wks		\$0	\$864.00	\$9,504		\$9,504
0104103	Admin Travel Expense	11	wks		\$0	\$75.00	\$825		\$825
0104104	Executive Management	inc. in fee			\$0		\$0		\$0
0104105	Accounting	Fee	wks		\$0		\$0		\$0
0104106	Clerical	Fee	wks		\$0		\$0		\$0
0104107	Procore Subscription	PM	1	ls	\$0	\$1,000.00	\$1,000		\$1,000
042 Scheduling									
0104201	In House Scheduling	inc. in fee			\$0		\$0		\$0
0104202	Scheduling Consultant		ls		\$0		\$0		\$0
0104203	Maintain Schedules	inc. in fee			\$0		\$0		\$0
043 Preconstruction Services									
0104301	Fee	allow	1	ls	\$0	\$4,500.00	\$4,500		\$4,500
0104302	Reimbursables		1	ls	\$0	\$500.00	\$500		\$500
045 Insurances/Taxes									
0104501	State Sales Tax, EXEMPT		1	ls	\$0		\$0		\$0
0104503	Builders Risk		by owner		\$0		\$0		\$0
0104504	Owner Protective Liability		by owner		\$0		\$0		\$0
0104505	Bridge B.R. Deduct		ls		\$0		\$0		\$0
0104506	Other Insurance		ls		\$0		\$0		\$0
065 Permits									
0106502	Zoning/Local		1	ls	\$0	\$6,000.00	\$6,000		\$6,000
0106503	State /Fire Safety		1	ls	\$0	\$12,000.00	\$12,000		\$12,000
330 Survey & Layout									
0133003	Engineer Layout		1	ls	\$0		\$0		\$0
335 Protect/Repair Grounds									
0133504	Maintain Egress		1	ls	\$0	\$1,500.00	\$1,500		\$1,500
0133505	Temp Signage		1	ls	\$0	\$1,000.00	\$1,000		\$1,000
510 Temporary Utilities									
0151002	Temp Power Consump		by owner		\$0		\$0		\$0
0151003	Temp Lights & Wire		by subs		\$0		\$0		\$0
520 Winter Conditions									
0152001	Temp heat/fuel		assume none needed		\$0		\$0		\$0
0152002	Temp heat equipment		assume none needed		\$0		\$0		\$0
0152003	Winter weather shelter		assume none needed		\$0		\$0		\$0
0152004	Snow removal		assume none needed		\$0		\$0		\$0
525 Construction Aids									
0152507	Temp water		3	mo	\$0	\$75.00	\$225		\$225
0152508	Temp Toilets & Wash		3	mo	\$0	\$125.00	\$375		\$375
530 Barriers and Enclosures									
0153001	Temp Laydown area		1	ls	\$0	\$1,500	\$1,500		\$1,500
0153002	Temp fencing		50	lf	\$0	\$4.00	\$200		\$200
0153003	Temp Barricades		1	ls	\$0	\$500.00	\$500		\$500
540 Security									
0154001	Watchman				\$0		\$0		\$0
0154002	Security Systems				\$0		\$0		\$0
560 Quality Control/Testing									
0156001	Test Soils/Concrete	none	1	ls	\$0		\$0		\$0
0156002	Test Steel/Fire	none	1	ls	\$0		\$0		\$0
0156003	Assist with Testing	none			\$0		\$0		\$0
0156004	IBC Testing	none	1	ls	\$0		\$0		\$0
565 Temporary Fire Protection									
0156501	Temp fire extinguishers		1	ea	\$0	\$200.00	\$200		\$200
580 Project Identification									
0158001	Project Sign				\$0		\$0		\$0
660 Testing Systems									
0166001	Commissioning	none			\$0		\$0		\$0
0166002	Operational Testing				\$0		\$0		\$0
710 Cleaning									
0171001	Recycle Plan		1	ls	\$0		\$0		\$0
0171002	Dumpsters		3	mo	\$0	\$950.00	\$2,850		\$2,850
0171005	Progress Clean \$46.2 x 8 hrs p/wk		11	wks	\$369.60	\$4,066	\$0		\$4,066
0171007	Final Clean Building	1210	sf		\$0	\$1.25	\$1,513		\$1,513
720 Project Documents									
0172001	Document Print & Distrib		1	ls	\$0	\$500.00	\$500		\$500
0172002	Photos				\$0		\$0		\$0
0172003	As-Built Drawings		1	ls	\$0	\$500.00	\$500		\$500
0172004	Coordination Drawings				\$0		\$0		\$0
0172007	CAD Record Files				\$0		\$0		\$0
770 Project Closeout									
0177001	Warranties				\$0		\$0		\$0
0177002	O&M Manuals		1	ls	\$0	\$1,000.00	\$1,000		\$1,000
0177003	Closeout Expenses				\$0		\$0		\$0
800 LEED Objectives									



RRMC MRI Budget Estimate REV 8 04/27/21

Project: RRMC MRI Renovations
 Architect: Lavalley Brensinger

printed on 04/27/21

ITEM	DESCRIPTION	QUAN	U/M	UNIT LABOR	LABOR	UNIT MAT'L	MAT	SUB COST	TOTAL
0180001	General				\$0		\$0		\$0
810	Allowances								
0181001	General				\$0		\$0		\$0
820	Alternatives								
0182001	General				\$0		\$0		\$0
830	Owner Furnish								
0183001	General				\$0		\$0		\$0
840	Contractor Install								
0184001	General				\$0		\$0		\$0
850	Project Management								
0185001	Environmental Protection				\$0		\$0		\$0
0185002	Indoor Air Quality				\$0		\$0		\$0
0185003	Storm Water Control				\$0		\$0		\$0
0185004	Moisture & Mold Control				\$0		\$0		\$0
860	Supplemental GC's								
0186001	Punch List				\$0	\$2,500.00	\$0		\$0
0186002	Training				\$0		\$0		\$0
ITEM TOTAL					\$45,866		\$70,859	\$0	\$116,725

2 DEMOLITION & ALTERATIONS

ITEM	DESCRIPTION	QUAN	U/M	UNIT LABOR	LABOR	UNIT MAT'L	MAT	SUB COST	TOTAL
024100	Selective Demolition								
	Create opening to remove magnet	60	hr	\$62.30	\$3,738		\$0		\$3,738
	Interior Demo - Renovation/Add.				\$0		\$0		\$0
	Temp provisions	2	ea		\$0	\$3,000.00	\$6,000		\$6,000
	Mechanical/elect demo cut & patch	16	hrs	\$62.30	\$997	\$10.00	\$160		\$1,157
	Temp partitions	400	sf	\$10.00	\$4,000	\$3.00	\$1,200		\$5,200
	Rework existing	40	hr	\$62.30	\$2,492	\$10.00	\$400		\$2,892
	Walk-off mats	8	pads	\$31.15	\$249	\$80.00	\$640		\$889
	Negative air machines	11	wks	\$18.00	\$198	\$75.00	\$825		\$1,023
	Remove flooring	1210	sf	\$1.10	\$1,331	\$1.00	\$1,210		\$2,541
	Remove existing casework	25	lf	\$14.95	\$374		\$0		\$374
	Remove existing walls	29	lf	\$25.00	\$725		\$0		\$725
	Ceilings remove	675	sf	\$2.10	\$1,418	\$1.00	\$675		\$2,093
	HEPA filters	1	ls	\$250.00	\$250	\$1,000.00	\$1,000		\$1,250
	Carts	1	ea		\$0	\$400.00	\$400		\$400
	Pressure indicator	1	ea	\$200.00	\$200	\$750.00	\$750		\$950
	Dumpsters	1	ea		\$0	\$950.00	\$950		\$950
	Off hour work	50	hrs	\$31.15	\$1,558		\$0		\$1,558
					\$0		\$0		\$0
ITEM TOTAL					\$17,530		\$14,210	\$0	\$31,740

3 CONCRETE

033000	Cast-In-Place Concrete				\$0		\$0		\$0
	Extend existing exterior chiller pads	1	ls		\$0	\$3,500.00	\$3,500		\$3,500
					\$0		\$0		\$0
ITEM TOTAL					\$0		\$3,500	\$0	\$3,500

4 MASONRY

042000	Unit Masonry				\$0		\$0		\$0
	Subcontract Furnish & Install	None	1	Bid			\$0		\$0
	Assume existing masonry opening is large enough to allow removal of MRI unit				\$0		\$0		\$0
					\$0		\$0		\$0
ITEM TOTAL					\$0		\$0	\$0	\$0

5 METALS

051200	Structural Steel	none			\$0		\$0		\$0
054000	Cold-Formed Metal Framing	none			\$0		\$0		\$0
055000	Metal Fabrications	none			\$0		\$0		\$0
					\$0		\$0		\$0
ITEM TOTAL					\$0		\$0	\$0	\$0

6A ROUGH CARPENTRY

061053	Miscellaneous Carpentry				\$0		\$0		\$0
	Exterior blocking	none			\$0		\$0		\$0
	Interior blocking general	500	lf	\$2.50	\$1,250	\$2.50	\$1,250		\$2,500
					\$0		\$0		\$0
ITEM TOTAL					\$1,250		\$1,250	\$0	\$2,500

6B FINISH CARPENTRY & MILLWORK

062000	Finish Carpentry & Architectural Woodwo	SEE 123600			\$0		\$0		\$0
					\$0		\$0		\$0
ITEM TOTAL					\$0		\$0	\$0	\$0



RRMC MRI Budget Estimate REV 8 04/27/21

Project: RRMC MRI Renovations
 Architect: Lavalley Brensinger

printed on 04/27/21

ITEM	DESCRIPTION	QUAN	U/M	UNIT LABOR	LABOR	UNIT MAT'L	MAT	SUB COST	TOTAL
7 THERMAL & MOISTURE PROTECTION									
071113	Bituminous Damp-proofing				\$0		\$0		\$0
	not required								
072100	Thermal Insulation at Exterior Wall				\$0		\$0		\$0
	refer to 072415				\$0		\$0		\$0
072110	Acoustic Insulation				\$0		\$0		\$0
	Thermafiber - interior partitions	1700	sf		\$0		\$0		\$0
	R-21 - exterior wall	100	sf	\$1.25	\$125	\$2.00	\$200		\$325
072415	EIFS				\$0		\$0		\$0
	Patch existing	100	sf		\$0	\$50.00	\$5,000		\$5,000
072500	Weather Barriers				\$0		\$0		\$0
	Patch in at existing wall patch	100	sf		\$0	\$10.00	\$1,000		\$1,000
075300	Elastomeric Membrane Roofing				\$0		\$0		\$0
	Patch at existing	1	ls		\$0	\$5,000.00	\$5,000		\$5,000
076200	Sheet Metal Flashing & Trim				\$0		\$0		\$0
	Aluminum flashing @ roof to wall tie in	88	lf		\$0	\$15.00	\$1,320		\$1,320
	Continue drip groove	97	lf		\$0		\$0		\$0
	Drip Edge	97	lf		\$0		\$0		\$0
077200	Roof Accessories				\$0		\$0		\$0
	Subcontract Furnish & Install			none	\$0		\$0		\$0
078110	Sprayed Fire-Resistive Materials				\$0		\$0		\$0
	Patch Existing	1	ls		\$0	\$1,200.00	\$1,200		\$1,200
078413	Fire-stopping				\$0		\$0		\$0
	Misc not by trades	1	ls	\$300.00	\$300	\$300.00	\$300		\$600
079200	Joint Sealers				\$0		\$0		\$0
	Interior Joint	1	ls	\$250.00	\$250	\$150.00	\$150		\$400
	Exterior Joint	50	lf		\$0	\$4.00	\$200		\$200
ITEM TOTAL					\$675		\$14,370	\$0	\$15,045

8 DOORS, WINDOWS & GLASS									
081100	Steel Door Frames				\$0		\$0		\$0
	Door Supplier	1	Bid		\$0		\$0		\$0
	Unload, sort, store & protect		ls		\$0		\$0		\$0
	F1 3'-0" x 7'-0"	3	ea	\$125.00	\$375	\$800.00	\$2,400		\$2,775
	F2 6'-0" x 7'-0"	1	ea	\$125.00	\$125	\$1,200.00	\$1,200		\$1,325
082110	Flush Wood Doors				\$0		\$0		\$0
	D1 3'-0" x 7'-0"	5	ea	\$174.00	\$870	\$800.00	\$4,000		\$4,870
083100	Access Doors & Frames				\$0		\$0		\$0
	18 x 18" clg access	3	ea	\$100.00	\$300	\$200.00	\$600		\$900
084115	Exterior Thermally-Broken Aluminum Windows				\$0		\$0		\$0
	Replace existing round window	12	sf		\$0	\$625.00	\$7,500		\$7,500
084300	Interior sliding glass partition				\$0		\$0		\$0
	Sliding glass wall	184	sf		\$0	\$100.00	\$18,400		\$18,400
087100	Door Hardware				\$0		\$0		\$0
	Door Openings (leaves)	5	ea	\$174.00	\$870	\$350.00	\$1,750		\$2,620
	Access control - rework existing	1	ls		\$0	\$6,000.00	\$6,000		\$6,000
	Power swing operators replace existing	2	ea		\$0	\$3,400.00	\$6,800		\$6,800
088000	Glazing				\$0		\$0		\$0
	Glazing Sub				\$0		\$0		\$0
	Interior door glazing	8	sf		\$0	\$35.00	\$280		\$280
ITEM TOTAL					\$2,540		\$48,930	\$0	\$51,470

9 FINISHES									
090561	Common Work Results For Flooring Preparation				\$0		\$0		\$0
	Floor moisture & Ph testing	1210	sf		\$0		\$0		\$0
	Prep existing floor for new	1210	sf		\$0		\$0		\$0
	Moisture mitigation	allow	1210	sf	\$0	\$6.00	\$7,260		\$7,260
092600	Gypsum Board Assemblies				\$0		\$0		\$0
	Gypsum Assemblies Sub				\$0		\$0		\$0
	Exterior Wall System infill existing		sf		\$0		\$0		\$0
	2" Rigid cavity insulation	150	sf		\$0	\$3.00	\$450		\$450
	5/8" exterior GWB	150	sf		\$0	\$2.25	\$338		\$338
	Framing	150	sf		\$0	\$6.50	\$975		\$975
	5 1/2" R-21	150	sf		\$0	\$1.00	\$150		\$150
	6 mil poly vapor barrier	150	sf		\$0	\$0.50	\$75		\$75
	5/8" Gyp wallboard	150	sf		\$0	\$2.25	\$338		\$338
	Partition	64	sf		\$0	\$15.00	\$960		\$960
	New closet walls	100	sf		\$0	\$25.00	\$2,500		\$2,500



RRMC MRI Budget Estimate REV 8 04/27/21

Project: RRMC MRI Renovations
 Architect: Lavalley Brensinger

printed on 04/27/21

ITEM	DESCRIPTION	QUAN	U/M	UNIT LABOR	LABOR	UNIT MAT'L	MAT	SUB COST	TOTAL
	New Changing area walls	400	sf		\$0	\$15.00	\$6,000		\$6,000
	Replace interior exterior wall for magnet removal	150	sf		\$0	\$15.00	\$2,250		\$2,250
	Rework soffit for sliders	28	lf		\$0	\$100.00	\$2,800		\$2,800
	New soffit for utilities	85	sf		\$0	\$100.00	\$8,500		\$8,500
	Patching at existing	1	ls		\$0	\$2,500.00	\$2,500		\$2,500
	Remove and replace drywall	200	sf		\$0	\$3.00	\$600		\$600
					\$0		\$0		\$0
	095100 Acoustical Ceilings				\$0		\$0		\$0
	Ceilings Sub				\$0		\$0		\$0
	ACT-1 2x2 Armstrong	675	sf		\$0	\$10.00	\$6,750		\$6,750
					\$0		\$0		\$0
	096500 Resilient Flooring				\$0		\$0		\$0
	Flooring Sub				\$0		\$0		\$0
	LVT	675	sf		\$0	\$12.00	\$8,100		\$8,100
	LVT static guard at magnet room	535	sf		\$0	\$14.00	\$7,490		\$7,490
	Protect floors	1210	sf		\$0	\$1.50	\$1,815		\$1,815
	Floor prep	1210	sf	\$0.75	\$908	\$0.75	\$908		\$1,816
	Patch existing floor	1	ls	\$250.00	\$250	\$200.00	\$200		\$450
	Protect existing flooring to remain	200	sf	\$1.00	\$200	\$1.00	\$200		\$400
					\$0		\$0		\$0
	097100 Access Floor	none			\$0		\$0		\$0
					\$0		\$0		\$0
	097500 Acoustic Roof Components	none			\$0		\$0		\$0
					\$0		\$0		\$0
	096800 Carpeting	refer to 096500			\$0		\$0		\$0
					\$0		\$0		\$0
	099123 Painting and Coating				\$0		\$0		\$0
	Painting Sub				\$0		\$0		\$0
	Interior painting (Per Finish Schedule)	1210	sf		\$0	\$4.00	\$4,840		\$4,840
	Artist painting on MRI room ceiling, labor	80	hrs	\$70.00	\$5,600		\$0		\$5,600
	Artist painting on MRI room ceiling, material	1	ls		\$0	\$1,500.00	\$1,500		\$1,500
	Staging for artist	1	ls		\$0	\$800.00	\$800		\$800
					\$0		\$0		\$0
	ITEM TOTAL				\$6,958		\$68,299	\$0	\$75,257

10 SPECIALTIES

	101425 Code Required Building Signage	by owner			\$0		\$0		\$0
					\$0		\$0		\$0
	102123 Cubicles	none			\$0		\$0		\$0
					\$0		\$0		\$0
	102600 Wall & Corner Protection				\$0		\$0		\$0
	Wall Protection Sub				\$0		\$0		\$0
	IRPP on Walls	272	sf		\$0	\$8.00	\$2,176		\$2,176
	Corner guard 4'	5	ea		\$0		\$0		\$0
					\$0		\$0		\$0
	108010 Toilet & Healthcare Accessories	none			\$0		\$0		\$0
					\$0		\$0		\$0
	104413 Fire Protection Specialties				\$0		\$0		\$0
	Fire Extinguisher cab & ext	re-use existing			\$0		\$0		\$0
					\$0		\$0		\$0
	ITEM TOTAL				\$0		\$2,176	\$0	\$2,176

11 EQUIPMENT

	117713 MRI Ferromagnetic Detection System	existing to remain			\$0		\$0		\$0
					\$0		\$0		\$0
	ITEM TOTAL				\$0		\$0	\$0	\$0

12 FURNISHINGS

	123600 Casework & Counter-tops				\$0		\$0		\$0
	Casework Sub				\$0		\$0		\$0
	Cabinet/hamper in Changing	1	ea		\$0		\$0		\$0
	Control Room				\$0		\$0		\$0
	SS Counter-top for GE item #27	9	sf	\$35.00	\$315	\$210.00	\$1,890		\$2,205
	Equipment room				\$0		\$0		\$0
	Shelf for GE item #31	1	ea	\$30.00	\$30	\$150.00	\$150		\$180
	MRI room				\$0		\$0		\$0
	Base cabinet	12	lf	\$35.00	\$420	\$400.00	\$4,800		\$5,220
	Wall cabinet	6	lf	\$35.00	\$210	\$375.00	\$2,250		\$2,460
	SS Counter-top	24	sf	\$35.00	\$840	\$200.00	\$4,800		\$5,640
	Misc. Millwork	1	ls	\$500.00	\$500	\$525.00	\$525		\$1,025
					\$0		\$0		\$0
	ITEM TOTAL				\$2,315		\$14,415	\$0	\$16,730

13 SPECIAL CONSTRUCTION

	134700 MRI Support				\$0		\$0		\$0
	Install vibroacoustic dampening kit, GE item #	OFCI	4	ea	\$249.20	\$997	\$0		\$997
	Install magnet curtain kit, GE item #2	OFCI	1	ea	\$373.80	\$374	\$0		\$374
	Patient table dock anchoring	allow	1	ea	\$186.90	\$187	\$150	\$150	\$337
					\$0		\$0		\$0
	134713 Temp MRI Pad				\$0		\$0		\$0
	Existing Concrete pad to be reused				\$0		\$0		\$0
	Temp awning in place to be reused, allow to a	allow	1	ls	\$0	\$4,000	\$4,000		\$4,000
	Remove existing awning when complete	allow	1	ls	\$0	\$4,000	\$4,000		\$4,000
					\$0		\$0		\$0
	134941 RF Shielding				\$0		\$0		\$0



RRMC MRI Budget Estimate REV 8 04/27/21

Project: RRMC MRI Renovations
 Architect: Lavalley Brensinger

printed on 04/27/21

ITEM	DESCRIPTION	QUAN	U/M	UNIT LABOR	LABOR	UNIT MAT'L	MAT	SUB COST	TOTAL	
Shielding Sub										
	RF enclosure rework			1	budget		\$0	\$29,200	\$29,200	
	New filters and testing						\$0		\$0	
	Allow to repair existing						\$0		\$0	
	HVAC Wave Guides	1	ea			\$8,000	\$8,000		\$8,000	
	Plumbing Wave Guides	0	ea				\$0		\$0	
	RF Electrical Filters	0	ea				\$0		\$0	
	RF Testing Services	0	sf				\$0		\$0	
	Mag shield enclosure plywood	0	sf				\$0		\$0	
							\$0		\$0	
ITEM TOTAL							\$1,558	\$16,150	\$29,200	\$46,908
14 CONVEYING SYSTEMS										
	not used			none			\$0	\$0	\$0	
							\$0		\$0	
ITEM TOTAL							\$0	\$0	\$0	\$0
21 FIRE SUPPRESSION										
210000 Fire Protection										
Fire Protection Sub										
	Rework existing	1210	sf			\$5.00	\$6,050		\$6,050	
	Pre-action system			1	ls		\$0		\$0	
							\$0		\$0	
ITEM TOTAL							\$0	\$6,050	\$0	\$6,050
22 PLUMBING										
220000 Plumbing										
Plumbing Sub										
	Rework existing city water back up system	30	hrs	\$80.00	\$2,400	\$15	\$450		\$2,850	
	Med gas outlets, O.V.A.S	0	ea		\$0		\$0		\$0	
	Water for equipment room	0	ls		\$0		\$0		\$0	
	Water for Chiller	0	ls		\$0		\$0		\$0	
	Water to temp MRI	0	lf		\$0		\$0		\$0	
					\$0		\$0		\$0	
ITEM TOTAL							\$2,400	\$450	\$0	\$2,850
23 HEATING, VENTILATING, AND AIR-CONDITIONING (HVAC)										
230000 HVAC										
Mechanical Sub										
	New VAV at Changing			1	budget		\$0	\$184,500	\$184,500	
	New return VAVs						\$0		\$0	
	New 3" Chilled water lines from south mech rm						\$0		\$0	
	Valves						\$0		\$0	
	Remove existing Computer room chiller replace with new provided by owner						\$0		\$0	
	Remove existing MRI chiller replace with new provided by owner						\$0		\$0	
	Hoist						\$0		\$0	
	Rework Quench vent						\$0		\$0	
	TAB						\$0		\$0	
	HVAC Controls						\$0		\$0	
	Temporary provisions						\$0		\$0	
	Unforeseen conditions	allow		1	ls		\$8,000	\$8,000	\$8,000	
							\$0		\$0	
	MRI AHU (existing to remain)						\$0		\$0	
	MRI SA VAV's (existing to remain)						\$0		\$0	
	AC Split Units at computer room (existing to remain)						\$0		\$0	
							\$0		\$0	
ITEM TOTAL							\$0	\$8,000	\$184,500	\$192,500
25 INTEGRATED AUTOMATION										
250000 HVAC Instrumentation and Controls										
	refer to 230000						\$0	\$0	\$0	
							\$0		\$0	
ITEM TOTAL							\$0	\$0	\$0	\$0
26 ELECTRICAL										
260000 Electrical										
Electrical Sub										
	New electrical			1	budget		\$0	\$125,290	\$125,290	
	Temporary provisions			1210	sf		\$0		\$0	
	Ceiling scene lighting			1	ls		\$0		\$0	
	Cable ladder			1	ls	\$25,000.00	\$25,000		\$25,000	
	Temporary MRI Trailer Support (lights & power)			68	lf	\$26.00	\$1,768		\$1,768	
	Unforeseen conditions	allow		1	ls	\$5,000.00	\$5,000		\$5,000	
				1	ls	\$2,500	\$2,500		\$2,500	
							\$0		\$0	
ITEM TOTAL							\$0	\$34,268	\$125,290	\$159,558



RRMC MRI Budget Estimate REV 8 04/27/21

Project: RRMC MRI Renovations
 Architect: Lavalley Brensinger

printed on 04/27/21

ITEM	DESCRIPTION	QUAN	U/M	UNIT LABOR	LABOR	UNIT MAT'L	MAT	SUB COST	TOTAL
27 COMMUNICATIONS									
270000	Communications				\$0		\$0		\$0
	Subcontract Furnish & Install				\$0		\$0		\$0
	New data/Phone			refer to 260000	\$0		\$0		\$0
	Nurse call			refer to 260000	\$0		\$0		\$0
					\$0		\$0		\$0
	ITEM TOTAL				\$0		\$0	\$0	\$0
28 ELECTRONIC SAFETY & SECURITY									
283100	Fire Detection and Alarm				\$0		\$0		\$0
	Rework existing			refer to 260000	\$0		\$0		\$0
		1210	sf		\$0		\$0		\$0
					\$0		\$0		\$0
	ITEM TOTAL				\$0		\$0	\$0	\$0
31 EARTHWORK									
310000	Earthwork				\$0		\$0		\$0
	Earthwork Sub				\$0		\$0		\$0
	Extend chiller pad			1	\$0	\$2,800.00	\$2,800		\$2,800
					\$0		\$0		\$0
	ITEM TOTAL				\$0	\$2,800	\$0	\$0	\$2,800
32 EXTERIOR IMPROVEMENTS									
320000	Exterior Improvements				\$0		\$0		\$0
	Landscaping			repair	\$0	\$1,600.00	\$1,600		\$1,600
		1	ls		\$0		\$0		\$0
					\$0		\$0		\$0
	ITEM TOTAL				\$0	\$1,600	\$0	\$0	\$1,600
33 UTILITIES									
330000	Utilities				\$0		\$0		\$0
				none	\$0		\$0		\$0
					\$0		\$0		\$0
	ITEM TOTAL				\$0		\$0	\$0	\$0



January 21, 2019

Joe Britton
Lavallee Brensinger Architects
155 Dow Street
Manchester, NH 03101

Rutland Regional Medical Center – MRI Renovation MEP Narrative

L.N. Consulting, Inc. has been retained by Rutland Regional Medical Center to provide a MEP narrative for the renovation of the existing MRI suite at Rutland Regional Medical Center located in Rutland, Vermont.

Mechanical:

The existing MRI Suite is primarily conditioned via a 4,220 CFM air handling unit located in the ground floor MRI mechanical room. The unit provides air through (3) supply air variable air volume boxes with hot water re-heat coils which provide air to the MRI machine room, holding room, and control room. The existing MRI air handling unit is supported by a 20 ton chiller located outside to the south of the MRI Suite. The existing MRI computer room is conditioned via a dedicated chiller and (2) 6 ton computer room air conditioned units.

The existing air handling unit shall be reused. (1) new supply variable air volume boxes with hot water reheat coil shall be provided to support the new changing room. The changing room temperature control zone shall be sized for 250 CFM. (3) New return air VAV's shall be provided for each temperature control zone. The MRI air handling unit and associated pumps, terminal units, and sensors shall be upgraded to current direct digital control technology.

Provide new set of 3" chilled water lines from the existing 6" chilled water mains located in the southern mechanical room. The new chilled water lines shall tie into the existing MRI air handling unit chilled water loop and shall be provided with isolation valves in order to allow for switchover between the MRI air handling unit chiller and the central chilled water plant.

The existing MRI computer room chiller shall be demolished and provided with the new GE provided chiller. Expand equipment pad at exterior to accommodate new chiller. Existing 2" chilled water lines shall be reused. The existing city water back-up system shall be reused. Tie the existing 2" chilled water lines into heat exchanger cabinet. Provide direct digital controls interconnection into GE provided chiller.

**Electrical:**

The existing electrical service supporting the MRI is fed from the Normal Power Substation SS103 located in the North Electrical Room. The design documents indicate that the existing MRI main disconnect switch is fed from 200A fuses from Substation SS103 with (3) 4/0 Conductors, (1) #4/0 Neutral, and (1) #4/0 Ground in a 2 1/2" Conduit. Conductors and fuses shall be verified in the field. If they are consistent with sizes indicated above, then the existing power feed for the new MRI can be re-used. The 200A main distribution breaker shall feed a new 150A-3P breaker supporting the PDU circuit and a new 50A-3P breaker supporting the HEC circuit. (2) EPO buttons shall be provided to disable MDP circuit.

Provide 480V-3P-30A emergency power circuit to Cryrogen Compressor. Provide 120V-20A emergency power circuit to Magnon3.

The new MRI chiller shall be fed from a new 80A-3P breaker in Panel H166 located in the MRI mechanical room. Contractor shall provide 3/4" conduit with pull string from new chiller location to MRI operators work station.

Provide power, conduit, cabling, and cable tray as required per GE MRI equipment drawings.

Provide (1) patient pull cord within changing room and (1) nurse call dome light outside of changing room. Provide general receptacle within changing room. Provide fire alarm strobe within changing room.

All lighting in renovated areas shall be replaced with new LED light fixtures and controls.

Please let us know if you have any questions or comments.

Sincerely,

L.N. Consulting, Inc.

George D. Martin III, P.E.

June 29, 2021

Jim Greenough, VP Corporate Support Services

Rutland Regional Medical Center

160nAllen Street, Rutland, VT 05701

Re: Rutland Regional Medical Center – Replacement MRI

Dear Jim,

Regarding the renovations to the existing MRI vault and associated support spaces as related to the replacement of the MRI equipment, all renovations will be in accordance with the 2018 edition of the Guidelines for the Design and Construction of Hospitals, FGI section 2.2-3.4.5 Magnetic Resonance Imaging (MRI) Facilities.

Below is a general description of the project, the replacement equipment, and architectural improvements to the existing space. Attached to this document is a January 21, 2019, infrastructure narrative from LN Engineering. Like the architectural narrative, the MEP provides description of intended infrastructure improvements necessary to support the new MRI equipment.

General Building Information and Project Description

1. **Location:** Rutland Vermont, on the campus of Rutland Regional Medical Center.
2. **Building Type:** I2, Hospital, FGI 2018, (AIA, Guidelines for Construction and Equipment of Hospitals and Medical Facilities)
3. **Existing Building Description:** Existing one-story portion of the Rutland Regional Medical Center.
 - a. Located on the South side of the hospital, the MRI suite is a partial slab on grade. The Magnet vault is slab on grade with mechanical support located in a basement area beneath the equipment room. The existing exterior brick and EFIS system will remain without change and there are no changes to the roof system expected.
4. **Project description:**
 - a. The existing MRI suite is 1,070 gsf consisting of a 475-sf imaging vault (Safety Zone 4), a 156 sf Control Room and 151 Patient Holding area (safety zone 3), and a 165 sf equipment room.

- b. Patients enter from a public corridor (safety zone 1) directly into the Patient Holding area (safety zone 3) with access control and ferromagnetic detection at the corridor door. There currently is no distinct Patients Safety Zone 2.
- c. The project includes the following;
 - i. Replacing the existing 1.5T MRI with a new 1.5T MRI.
 - ii. Interior vault upgrades to accommodate the new MRI.
 - iii. Interior renovations to the equipment room to accommodate the new support equipment for the MRI.
 - iv. Cosmetic renovations to the Control room and Patient Holding area.
 - v. Renovations to approximately 160 sf to create new ADA compliant Patient Changing booths and interview area (patient safety zone 2) with access directly off the public corridor (patient safety zone 1).

5. Building Systems, Components and Materials:

- a. Building Structure
 - i. The project does not include any expansion or modification to the existing building structure.
- b. Architecture
 - i. Exterior envelope;
 - 1. The project does not include any expansion or modification to the existing exterior envelope.
 - ii. Interior renovations;
 - 1. Walls in the new Patient Safety Zone 2 will be S-11, 3 5/8" metal studs, acoustical insulation full height, 1-layer 5/8" GWB per side, all walls are full height deck to deck.
 - 2. Doors will be solid core, natural finish hard wood. Frames to be hollow metal welded. Hardware to be heavy duty mortise lock and latch sets. Door sizes will be 3'0x7'0 for non-patient access spaces and 3'6x7'0 for all spaces to meet ADA access.
 - 3. Floor finishes to vinyl sheet, plank or tile products in Zones 1,2,3 and 4 and the equipment room.
 - 4. Wall finishes in general will be paint with some vinyl wall protection on all walls, up to 4 feet from the top of wall base.
 - 5. Ceilings in finished rooms will be typically 2x2 acoustical ceilings with 15/16 grid. Unfinished spaces such as the Equipment Room may not have a finished ceiling. The MRI vault ceiling will remain as is with minor alterations to accommodate venting changes.
 - 6. All millwork will be custom built with plastic laminate finishes and vinyl edges.
 - 7. Ferromagnetic detection and warning systems will be installed at the door between Patient Safety Zones 2 and 3, 3 and 4, as well as zones 1 and 3 (the in-patient access).

June 2021
Lavallee Brensinger Architects

Page 3 of 3

A handwritten signature in black ink, appearing to read 'JFBAA', written in a cursive style.

Joseph F. Britton RA., Vice President
Lavallee Brensinger Architects

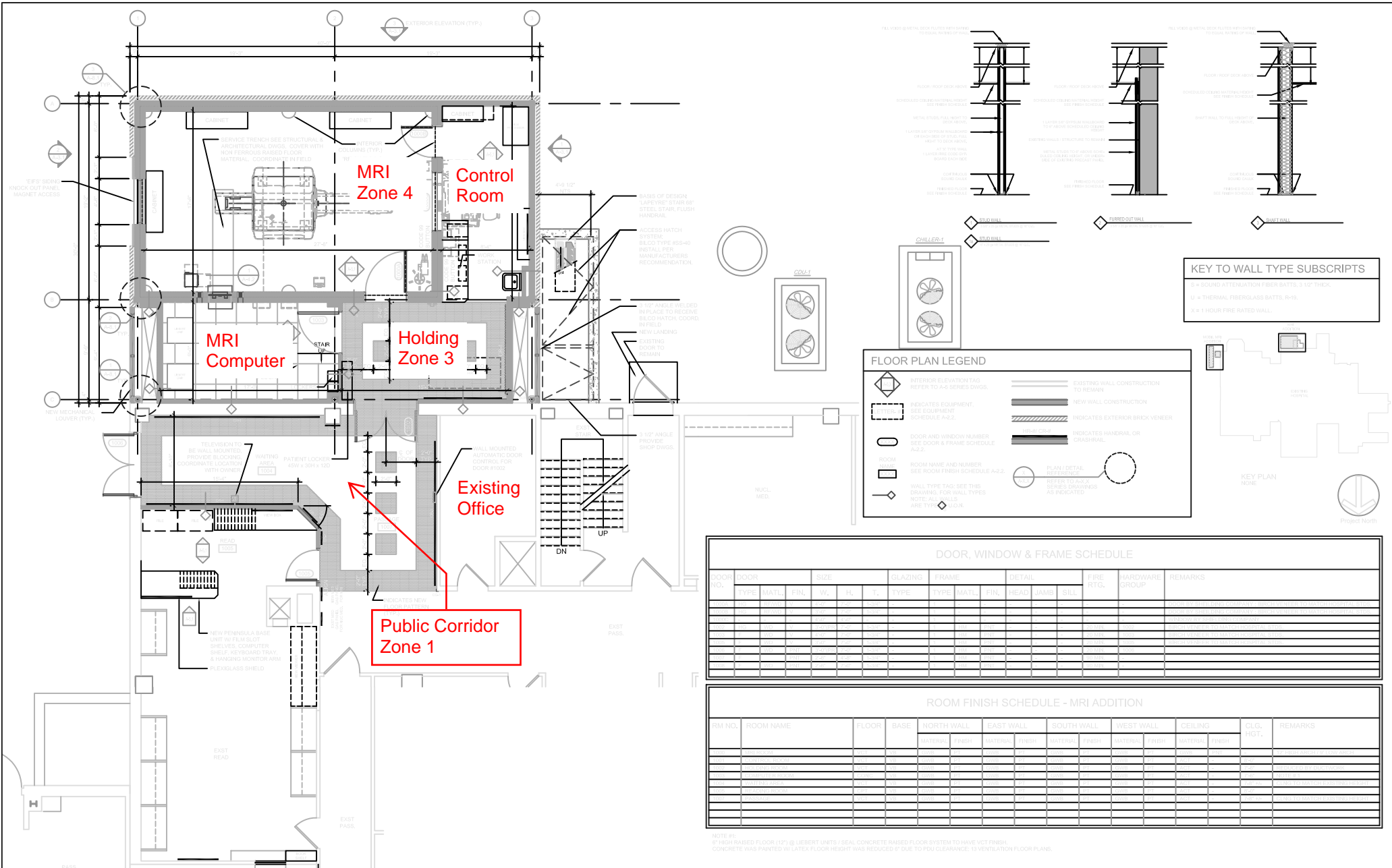

DOOR NO.	DOOR TYPE	GLAZING	FRAME	DETAIL	FIRE RTG.	HARDWARE GROUP	REMARKS

RM NO.	ROOM NAME	FLOOR	BASE	WALLS			CEILING	CLG. MGT.	REMARKS
				NORTH WALL	EAST WALL	SOUTH WALL			

NOTE #1: IF HIGH RAISED FLOOR (HRT) @ LIBERTY UNITS, SEAL CONCRETE RAISED FLOOR SYSTEM TO HAVE VOT FINISH. CONCRETE WAS PAINTED W/ LATEX. FLOOR HEIGHT WAS REDUCED BY DUE TO PDU CLEARANCE. 15 VENTILATION FLOOR PLANS.

Date	Revision	Date	Revision

RECORD DRAWINGS
MAY 2001

MORRIS/SWITZER ASSOCIATES INC.

ARCHITECTURE INTERIOR DESIGN PLANNING

147 Zouf Road, Suite 100
Rutland, VT 05701
Tel: 248-8441 Fax: 248-5350

Date: 2003
Drawn: CCS
Project Name: MRI ADDITION (Existing Conditions)
Sheet Number: A-2.2

Scale: 1/4" = 1'-0"

Project Location: RUTLAND, VERMONT

FIRST FLOOR NEW CONSTRUCTION PLAN



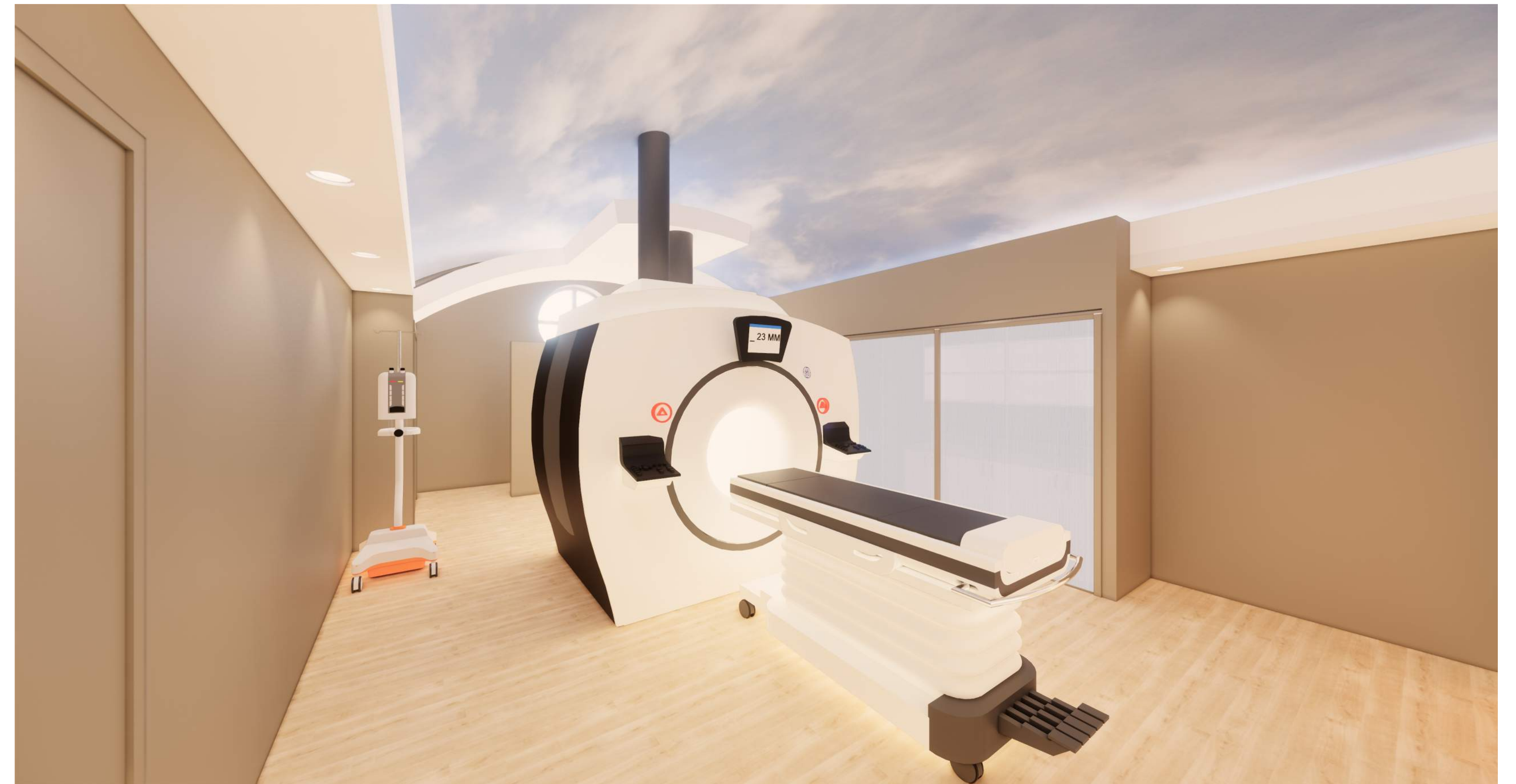
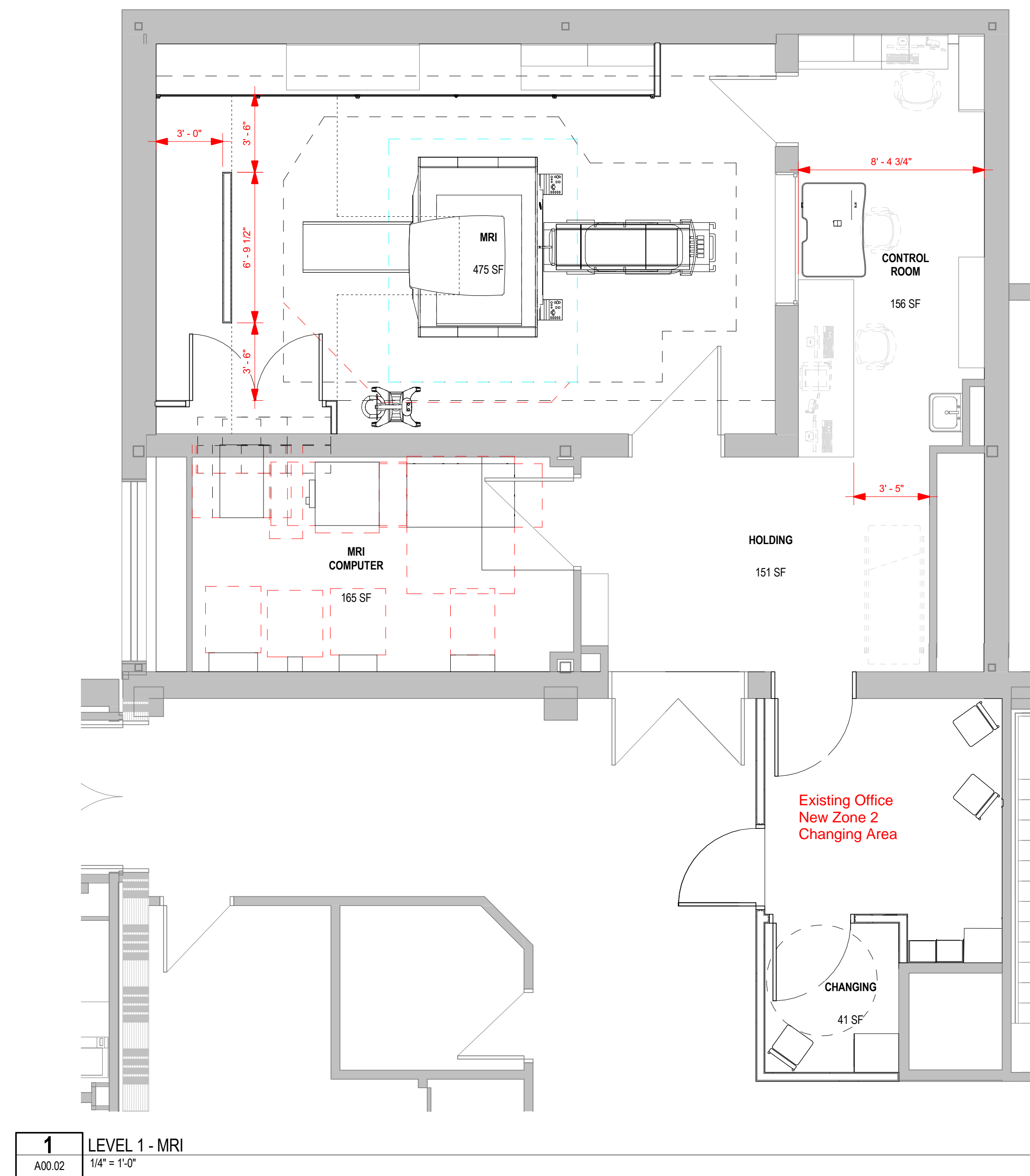

Memo

To: Jim Greenough, VP Corporate Support Services

From: David Adams

Date: October 29, 2020

Re: Rutland Regional Medical Center – MRI Renovation

This memo confirms that Efficiency Vermont is working closely with RRMC on the development and implementation of the MRI Renovation at their Rutland facility.

As part of the project team, Efficiency Vermont has assigned a designated energy consultant, who will provide support services as part of the design process, including:

- Technical assistance & recommendations on energy efficiency opportunities
- Cost/benefit analysis of options
- Collaborate with Architects/Contractors
- Provide “Objective Expertise”
- Financial incentives & assistance

The collaborative goal of these efforts is to achieve the highest levels of efficiency that are appropriate for a project of this nature, and in the process, reduce energy costs, strengthen the economy, and protect our environment.

If you have any questions, don't hesitate to contact me directly.

Thanks,

David C. Adams, BEP

Senior Account Manager

Efficiency Vermont

P: (802) 540-7628

C: (802) 318-7561



Quotation

Quote produced for:

Shari Patch, Director of Radiology
 Rutland Regional Medical Center
 160 Allen Street
 Rutland, VT 05701

Quote no. 00188
Quote date 04-Sep-20
Valid until 04-Sep-21

Description of Service	Amount
Physicist survey of new MRI scanner	\$2,200
TOTAL:	\$2,200

Comments

1. Cardinal Medical Physics Services, LLC will maintain minimum liability insurance of 1 million.
2. Cardinal Medical Physics Services, LLC will maintain current calibration certificates on all equipment.
3. Arthur J. Savard will maintain MQSA credentials and State registration.

CUSTOM IMAGING SOLUTIONS for: Rutland Regional Medical Center



Rutland, VT

June 18, 2021

Prepared for: Shari Patch

**Prepared by: Tracee Riley
Alliance HealthCare Radiology
triley@allianceradiology-us.com
603-785-3663**

Description of Service

Rutland Regional Medical Center is in need of interim MRI services for no less than six (6) months. The replacement of the existing MRI system will determine the length of stay needed for the interim unit. Alliance Radiology is sensitive to the needs of Rutland Regional Medical Center and will make every effort to work within the timelines of the facility.

- Alliance shall be responsible for the maintenance, upkeep and repair of the MRI equipment and trailer during this agreement.
- Rutland Regional Medical Center will be responsible for the cost of site preparation, including the provision of a dedicated electrical power (480 V three phase) for the interim rental MRI unit. Alliance will assist in assessing the site and in determining the specific pad and power needs of the site.
- Rutland Regional Medical Center will provide all supplies and materials used in performance of MRI procedures.
- Rutland Regional Medical Center will provide a qualified technologist to operate the MRI scanner.
- Rutland Regional Medical Center will have full responsibility for all medical care and advice provided to patients.

Recommendation

Alliance proposes to provide a mobile GE MRI system, unstaffed on a flat monthly basis, appropriately prorated for any partial months of service beyond one month:

GE 16 Ch. HDxT 23.0 (unstaffed):	\$32,000
GE Voyager 26.0 (unstaffed):	\$45,000
Acclimations Training TBD:	
Day 1:	\$1,800
Day 2:	\$1,600
Day 3 and thereafter:	\$1,200
Transportation fee \$4.00 per mile not to exceed \$3,500:	TBD*
Cleaning fee:	\$500**

* Transportation costs vary subject to location, availability and receipt of signed contract. Transportation costs will be determined based on the nearest available equipment to the facility that meets client's need.

**Cleaning fee will be refunded if unit is found to be in a comparable condition to when it was delivered.

**This proposal contains approximate quotes based on currently available equipment in the market or in-fleet at Alliance Radiology.*

Next Steps

Commitment and Acceptance: This proposal is subject to execution of a mutually acceptable agreement. This proposal is for informational purposes only and is not a binding legal obligation. This proposal is good for 60 days from receipt. Terms and conditions are subject to change after this 60-day timeframe. All units are quoted subject to availability.

To proceed with this proposal, please contact Tracee Riley at (603) 785-3663 or triley@allianceradiology-us.com to request an agreement for interim services.



Rutland Regional Medical Center
 160 Allen St
 Rutland, VT 05701-4560

This Agreement (as defined below) is by and between the Customer and the GE Healthcare business (“GE Healthcare”), each as identified below for the sale and purchase of the Products and/or Services identified in this Quotation, together with any applicable schedules referred to herein (“Quotation”). “Agreement” is this Quotation and either: (i) the Governing Agreement identified below; or (ii) if no Governing Agreement is identified, the GE Healthcare Terms and Conditions and Warranties that apply to the Products and/or Services identified in this Quotation. In the event of conflict, the Quotation supersedes.

GE Healthcare can withdraw this Quotation at any time before Customer: (i) signs and returns this Quotation or (ii) provides evidence of Quotation acceptance satisfactory to GE Healthcare (“Quotation Acceptance”). On Quotation Acceptance, this Agreement is the complete and final agreement of the parties relating to the Products and/or Services identified in this Quotation. There is no reliance on any terms other than those expressly stated or incorporated by reference in this Agreement and, except as permitted in this Agreement, no attempt to modify will be binding unless agreed to in writing by the parties. Modifications may result in additional fees and cannot be made without GE Healthcare’s prior written consent.

Handwritten or electronic modifications on this Agreement (except an indication of the form of payment, Customer purchase order number and signatures on the signature blocks below) are void.

Governing Agreement:	Novation Vizient Supply LLC
Terms of Delivery	FOB Destination
Billing Terms	80% on Delivery / 20% on Acceptance
Payment Terms	45 Net
Total Quote Net Selling Price	\$61,917.26
Sales and Use Tax Exemption	Certificate on File

IMPORTANT CUSTOMER ACTIONS:

Please select your planned source of funds. Source of funds is assumed to be cash unless you choose another option. Once equipment has been shipped, source of funds changes cannot be allowed.

- Cash
- GE HFS Loan GE HFS Lease
- Other Financing Loan Other Financing Lease Provide Finance Company Name _____

The parties have caused this Agreement to be executed by their authorized representative as of the last signature date below.

Rutland Regional Medical Center

Signature: _____

Print Name: _____

Title: _____

Date: _____

Purchase Order Number, if applicable

GE Precision Healthcare LLC, a GE Healthcare business

Signature: Edwina Ashe

Title: Imaging Account Manager

Date: June 15, 2021

To Accept This Quotation

Please sign and return this quotation together with your Purchase Order to:

Name: Edwina Ashe
Email edwina.ashe@ge.com
Phone: (351) 209-0771
Fax:

Payment Instructions

Please **remit** payment for invoices associated with this quotation to:

GE Precision Healthcare LLC
P.O. Box 96483
Chicago, IL 60693

FEIN: 83-0849145

Rutland Regional Medical Center**Addresses:**

Bill To: RUTLAND REGIONAL MEDICAL CENTER

RUTLAND REGIONAL MEDICAL, CENTER 160 ALLEN ST
RUTLAND, VT, 05701-4560

Ship To: RUTLAND REGIONAL MEDICAL CENTER

CENTER 160 ALLEN ST RUTLAND, VT, 05701-4560

To Accept This Quotation

- Please sign the quote and any included attachments (where requested).
- If requested, please indicate your form of payment.
- If you include a purchase order, please make sure it references the following information:
The correct Quote number and Version number above
The correct Remit To information as indicated in **“Payment Instructions”** above
Your correct SHIP TO and BILL TO site name and address
The correct Total Price as indicated above

Upon submission of a purchase order in response to this quotation, GE Healthcare requests the following to evidence agreement to contract terms: Signature page on quote filled out with signature and P.O. number **** OR**** Verbiage on the purchase order must state one of the following:

(i) Per the terms of Quotation # _____, (ii) Per the terms of GPO # _____; (iii) Per the terms of MPA# _____; or (iv) Per the terms of SAA # _____.

Include applicable quote/agreement number with the reference on the purchase order. In addition, Source of Funds (choice of Cash/Third Party Load or GE HFS Lease Loan or Third Party Lease through _____), must be indicated, which may be done on the Quote Signature Page (for signed quotes), or the Purchase Order (where quotes are not signed) or via a separate written source of funds statement (if provided by GE Healthcare).”

Catalog Item Details

Line	Qty.	Catalog	
	1.00	W0301MR	TIP MR 1.5T Training Program

This training program is designed for customers purchasing a GEHC 1.5T MR system. GEHC will work with the designated Customer contact to agree upon a reasonable training schedule for a pre-defined group of core technologists that will leverage blended content delivery and may include a combination of onsite days and virtual offerings, to include TiP Virtual Assist, the GEHC Answerline and available on-demand courses (“Virtual Inclusions”). This blended curriculum with multiple delivery platforms promotes learner retention and allows for an efficient and effective skill development.

This program may contain:

- Onsite training (generally 12 days)
- Virtual Inclusions may include:
 - Remote instructor-led training: Instructor leads a remote training session one-on-one or in a group, typically for 1 hour
 - Answerline Support-Access to GEHC experts for clinical, non-emergency applications assistance via phone or by using the iLinq button on the imaging console
 - Tip Virtual Assist-Direct interactive access to a GEHC expert for enhanced support.
 - On Demand courses-On healthcare learning system. Self-paced courses and webinars (CE and non-CE).

Training will be delivered at a mutually agreed upon time between the customer and GE Healthcare (excluding GE Healthcare holidays and weekends), are subject to availability and generally will not exceed 15 days. This training program has a term of six (6) months commencing on Acceptance, where all onsite training must be scheduled and completed within six (6) months of Acceptance and all Virtual Inclusions also expire at the end of such six (6) month period. Additional onsite days may be available for purchase separately. All GEHC “Training” terms and conditions apply. Given the unique nature of this program, if this program is purchased as part of a purchase under a Governing Agreement, including any Master Purchase Agreement, Group Purchasing Organization Agreement, or Strategic Alliance Agreement, this program shall take precedence over any conflicting training deliverables set forth therein.

Line	Qty.	Catalog	
	1.00	W0305MR	JUMPSTART PROTOCOL DEVELOPMENT - MR

This development session is designed for two customer representatives who will integrate with GE Healthcare specialists to promote early confidence in the use of the MR system. The jumpstart program will drive optimization of the top 10 protocols used at the customer site resulting in faster implementation of effective customer workflows. This two-day scanning session should be scheduled prior to the customer’s go-live start date.

Courses must be scheduled through appropriate GEHC systems. The course includes tuition, airfare, hotel and meals through the extent of the two-day scanning session for up to two customer representatives. The session is held at GEHC headquarters in Waukesha, WI.

Line	Qty.	Catalog	
	2.00	W0311ALL	TIP SYSTEM TRAINING MILWAUKEE

This training program is designed for an employee of customer to attend a system training course held near Milwaukee, Wisconsin, at the GE Healthcare Institute. Training course must be scheduled through GE Healthcare’s training registration system. Price includes tuition only. Separate packages may be purchased for travel options. Training must be completed within 12 months from purchase.

Line	Qty.	Catalog	
	2.00	W0320ALL	TRAVEL PACKAGE AIRFARE

The travel airfare package is intended to allow customer the convenience of prepaying its roundtrip airfare expenses when attending a Clinical Education course at the GE Healthcare Institute. If customer stays at a GE Healthcare-designated hotel, transportation to and

from the airport will be provided by the hotel. If customer stays at a non-GE Healthcare designated hotel, customer is responsible for its transportation. Customer must make its travel arrangements through a designated GE Healthcare representative. Directions will be provided to customer upon confirmation of training course. The package will expire 12 months from purchase.

Line	Qty.	Catalog	
	2.00	W0321ALL	TRAVEL PACKAGE MEALS & LODGING

This meals and lodging package is intended to allow customer the convenience of prepaying some of its meals and lodging expenses when attending a Clinical Education course at the GE Healthcare Institute. Price is based on a per day basis. Lodging will be at a GE Healthcare-designated hotel. Breakfast is provided by the hotel and lunch is provided at the GE Healthcare Institute. Dinner and weekend meals are customer's responsibility. Transportation to and from the airport and to and from the GE Healthcare Institute is provided by the GE Healthcare-designated hotel. Customer must make its travel arrangements through a designated GE Healthcare representative. Directions will be provided to customer upon confirmation of training course. GE Healthcare will not provide reimbursement for meals not included or for students that fail to comply with directions. The package will expire 12 months from purchase.

Total Quote Net Selling Price: \$61,917.26

GPO Agreement Reference Information

Customer:	Rutland Regional Medical Center
Contract Number:	Novation Vizient Supply LLC
Billing Terms:	80% on Delivery / 20% on Acceptance
Payment Terms:	45 Net
Shipping Terms	FOB DESTINATION

Offer subject to the Terms and Conditions of the applicable Group Purchasing Agreements currently in effect between GE Healthcare and Novation Vizient Supply LLC

If applicable, for more information on this devices' operating system, please visit GE Healthcare's product security portal at: <https://securityupdate.gehealthcare.com/en/products>

This product offering is made per the terms and conditions of Vizient /GE Healthcare GPO Agreements as follows:

Imaging:

XR0391-MR, XR0702-Card./Vasc., XR0673-CT, XR0342-Mammo, XR0351-PET-CT, XR0362-Nuc Med, XR0380-R&F/RAD & XR0592-ICAR-EP/HEMO

Ultrasound:

XR0431-Ultrasound

Vizient: Please login to the Vizient Marketplace Website. If you require assistance or are experiencing issues, please contact Vizient for support:
Email: Connect@VizientInc.com and Phone: 866-600-0618.

RUTLAND REGIONAL MEDICAL CENTER

Physical Location Account #: 205242

Optional: Person(s) to be notified when this document is processed:

Support and prices quoted below are valid provided the customer signs and returns this quote to GE Healthcare by 7/7/2021

Name(s): _____
 Email(s): _____

Equipment Identifiers	Trans. Type	Equipment	Effective Date	Offering	Options	Features	Incremental Annual Amount	Comments
System ID: TBD0001 Phy Loc Acct: 205242 Contract: 0344742 MSA - 2013- 0	ADD POS	GE MR 1.5T SIGNA ARTIST (M#5SA)	End of Warranty through 12/31/2028	AssurePoint Rapid	INCLUDED: • APM Predict: OnWatch • Continuity: Advance - Unlimited base system SW & HW upgrades if required to support such base system SW upgrades (annl amt includes \$7,500/yr fee); OS end of support (annl amt includes \$500/yr fee) • GE SUPPLIED COILS • ILINQ RESPONSE TIME: 5 MIN. • SPECTROSCOPY • TDI COIL SUITE INCL. PATIENT TABLE EXCLUDED: • CHILLER COVERAGE • MAGNET MAINTENANCE & CRYOGEN • PERIPHERAL DEVICES • Printers • Sentinelle Breast Imaging Table • UNINTERRUPTED POWER SUPPLY • WORKSTATION	• FE Coverage Weekdays: Mon-Fri 8AM-Midnight • FE Coverage Weekend: NO COVERAGE HRS • FE Onsite Response Time: 2-Hours • IAC Physicist Support: Excluded • iCenter • InSite/Tech Phone Support • MR Touch: Excluded • PM Coverage HOURS/DAYS: Mon-Fri 8AM- Midnight** • Repair Parts: Included, Next Day 10:30 AM LST- MR • Software and Quality Updates • Special Parts Handling Fee: No charge for Hard Down • Third Party Software: Excluded • TIP Answer Line • TIP-Ed Online(TV) Subscription • TVA on Demand • Uptime Commitment: 98% • ViosWorks HW: Excluded	\$120,500	
System ID: TBD0002 Phy Loc Acct: 205242 Contract: 0344742 MSA - 2013- 0	ADD POS	GE MR MR MAGNET MAINTENANCE AND CRYOGEN (MSC28Z)	End of Warranty through 12/31/2028	Magnet Maintenance and Cryogen	INCLUDED: • APM Predict: OnWatch • MAGNET: 0.5T, 1.0T, 1.5T (NON-TWIN)	• FE Coverage Weekdays: MON-FRI, 8AM-9PM • InSite/Tech Phone Support • Magnet Repair Parts: Included, Next Day 10:30 AM LST-MR • Parts Shipping: Included, Next Day 10:30 AM LST-GENERAL • Third Party Software: Excluded	\$33,100	
System ID: TBD0003 Phy Loc Acct: 205242 Contract: 0344742 MSA - 2013- 0	ADD POS	DIMPLEX MV PR DIMPLEX WO2-2- 5000 CHILLER 20T (SDI020)	End of Warranty through 12/31/2028	AssurePoint Standard	INCLUDED: • CHILLER AGE: CHILLER AGE <10 YEARS EXCLUDED: • City Water Bypass or Other H/W • R22 Refrigerant	• FE Coverage Weekdays: MON-FRI, 8AM-5PM • FE Onsite Response Time: 24 Hours • PM Coverage HOURS/DAYS: MON-FRI, 8AM- 5PM • Repair Parts: Included, Next Day 10:30 AM LST- GENERAL	\$5,900	
System ID: TBD0004 Phy Loc Acct: 205242 Contract: 0344742 MSA - 2013- 0	ADD POS	PRODYSC MV PR ProDySC Dynamic Sag Corrector 200 AmP (SPR200)	End of Warranty through 12/31/2028	AssurePoint Standard		• FE Coverage Weekdays: MON-FRI, 8AM-5PM • FE Onsite Response Time: 6-Hours • PM Coverage HOURS/DAYS: MON-FRI, 8AM- 5PM • Repair Parts: Included, Next Day 10:30 AM LST- GENERAL	\$7,520	

Equipment Identifiers	Trans. Type	Equipment	Effective Date	Offering	Options	Features	Incremental Annual Amount	Comments
System ID: TBD0005 Phy Loc Acct: 205242 Contract: 0344742 MSA - 2013- 0	ADD POS	MEDRAD MV PR MEDRAD MR XPERION (SME080)	End of Warranty through 12/31/2028	AssurePoint Standard		<ul style="list-style-type: none"> • FE Coverage Weekdays: MON-FRI, 8AM-5PM • FE Coverage Weekend: NO COVERAGE HRS • FE Onsite Response Time: 24 Hours • PM Coverage HOURS/DAYS: MON-FRI, 8AM-5PM • Repair Parts: Included, Next Day 10:30 AMLST-GENERAL 	\$6,500	

NET ADJUSTMENT TO CONTRACT:	\$173,520
------------------------------------	------------------

The Agreement is hereby amended as follows. The Product above is added, deleted, or modified as indicated. Service for additions or modifications continues until Agreement expiration. In the event of conflict between this Addendum and the Agreement, this Addendum prevails. The Addendum start date is: (a) the above Effective Date if Customer signs and returns this Addendum within 30 calendar days of that date; or (b) the date of signature if Customer does not sign and return this Addendum within 30 calendar days of the above date.

Customer: Approved By: _____ Title: _____ Signature: _____ Date: _____	GE Precision Healthcare LLC, a GE Healthcare business: Approved By: _____ Title: _____ Signature: _____ Date: _____
---	--

1. Continuity Advance.

1.1. **Base-System Upgrades.** During the Continuity Term, GE Healthcare will provide (i) base-system software upgrades for the Equipment as identified on the Product Schedule, and (ii) hardware upgrades if such hardware upgrade is required to support the base-system software upgrades, if and when such base-system software and hardware upgrades are commercially available. If any base-system software upgrades require hardware beyond the hardware upgrade that may be provided under Continuity Advance, GE Healthcare has no obligation to provide such base-system software upgrades until Customer has purchased the required hardware (e.g., equipment enclosure, custom cables). All product-related terms for upgrades (e.g., warranty, installation, late payment) are identified in the GE Healthcare Terms and Conditions and the Equipment Warranty Statement to which the Continuity Advance upgrade applies. CONTINUITY ADVANCE DOES NOT PROVIDE ADDITIONAL EXPRESS OR IMPLIED WARRANTIES.

1.2. **OS End of Life/Support.** If the Equipment's operating system is no longer supported by the operating system's OEM during the Continuity Term, GE Healthcare will provide: (i) commercially available software updates and/or software upgrades that: (a) are required to ensure a supported operating system in the Equipment, and (b) have been validated by GE Healthcare to be compatible with the Equipment; and (ii) enabling hardware, if any, that is required for the Equipment to run the operating system, (collectively, "**OS Updates, Upgrades and Enabling Hardware**"). Installation of OS Updates, Upgrades and Enabling Hardware will be performed by GE Healthcare during the next scheduled Equipment planned maintenance service ("**PM**") if GE Healthcare is performing PM on the Equipment under this Agreement, or at a mutually agreed upon time.

2. **Price and Payment.** Pricing for Continuity Advance will be identified on the Product Schedule for the Equipment to which Continuity Advance applies as either a separate line item price or contained in the Options column. No part of the Continuity Advance price is refundable or subject to reduction, and payments are not contingent on GE Healthcare's delivery, or Customer's acceptance, of any particular OS Updates, Upgrades and Enabling Hardware, base-system software and/or hardware upgrade, or any other products or service under Continuity Advance.

3. **Cost Reporting.** Customer is aware of its cost reporting and accounting obligations required by any state or federal reimbursement health care program relating to Continuity Advance and Services provided under this Agreement. Customer will review the Product Schedule to obtain the Continuity Advance price and will request from GE Healthcare any additional information needed to fulfill Customer's cost reporting obligations.

4. **Term and Termination.** Continuity Advance will have the start and end dates identified in the Effective Date column of the Product Schedule for the Equipment to which Continuity Advance applies ("**Continuity Term**"). In no event will the Continuity Term be less than 36 months. The Continuity Term is non-cancelable. If this Agreement terminates or the Equipment to which Continuity Advance applies is removed from this Agreement prior to the end of the Continuity Term, Customer is responsible for any remaining Continuity Advance amounts due to GE Healthcare through the Continuity Term, and Customer will pay all remaining amounts within 30 days after termination or removal. Customer remains responsible for the Continuity Advance price regardless of termination, expiration or any other event relating to this Agreement.

5. **Exclusions.** Except as identified above, Continuity Advance excludes: (i) Product replacements; (ii) Product upgrades; (iii) accessories, supplies and consumable items; (iv) any Software; (v) advanced operating system applications or features; (vi) physicist testing and calibration; and (vii) training. Products are excluded from coverage under this Agreement and Customer is not entitled to any remedy if GE Healthcare's failure to perform hereunder is due to: (a) Customer cancellation, rescheduling, or inability of GE Healthcare to access the Product; (b) Customer's default; (c) improper care of the Product; or (d) any cause beyond GE Healthcare's control. GE Healthcare is not responsible for providing system database maintenance for Customer, including but not limited to, activities related to backup, new users, user privileges, physician list updates, and archive/data entry.

6. Miscellaneous.

6.1. Customer is responsible for: (i) site preparations, construction and rigging that may be required for Continuity Advance; (ii) ensuring that all data is appropriately backed up prior to installation of OS Updates, Upgrades and Enabling Hardware; and (iii) purchasing any catch-up updates and/or upgrades needed for Continuity Advance.

6.2. OS UPDATES, UPGRADES AND ENABLING HARDWARE PROVIDED UNDER THIS AGREEMENT ARE "AS IS" AND "AS AVAILABLE" WITH NO WARRANTY OF ANY KIND, EXPRESS OR IMPLIED, INCLUDING, BUT NOT LIMITED TO, WARRANTIES OF NON-INFRINGEMENT, MERCHANTABILITY OR FITNESS FOR A PARTICULAR PURPOSE. GE HEALTHCARE MAKES NO REPRESENTATIONS, WARRANTIES OR CONDITIONS THAT SUCH OS UPDATES, UPGRADES AND ENABLING HARDWARE, OR EQUIPMENT WILL BE UNINTERRUPTED, TIMELY, SECURE, ERROR-FREE OR MEET CUSTOMER REQUIREMENTS OR ANY NATIONAL GUIDELINE OR INDUSTRY STANDARD.

6.3. Products, equipment, components, software and/or hardware replaced or removed by GE Healthcare under this Agreement will become GE Healthcare's property.

6.4. Equipment that is declared end of life/support by GE Healthcare is not eligible for Continuity Advance.

6.5. If Customer assigns this Agreement, all remaining Continuity Advance payments become immediately due and payable by Customer on assignment.



Formal Quotation

Document number: 2301185395
Date of issue: 07/02/2021

Sold to (94037337):
RUTLAND REGIONAL MEDICAL CENTER
160 Allen St
RUTLAND VT 05701-4595
UNITED STATES

Last updated: 07/02/2021 14:06:30

Expiration date: 09/02/2021

Our federal tax ID #: 133429115

Our contact details

Account Manager: Open Hartford

Incoterms: FOB DESTINATION

Payment terms: Within 30 Days Due Net

Item	Product and Description	Quantity	UoM	Price/Unit	Amount
Service quote to be used in conjunction with capital quote # 2301185394					
10	890416 Patient Care Service Agreement	1	PCE	List Price	13,488.00
	A11 3 Years of Service	1	PCE	0.00/1 PCE	0.00
	B04 Comprehensive Onsite	1	PCE	0.00/1 PCE	0.00
				Net amount	13,488.00/1 PCE
20	890416 Patient Care Service Agreement	1	PCE	List Price	2,253.00
	A11 3 Years of Service	1	PCE	0.00/1 PCE	0.00
	B04 Comprehensive Onsite	1	PCE	0.00/1 PCE	0.00
				Net amount	2,253.00/1 PCE
Total net amount					15,741.00

Philips Healthcare is pleased to inform you that financing of its products and services is available to qualified applicants. To obtain more information contact Philips Medical Capital @ 866-513-4PMC.

MD Buyline -- Please be aware that MD Buyline utilizes Philips current list prices as the basis of calculation for discount comparisons. If you are a customer utilizing a GPO contract with fixed pricing, it is likely that the list price on this quotation is based on an older published price list, and may be considerably less than the current list pricing that MD Buyline uses in its analysis. As such, the MD Buyline discount recommendation may be higher than the Philips offering for your particular purchase. If you have a question, please ask your Sales Representative for clarification. Should you have concerns or want additional information relative to how discount comparisons are calculated at MD Buyline, please call your analyst at MD Buyline.

Via ACH/EFT:
Payee: Philips Healthcare
Bank: Bank of America
Account#: 3750202223
ABA#: 1110-0001-2

Via Check:
Philips Healthcare
P.O. Box 100355
Atlanta, GA 30384-0355





Formal Quotation

Document number: 2301185395

Date of issue: 07/02/2021

All work is scheduled within normal working hours; Monday through Friday, 8 a.m. to 5 p.m. excluding Philips holidays. All pricing is based on travel zones 1-3. For travel zones beyond 1-3, consult your Philips sales rep for alternate pricing. It is the customers responsibility to provide Philips with the access necessary to complete the quoted work in a continuous start to finish manner. Excessive delays and multiple visits will result in additional charges. All prices are based upon 'adequate access' to work areas that are free from obstruction. If it is determined, during the implementation that asbestos removal is required; Philips will suspend performance until the Customer remediates the asbestos. Philips will work with the customers staff to reduce the downtime during the system transition.

Products are for USA end-use only. Taxes, if applicable, are not included unless noted but will be added to the invoice. The Purchase Order must reference the Quote Number and your Purchase Agreement. Please indicate your requested delivery date and your preference, if any, to accept and pay for partial shipments. If this quote includes Value-Added Services, they may be invoiced separately. Additional sold training must be completed within twelve months of delivery/installation. System cabling, if included, is specified at the standard grade unless noted otherwise.

This quote specifically excludes Licensing & Permit Fees, Prevailing Wage Compensation and Union Labor.

IMPORTANT NOTICE: Health care providers are reminded that if the transactions herein include or involve a loan or a discount (including a rebate or other price reduction), they must fully and accurately report such loan or discount on cost reports or other applicable reports or claims for payment submitted under any federal or state health care program, including but not limited to Medicare and Medicaid, such as maybe required by state or federal law, including but not limited to 42 CFR1001.952(h).

This quotation is issued pursuant to, and any PO for the items herein will be accepted subject to the Terms of any current Contract with the customer. If there is no contract in place, this quotation is issued pursuant to, and any PO for the items herein will be accepted subjected to Philips Terms and Conditions of sale posted at <http://www.usa.philips.com/healthcare/about/terms-conditions> and the terms herein.

This quotation contains confidential and proprietary information of Philips Healthcare and is intended for use only by the customer whose name appears on this quotation. It may not be disclosed to third parties without prior written consent of Philips Healthcare.

Save time and effort on your next order.

Try online ordering!

The Philips Healthcare Store has many of the consumables and supplies you order as a healthcare professional. Check out the store today; it's easy to register!

<http://www.patientcare.shop.philips.com/>

Please send purchase orders via email, fax or mail to:

Email: Healthcare.Orders@philips.com

Fax: 1-800-947-3299

Philips Healthcare
A division of Philips North America LLC
414 Union St, 2nd Floor
Nashville, TN 37219

Via ACH/EFT:
Payee: Philips Healthcare
Bank: Bank of America
Account#: 3750202223
ABA#: 1110-0001-2

Via Check:
Philips Healthcare
P.O. Box 100355
Atlanta, GA 30384-0355





December 22nd 2016

Jonathan Reynolds
VP - Clinical Services
Rutland Regional Medical Center

Dear Customer:

We understand how important it is to your long-range planning to be able to anticipate any changes to the status of your maturing diagnostic imaging equipment. As your service provider, GE Healthcare would like to provide you with advance notice of an upcoming change to the serviceability of your scanner.

GE Healthcare will no longer offer full service support for the product listed below. However, as part of the GE MR Continuum™ we continue to have long term ability to service your magnet if it is an "LCC" also referred to as "CXX4" design.

Product

SIGNA LX (9x operating system) – End of full service support: June 30th 2019

SINGA EXCITE (11x operating system) – End of full service support: December 31st 2019

System ID

802747MR

Many factors are considered when determining that a product has reached end-of-life status. As equipment ages and technology advances, outside suppliers cease to produce many of the parts and components contained in older systems. We project that in the near future, certain components will be virtually unobtainable. This impairs our ability to provide full service support.

If you have a system currently under service contract with GE, we will be contacting you shortly to discuss available service options.

Your local GE Healthcare team will work with you to understand what products or services are available to help support your imaging needs and upgrade to more advanced technology.

Please visit the SIGNA legacy center www3.gehealthcare.com/legacySIGNA where you can also find additional information provided by GE Healthcare to help understand and evaluate the options available. If you have immediate questions or concerns, please contact your local GE sales or service representative. Thank you for your continued business with GE.

Sincerely,

Bryan Mock
GM, MR Product Management

Jason Early
Director, MR Modality Service

Shari Patch

From: Gallagher, Patrick (GE Healthcare) <Patrick.Gallagher@ge.com>
Sent: Tuesday, March 9, 2021 11:25 AM
To: Shari Patch
Cc: Ashe, Edwina (GE Healthcare)
Subject: EOSL Letter for 802747MR
Attachments: 802747MR EOSL letter 12.22.2016.pdf

[External Email] This email originated from outside of the organization. **Think before you click:** Don't click on links, open attachments or respond to requests for sensitive information if the email looks suspicious or you don't recognize the sender.

Hi Shari,

I was able to catch up with AJ yesterday and he provided me with the EOSL document for your system. As we discussed we did experience issues obtaining a board this past year due to the age of this system which caused the system to be down longer than we had anticipated. As this system continues to age these situations could become more frequent, but our team will do our best to continue to service this unit. We appreciate your partnership and want to thank you for all you do keeping the GE Team updated with what is going on at the facility.

Thanks Patrick

Patrick F. Gallagher

Director of Service, DI and Biomed Northern New England
GE Healthcare

Cell 617-970-3720

www.gehealthcare.com



GE Healthcare

GE Healthcare
Product Management
9900 Innovation Drive
Wauwatosa, WI 53226 USA

Rutland Regional Medical Center
160 Allen St
Rutland, VT 05701-4595

March 21, 2021

IMPORTANT END OF SERVICE SUPPORT NOTIFICATION FOR CERTAIN MR INVIVO SURFACE COILS

We know it is important to your planning to have advanced notice of changes in the status of your maturing medical equipment. That's why we take a proactive approach to notify you when our products will reach an end of service support (EOSS) status.

Our records indicate that your facility has one or more MR Invivo surface coil(s) that will reach its EOSS status as of March 31, 2022. Please refer to the table at the end of this notification for details. This EOSS notice only impacts the listed coil(s) and does not impact the rest of the MR system. After the EOSS date, GE Healthcare will no longer offer service contract coverage for the coil(s) and will remove the coil(s) from your GE Healthcare service agreement coverage (if applicable). Until the EOSS date, GE Healthcare will continue to deliver to our service contract commitments.

We consider many factors when determining that a product has reached EOSS. As equipment ages and technology advances, suppliers are unable to procure parts and components necessary to maintain older product designs. In the case of these specific coils, Invivo has stopped production. We understand that removing the coil(s) from service coverage is certainly not ideal. To help minimize the impact of this EOSS notification, GE Healthcare is offering discounted pricing to trade-in your current coil and upgrade to a supported coil.

Thank you for your trust and confidence in our products and solutions. We look forward to a continued relationship with you and to meeting your future equipment and service needs. Please contact your GE Healthcare team with any questions and to discuss options.

Sincerely,

Tyler Jones
MR Service General Manager

Product Model Name	Equipment Description	System ID(s)
M3087JB	1.5T 8-CHANNEL NV ARRAY IMAGING COIL	802747MR

Shari Patch

From: Bobby Sanborn <rsanborn@iradimed.com>
Sent: Tuesday, December 4, 2018 2:41 PM
To: Shari Patch
Subject: Your MRI Pump is End of Life

[External Email] This email originated from outside of the organization. **Think before you click:** Don't click on links, open attachments or respond to requests for sensitive information if the email looks suspicious or you don't recognize the sender.

[Click here](#) to view this message in a browser window.

Sherry,

We hope you are doing well as the year comes to a close.

We regret to inform you that your current Iradimed MRidium 3850 MRI infusion pump has reached its end-of-life cycle. This product has been discontinued for over 4 years and will be completely obsolete come May of 2019.

With that said, we would like to offer a trade in value as you plan to upgrade to our new [MRidium 3860+](#) model. You likely already have a replacement quote in hand, but we would like to offer possible additional incentives as the year comes to a close. As you know, our MRI infusion pump provides the safest method to deliver IV medications to those patients requiring critical infusions during their MRI scans. We want to ensure you do not run into a scenario where you may be required to delay a patient's scan or cancel it all together due to an end of life product not being upgraded within its life cycle.

Please let us know how we can help with your upgrade.

Thank you!

Bobby Sanborn

Territory Sales Manager

rsanborn@iradimed.com

Copyright © 2017 IRadimed
Our address is 1025 Willa Springs Drive, Winter Springs, FL 32708, USA.

If you do not wish to receive future email, [click here](#).
(You can also send your request to Customer Care at the street address above.)





August 1, 2018

Dear Valued Bayer Customer:

This letter is to inform you that Bayer will end of contract the MEDRAD® Spectris® MR Injection System (not the MEDRAD Spectris® Solaris MR Injection System) as of January 1, 2019. Medrad Inc. discontinued the sale of its first generation MR injection system, Spectris® MR Injection System in October of 2003.

End of contract means we will no longer offer new service contracts for the MEDRAD® Spectris® MR Injection System.

All existing contracts will be honored through the end of their term, and customers can expect the same level of service and reliability from our field team. Bayer Field Service Engineers will continue to provide our customers with predictive maintenance (PM) and time and material service, as long as spare parts are available.

This announcement is a part of our ongoing commitment to innovate and invest in products to enhance and improve the MR modality. We know you have relied on the MEDRAD® Spectris® MR Injection System for your contrast enhanced procedure needs, now we would like to introduce you to the our next generation contrast injector that can offer SMART technology for your MR suite to drive work flow efficiencies, the MEDRAD® MRXperion™ MR Injection System.

MEDRAD® MRXperion™ MR Injection System product highlights:

- Bayer's latest injector and disposable syringe technology is a SMART Injection System that helps precisely administer contrast media during MRI procedures.
- Provides reproducible quality, operational consistency, and seamless network communication with Contrast Dose Management.
- Backed by On-site Field Service and VirtualCare® Remote Support* for advanced injection system diagnostics and real-time support.

Please contact your local Bayer Portfolio representative or visit www.radiologysolutions.bayer.com to assist with any questions.

Sincerely,

A handwritten signature in blue ink, appearing to read "Rich Dewit".

Rich Dewit
Head, US Sales, Marketing

**Included during warranty period when activated. Additional coverage available for purchase.*

[Privacy Policy](#) | [Conditions of Use](#) | [Unsubscribe](#)

© 2018 Bayer
Bayer HealthCare LLC, 100 Bayer Boulevard, PO Box 915, Whippany, NJ 07981

PP-MRD-US-0005- August 2018

Bayer, the Bayer Cross and MEDRAD Spectris MR Injection System injection system are trademarks of the Bayer group of companies.

TOMORROW TODAY



SIGNA™ Artist

AIR™ IQ Edition data sheet



Magnet	3
Gradient	4
RF.....	5
Volume Reconstruction Engine & Host Computer	6
Computing Platform	7
Scan Parameters	8
SIGNA™Works.....	9
NeuroWorks.....	10
BodyWorks.....	11
CVWorks.....	12
OrthoWorks.....	13
OncoWorks.....	14
PaedWorks.....	15
SIGNA™Works Features.....	16
Image Acquisition.....	22
RF Coils Suite.....	29
SIGNA™ Flow	40
Air X™	41
Air™ Recon DL.....	42
oZTEo MR Bone Imaging	43
Patient Setup.....	44
In-line Processing & In-line Viewing	46
Scanning	47
Visualization.....	48
READYView.....	49
Siting.....	52
Miscellaneous	53

Magnet

The foundation for quality and flexibility

When it comes to image quality and applications flexibility, no other component of an MRI system has greater impact than the magnet architecture.

The SIGNA™ Artist system features a platform wide bore magnet that delivers a large field of view. The magnet geometry has been optimized to reduce patient anxiety by providing more space in the bore and more exams with the patient's head out of the magnet. The 55 cm* field of view provides uniform image quality and may reduce exam times since fewer acquisitions may be necessary to cover large anatomy.

Magnet Specifications

Magnet Length	179 cm
Operating field strength	1.5T (63.86 MHz)
Magnet shielding	Active
Magnet Shimming	Active and Passive
EMI Shielding Factor	99%
Magnet weight with cryogenes	7,275 lbs (3,300 kg)
Magnet cooling	Cryogenic (liquid helium)

Diameter Volume (x, y, z)	Typical ppm	Guaranteed ppm
10 cm DSV	0.007	0.02
20 cm DSV	0.035	0.06
30 cm DSV	0.10	0.15
40 cm DSV	0.33	0.43
45 cm DSV	0.88	1.0
48 cm DSV	1.75	2.0
50 cm DSV	2.8	3.3

Volume Root-Mean-Square (V-RMS) values are computed from 24 measurements on each of 32 planes with linear terms set to zero

Patient bore

Patient Bore (L x W x H)	105 cm x 70 cm x 70 cm
Patient Aperture	76 cm
Patient comfort module	Head or feet first entry
	Dual-flared patient bore
	2 way in-bore intercom system
	Adjustable in-bore lighting system
	Adjustable in-bore patient ventilation system

*Under normal operating

**FOV 50cm in Z direction*FOV 50cm in Z directionconditions

Gradient

Premium clinical performance is enhanced with the SIGNA™ Artist gradient system. Gradient speed, accuracy and reproducibility are critical for all acquisitions, but the performance is especially important in challenging acquisitions, such as fMRI, diffusion, and PROPELLER.

ART (Acoustic Reduction Technology)

State-of-the-art clinical imaging demands the routine use of ultra-fast imaging techniques. At 1.5T, the strong gradients interact with the magnetic field to create mechanical forces resulting in acoustic noise. GE has implemented Quiet Technology on many components of the system to reduce acoustic noise and improve the patient environment.

Gradient Coil Isolation and Acoustic Damping

The full performance of the Extreme Gradient Driver is used while helping to maintain a safe environment for the patient. Clear separation between the gradient coil, RF body coil, and patient support structures ensures minimal component interactions. In addition, mass-damped acoustic barriers are used under the system enclosures to further reduce acoustic noise for the patient.

RF Coil Isolation

During gradient pulses, the RF body coil acts as a secondary source of noise. To further reduce the noise heard by the patient, the RF body coil mounting has been optimally designed with features to reduce acoustic noise.

Vibro-Acoustic Isolation

To isolate the magnet from the building and reduce the transmission of acoustic noise in the structure, GE has designed a vibro-acoustic dampening pad that sits under the feet of the magnet. The dampening characteristics of the pad are optimized based on the magnet geometry and weight.

Gradient Waveform Optimization

User selectable mode to further reduce acoustic noise.

Gradient Performance

Peak amplitude	44 mT/m
Slew-rate	200 T/m/s
Maximum FOV*	55 cm X 55 cm X 50 cm
Duty Cycle	100%

Gradient amplifier (water-cooled)

Gradient amplifier	830 Amps/1650 VoltsPeak
Current and Voltage	Frequency dependent feed-forward model
Control	Digital PI feedback control loop

Peak gradient specifications determined through maximum measured gradient amplifier output and gradient coil efficiency.

Typical gradient fit expressed in terms of the absolute integrated errors in micro-Amperes-second (μ As). Gradient integral precision is the maximum integrated current error over a full-scale, echo-planar gradient waveform. Shot-to-shot repeatability is the largest difference between integrated errors across waveforms. Symmetry is the largest difference in integrated current error when comparing positive and negative gradient waveforms.

RF Architecture Total Digital Imaging

The RF acquisition technology of the SIGNA™ Artist 1.5T enables greater clinical performance and higher image quality especially for data-intensive applications and provides an improvement in SNR versus previous generation based on GE's Total Digital Imaging (TDI) RF architecture.

Direct Digital Interface (DDI) employs an independent analog-to-digital converter to digitize inputs from each of up to 128 RF channels, eliminating unnecessary noise enhancement. In other words, every element translates to a digitized signal. The result? Not only does DDI technology improve SNR of our images but it also works with legacy GE coils for unmatched flexibility.

RF Architecture

Receiver sampling per channel	80 Mhz
Quadrature demodulation	Digital
Receiver dynamic range at 1 Hz BW	> 165 dB
Receiver resolution	Up to 32 bits

TDI Receive RF Architecture for 128 channels system

Maximum number of channels per Field of View without table movement each generating an independent partial image	128
--	-----

TDI Receive RF Architecture for 96 channels system

Maximum number of channels per Field of View without table movement each generating an independent partial image	96
--	----

TDI Receive RF Architecture for 64 channels system

Maximum number of channels per Field of View without table movement each generating an independent partial image	64
--	----

Standard RF transmit architecture

RF Amplifier	Water cooled, small footprint
Maximum output power	16 kW Body 2 kW Head
Maximum RF field with integrated body coil	>20 uT
Transmit gain	>100 dB (40 dB coarse/ >84 dB instantaneous)
RF exciter frequency range	63.86 ± 0.650 MHz
Frequency resolution	< 0.6 Hz/step
Frequency stability	14 parts per billion (0 to 50 C)
Phase resolution	0.005 degree/step
Amplitude control	16 bit with 12.5 ns resolution
Amplitude stability	<0.1 dB over one min. at rated power
Digital RF pulse control	2 amplitude modulators, 2 frequency/phase modulators

Volume Reconstruction Engine & Host Computer

Reconstruction performance today is challenged by explosive growth in data, and increased computational complexity. The amount of data to be stored and processed continues to increase with the advances in MR system technology. The SIGNA™ Artist meets that challenge head-on with innovations in reconstruction to take full advantage of computing power and by leveraging both hardware and software technology.

Reconstruction System Gen7			
	PERFORMANCE	ADVANCED*	PERFORMANCE-DL
Operating system	Scientific Linux	Scientific Linux	Scientific Linux
Processor	Dual Intel Xeon Gold 5118	Dual Intel Xeon Gold 6130	Dual Intel Xeon Silver 4214 processor
Clock rate	2.3 GHz	2.1 GHz	2.2 GHz
Memory	>= 128GB	>= 192GB	>=128GB
Network	1 GbE	10 GbE	1 GbE
Hard disk storage	960 GB SSD	1440 GB SSD	>=960 GB
2D FFT/second (256 x 256 full FOV)	63,000 2D FFTs/second	81,000 2D FFTs/second	63000 2D FFTs/second
GPU	NA	NA	Nvidia T4

Host Computer	
Operating system	Scientific Linux (RT)
Processor	Intel Xeon W-2123 CPU
Clock rate	3.6 GHz
Memory	64 GB
Network	Gigabit (10/100/1000) Ethernet
Hard disk storage	1024 GB SSD
Graphics subsystem	NVIDIA Quadro with minimum of 1 TFLOPS performance
Media drives	CD/DVD drive
Cabinets	Single, tower configuration

Orchestra Reconstruction Platform

Orchestra is a high performance computing software library toolbox that enables new possibilities for integration of advanced reconstruction elements. Delivering enhanced productivity gains by increased image reconstruction speed and minimizing workflow disruptions. A powerful platform not only built to support the most demanding application such as HyperSense, but also to provide our collaborators with easy access to the product reconstruction algorithms.

AIR™ Recon™

Reconstruction is at the heart of every scan, and reducing noise during reconstruction is critical to achieving clear images.

With AIR™ Recon™, GE's smart reconstruction algorithm available on several key applications like PROPELLER, Cube, FSE and Flex, you can reduce background noise and out-of-FOV artifacts while improving SNR. The result is cleaner, crisper images without having to overcompensate in your scanning protocol.

AIR™ Recon DL**

Deep Learning based reconstruction to reduce noise, blurring and ringing artifacts for MR images. AIR™ Recon DL, a GE-first deep-learning application for MR image reconstruction, is designed to improve signal-to-noise and image sharpness, enabling shorter scan times. It uses trained neural networks to remove noise and ringing from the reconstructed image.

*Optional

**AIR Recon DL is not yet CE marked. Cannot be placed on the market or put into service until it has been made to comply with CE marking. Not available for sale in all regions.

Computing Platform

Operator Console

The SIGNA™ Artist system comes equipped with a scan control keyboard assembly that contains intercom speaker, microphone and volume controls, and an emergency stop switch. Start-scan, pause-scan, stop-scan, and table advance to isocenter hot keys are also included.

Display and DICOM Data

The SIGNA™ Artist 1.5T system generates MR Image, Secondary Capture and Grayscale Softcopy Presentation State (GSPS) DICOM objects. The DICOM networking supports both send and query retrieve as well as send with storage commit to integrate with the site's PACS archive. DICOM filming support includes both Basic Grayscale and Basic Color Print Service Classes. Additionally, the SIGNA™ Artist system supports the CT and PET image objects for display allowing the user to refer to cross-modality studies.

Display

AutoView	Dedicated image review window
	6 user-programmable keys on scan control keyboard plus one key for returning to prior setting
Window/Level (W/L)	6 user-programmable buttons in image viewer Arrow keys on scan control keyboard On-image through middle mouse button Save State stores user-selected image orientation, user annotation and window level
	Zoom/Roam/Flip/Rotate/Scroll Explicit Magnify and Magnifying Glass Image Measurement Tools Grid On/Off Cross Reference/User Annotation Exam/Series Page Hide Graphics/Erase Annotation/Screen Save
Image display	Accelerator Command Bar Compare Mode/Reference Image Minified Reference Scoutview Cine Paging (up to 4 windows and 128 images/window) Add/Subtract/Edit Patient Data

Split Exam	Provides the capability to extract a subset of series from an exam and create a separate exam Performed on the locally-accessible image database
Image display performance	256 Image buffer (256 x 256) at 30 fps Shadowed to permit ease in reading
Image annotation	Two graphic/text planes overlay the entire screen Grid placement with anatomical reference on an image Drawing and annotation may be added to and removed from images

Filming

	Drag and Drop filming One-button Print Series One-button Print Page
Filming	Multi-image formats – from 1 to 24 images displayed simultaneously in various layouts DICOM Basic Grayscale Print Service Class DICOM Basic Color Print Service Class

Wide-screen display monitor

Display monitor	24" Widescreen LCD Flat Panel 1920 x 1200 dot resolution Ability to display DICOM images in 2048x2048 matrix
-----------------	--

Scan Parameters

Sequences	Parameters	Matrix 64	Matrix 128	Matrix 256	Matrix 512
2D Spin Echo	Min. TR (ms)	N/A	3.0 ms	4.0 ms	3.04 ms
	Min. TE (ms)	N/A	1.576 ms	1.928 ms	2.784 ms
2D Fast Spin Echo	Min. TR (ms)	N/A	3.0 ms	4.0 ms	6.0 ms
	Min. TE (ms)	N/A	1.608 ms	1.896 ms	2.784 ms
	Min. slice thickness	0.2 mm			
	Min. ESP (ms)	N/A	1.608 ms	1.896 ms	2.784 ms
	Max. ETL	N/A	480		
	Min. TR (ms)	N/A	45 ms	53 ms	74 ms
3D Fast Spin Echo	Min. TE (ms)	N/A	4.0 ms	5.0 ms	7.0 ms
	Min. slice thickness	0.3 mm			
	Min. ESP (ms)	N/A	1.656 ms	2.272 ms	3.712 ms
	Max. ETL	N/A	400	400	400
	Min. TR (ms)	0.554 ms	0.682 ms	0.906 ms	1.308 ms
2D Fast Gradient Echo	Min. TE (ms)	0.184 ms	0.184 ms	0.188 ms	0.192 ms
	Min. TR (ms)	0.54 ms	0.668 ms	0.89 ms	1.25 ms
3D Fast Gradient Echo	Min. TE (ms)	0.184 ms	0.184 ms	0.18 ms	0.18 ms
	Min. slice thickness	0.1 mm			
Inversion Recovery	Min. TR (ms)	N/A	56.8 ms	57.0 ms	59.0 ms
	Min. TE (ms)	N/A	1.608 ms	1.928 ms	2.784 ms
	Min. TI (ms)	N/A	50.0 ms	50.0 ms	50.0 ms
3D FIESTA	Min. TR (ms)	0.91 ms	1.23 ms	1.89 ms	3.04 ms
	Min. TE (ms)	0.24 ms	0.316 ms	0.432 ms	0.628 ms
	Min. TR (ms)	4.0 ms	5.0 ms	5.0 ms	N/A
	Min. TE (ms)	1.1 ms	1.2 ms	1.6 ms	N/A
	Min. slice thickness	0.6 mm			
Echo Planar Imaging	Min. FOV cm	4 cm			
	ESP at 25 cm	0.452 ms	0.656 ms	1.052 ms	N/A
	ESP at 48 cm	0.324 ms	0.452 ms	0.656 ms	N/A
	ESP at 99 cm	0.220 ms	0.308 ms	0.564 ms	N/A
	Images per second	163	163	163	N/A
	b value	Maximum (s/mm ²): 10.000 Max # for ADC: 40			
	Diffusion Tensor directions	Max: 300			
SLICE THICKNESS and FOV					
Minimum slice thickness in 2D					0.1 mm
Minimum slice thickness in 3D					0.1 mm
Min/Max FOV					10 mm/550 mm*
Min/Max Matrix					32-1024

*FOV 50cm in Z direction

SIGNA™Works

The latest software platform provided by GE, it includes the base pulse sequences, workflow enhancements and visualization tools to enable high productivity with exceptional quality and outcomes. SIGNA™Works, starting with the acquisition, provides the tools needed to enable superb results in the various clinical fields. With 6 optimized Works categories, GE delivers preset protocols for the most demanding Neuro, Muskuloskeletal, CardioVascular, Body, Oncology and Paediatric areas. In addition to enabling the routine imaging, SIGNA™Works provides the user with a streamlined and efficient operating environment with in-line processing through single-click outcomes for even the most demanding processes.

SIGNA™Works provides:

- Software platform with a wider range of assets for image acquisition, display and post processing.
- Strategically packaged to deliver speed, high quality diagnostic images and reliable post processing to each clinical area.
- An intelligent combination of MR pulse sequences and advanced techniques, designed to bring solutions for enhanced care and productivity.
- From SE, FSE, frFSE, Inversion Recovery, SSFSE, SSFSE-IR, GRE, FGRE, SPGR, FSPGR to Volumetric imaging, Motion Correction, Diffusion Weighted, Vascular imaging and beyond.

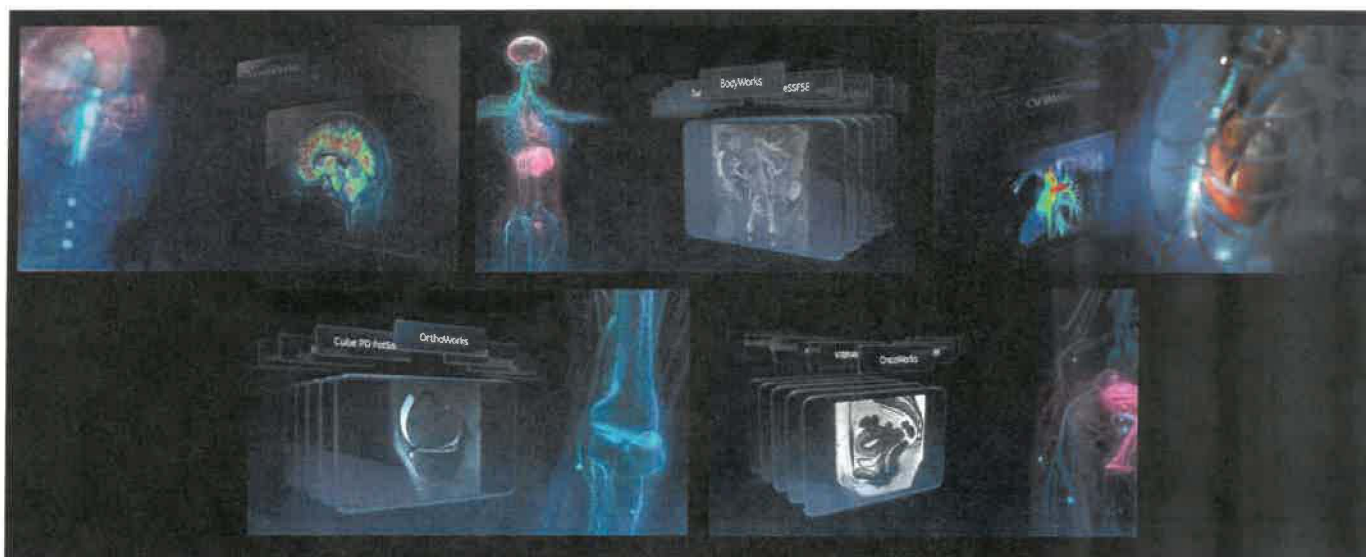

NeuroWorks

NeuroWorks includes the basic imaging acquisitions and processing to the latest in motion correction, functional and volumetrics. Supporting both simple reconstruction to real-time perfusion results with BrainSTAT Arterial Input Function (AIF).

Volumetric Imaging

	PD, T1, T2, T1 FLAIR, T2 FLAIR, STIR, MSDE
3D Cube	Three-dimensional FSE (3D FSE), with flip angle modulation Isotropic high resolution volumetric One sequence, reformat in all planes
3D Cube DIR	DIR, typically but not limited to CSF and white matter suppression
BRAVO T1	< 1 mm isotropic, MP-RAGE optional sequence of choice for functional data overlay
Visualization	3D reformat MPR Volume segmentation Volume rendering Auto-contour

Motion Correction

PROPELLER MB	Multiple contrasts – T1, PD, T2, T1 FLAIR, T2 FLAIR and DWI Motion reduction Magnetic susceptibility effects reduction
Visualization	Registration Motion correction

Enhanced Diffusion Weighted

eDWI	Multi b-value 3:1, Tetrahedral Smart NEX Inversion recovery for robust FatSat RTFA: Increases SNR by 50% and distortion reduction for accurate post processing when compared to dual spin echo
Visualization	ADC and eADC

One Touch Protocol

READYBrain	Automated multi-series, multi-plane prescription Combine with Auto Scan for one touch protocol In-line for Auto Post processing
------------	---

Dynamic Brain Function

	EPI-GE/SE T2* pulse sequence for DSC (Dynamic Susceptibility Contrast) Brain Perfusion
BrainSTAT Perfusion and Analysis	Blood flow Blood volume Mean transit time Time to peak parametric Fusion
BrainSTAT Arterial Input Function (AIF)	Manage tracer arrival differences due to patient flow dynamics Automatically or manually specify the AIF to normalize maps
Visualization	Brain STAT

Spectroscopy

PROBE PRESS	Concentrations of in-vivo metabolites evaluation Acquisition and display Reduced flip angles for lower min TE values Up to twice the SNR when compared to PROBE STEAM
Visualization	Brain Spectroscopy

Spine Imaging

2D/3D MERGE	High SNR T2* contrast Gray/white matter differentiation Foraminal detail
3D COSMIC	SSFP to emphasize T2 signal for improved contrast Nerve root and disc detail
Visualization	3D reformat MPR Volume segmentation Volume rendering

BodyWorks

The latest in torso imaging is delivered with volumetric imaging supporting advanced parallel imaging standard. Including, Snapshot imaging with optimized Single Shot FSE, 3D isotropic imaging for MRCP, Dynamic Imaging and Routine Volumetric imaging enabled with Motion Free navigation for post-contrast uses with high temporal resolution results. Motion correction is further enhanced with both the PB navigators as well as PROPELLER including T1-weighted results. Turbo class of acquisitions, streamlines the speed and enables higher quality results. Advanced processing is made one-touch with the new READYView on Console capabilities.

Volumetric Imaging

	Isotropic high resolution volumetric
3D Cube	Three-dimensional FSE (3D FSE), with flip angle modulation
	One sequence, reformat in all planes
	In- and out-of-phase
3D Dual Echo	Used to help identifying fatty infiltration, focal fatty sparing, liver lesions, and other conditions
	High spatial resolution
	3D reformat MPR
Visualization	Volume segmentation Volume rendering Auto-contour

Motion Correction

PROPELLER MB	Motion reduction
Auto Navigator	Free-breathing tracker
Respiratory Trigger	Free breathing bellows
Visualization	Registration Motion correction

Enhanced Diffusion Imaging

	Multi b-value, 3:1, Tetrahedral Smart NEX
eDWI	Inversion recovery for robust FatSat RTFA: Increases SNR by 50% and distortion reduction for accurate post processing when compared to dual spin echo

Enhanced Diffusion Imaging

	ADC and eADC
Visualization	Fusion

Dynamic Body Imaging

LAVA	SPGR Fast Liver Acquisition SPECIAL for robust fat suppression
LAVA Turbo	ARC acceleration for full organ coverage Shorter breath-holds
	Customizable phase delay for dynamic studies
Multi Phase Dynaplan	Series per phase Auto subtraction Pause after mask
Visualization	MR standard SER

Non-Invasive Non Contrast Biliary System – MRCP

3D frFSE MRCP	T2 Prep for background suppression Breath-hold and PB navigator
	T2-weighted, with sub second single slice acquisition High signal from fluids Good suppression of other tissues
2D SSFSE	Snapshot acquisition, motion artifacts virtually eliminated Thin slices and thick slab protocols Single breath-hold acquisition MIP post processing
2D FatSat FIESTA	Excellent contrast between ducts and gallbladder with surrounding anatomy FatSat for increased conspicuity
2D frFSE	T2-weighted High resolution Supplementary information for assessment of extra ductal masses
Visualization	3D Reformat MPR MIP & HD MIP

CVWorks

CVWorks provides GE's extensive coverage for the latest techniques enabling high performance CardioVascular imaging outcomes. Single breath-hold imaging for whole heart coverage are available from Morphology to Delayed enhancement. Enabling simplified generation of superb results including head-to-toe MRA support to single acquisition TOF and additional non-contrast imaging for flow.

Myocardium Delayed Enhancement

MDE PLUS

Single-Shot Myocardial Delayed Enhancement (SSH MDE)	Shorten breath-holds or free breathing for better patient tolerance Potential for reduced scan time Imaging arrhythmic patients Snapshot imaging for motion reduction
Adiabatic IR Pulse	Robust Myocardial Suppression Fat Suppression Adiabatic fat suppression pulse Improved characterization of enhancing tissue
MDE Plus: Phase Sensitive MDE (PSMDE)	Inversion Recovery FGRE sequence Phase-sensitive image reconstruction Consistent myocardial suppression, even with sub-optimal TI Improved contrast for myocardial Potential to shorten overall exam time

Single Breath Hold Whole Heart

Black Blood SSFSE	Difficult patients with irregular heartbeats or limited breath-hold capacity Potential to shorten exam times Shorten breath-holds for better patient tolerance Whole chest survey
-------------------	--

Viability Imaging

CINE IR	Multiphase FGRE Cine acquisition...quick assessment of optimal TI time for MDE Captures image contrast evolution at different TI times Adiabatic Inversion Recovery for uniform myocardial suppression Support both 1 RR and 2 RR mode
---------	---

Function

FIESTA	Fast Cine with retrospective gating Fast Card with prospective gating
--------	--

T2* Mapping

StarMap	T2* mapping compatible with gating for cardiac evaluation Non-invasive evaluation of the entire organ
READYView	R2 Star

Navigator Free-breathing Acquisition

Auto Navigator	Used with 3D IR Prepared FGRE or 3D FatSat FIESTA Free-breathing navigator diaphragm tracking
----------------	--

Flow Imaging

Flow Analysis*	Flow velocity and volume flow quantification Peak and average flow charts and graphics Automated contour detection Brain, chest and abdominal clinical applications
----------------	--

Contrast Enhancement Tracking

SmartPrep	Automated bolus tracking
Fluoro triggered	Real Time bolus tracking
Visualization	MIP & HD MIP

Peripheral Vascular Runoff

QuickStep	Multi-station, multi phase acquisition Automatically prescribes, acquires, and combines images from multiple stations Entire exam complete with no user intervention in as little as 7 minutes Auto subtraction
-----------	--

Non-contrast Vascular Imaging

2D Time of Flight (TOF)	Carotid bifurcation, venous anatomy, aortic arch, peripheral vessels
3D TOF	Circle of willis, intracranial vasculature, abdominal vasculature
3D TOF Multi Slab	Intracranial vasculature, carotid bifurcation, aortic arch, peripheral vessels, venous anatomy
2D Phase Contrast	Localizer, flow direction and velocity for intracranial and extracranial vasculature, portal or hepatic vein, quantitative measurement of flow velocity
3D Phase Contrast	Intracranial vasculature, renal arteries
Visualization	MIP & HD MIP
Inline Self Calibrating Phase Contrast	The feature provides an inline post-processing task that automatically corrects phase-contrast images from background phase error for MR flow imaging by using areas in the image that are known to have zero velocity.

*Optional

OrthoWorks

OrthoWorks delivers routine imaging that is not always a given. From motion correction to advanced volumetric imaging, GE's latest MSK techniques provide you with the contrasts you need for the basic imaging to enhanced cartilage imaging. And with multiple tissue suppression methods available, OrthoWorks enables the best of what can be achieved in a standard configuration.

High Resolution Imaging

FSE & frFSE	Intermediate PD, T1, T2-weighted imaging Compatible with FatSat, ASPIR, STIR and SPECIAL Gold standard for articular cartilage, cartilage ligaments, menisci and subcondral bone
-------------	--

Volumetric Imaging

3D Cube	PD, T1, T2, STIR Isotropic high resolution volumetric Three-dimensional FSE (3D FSE), with flip angle modulation One sequence, reformat in all planes 3D reformat MPR
Visualization	Volume segmentation Volume rendering

Motion Correction

PROPELLER MB	Multiple contrasts – T1, PD, T2, STIR Motion reduction
Visualization	Registration Motion correction

T2*-weighted Imaging

3D MERGE	High SNR T2* contrast Visualization of ligaments while adding soft tissue contrast Reduced chemical shift
3D COSMIC	Fast, high resolution volumetric imaging SSFP to emphasize T2 signal for improved contrast 3D reformat MPR
Visualization	Volume segmentation Volume rendering

Artifact Reduction Standard Sequence

MARS	FSE High bandwidth protocols High resolution, small FOV imaging
------	--

Fat Suppression

Chemical FatSat	Frequency selective fat saturation
STIR	Inversion recovery fat null point method
ASPIR	Solution for poor fat suppression due to B ₁ inhomogeneity
SPECIAL	Hybrid method between chemical FatSat and STIR
Spectral Spatial	Water excitation only

OncoWorks

OncoWorks delivers a complete platform for your needs in prostate, breast and radiation therapy planning. From the basic routine acquisitions to whole body imaging including volumetric and enhanced diffusion capabilities, GE enables superb linearity from the gradient platform and hardware performance. GE provides the necessary preset protocols to supply you with optimal imaging for your oncology needs that is further enhanced visualization capabilities so that your results can be a single click away.

Volumetric Imaging	
	PD, T1, T2, T1 FLAIR, T2 FLAIR and STIR
3D Cube	Isotropic high resolution volumetric Three-dimensional FSE (3D FSE), with flip angle modulation One sequence, reformat in all planes
3D Cube DIR	DIR, typically but not limited to CSF and white matter suppression
BRAVO T1	< 1 mm isotropic, MP-RAGE optional sequence of choice for functional data overlay
Visualization	3D reformat MPR Volume segmentation Volume rendering Auto-contour

Enhanced Diffusion Weighted	
eDWI	Multi b-value 3:1, Tetrahedral Smart NEX Inversion recovery for robust FatSat RTFA: Increases SNR by 50% and distortion reduction for accurate post processing when compared to dual spin echo
Visualization	ADC and eADC

Dynamic Imaging	
Multi-phase SPGR	SPGR dynamic fast acquisition SPECIAL for robust fat suppression
Visualization	MR standard SER

Whole Body Scanning	
FSE-IR/3D SPGR/DWI	Whole body imaging Multiple stations with large FOV Metastasis screening
Multi-station localizer	Consistent set-up Auto-table movement Auto-pasting Efficient work-flow

PaedWorks

PaedWorks is the GE solution to address your specific needs in paediatric imaging, from standard sequences supported with the latest in motion control for brain to toes. GE delivers standard acoustic reduction technologies and further addresses clinical needs for volumetric imaging, whole body imaging and enhanced diffusion results. The streamlined processing enables simplified one-click processing and visualization of complex results. PaedWorks covers your needs for all anatomies and provides optimized protocols and preset procedures.

Volumetric Imaging

	PD, T1, T2, T1 FLAIR, T2 FLAIR and STIR
3D Cube	Three-dimensional FSE (3D FSE), with flip angle modulation Isotropic high resolution volumetric One sequence, reformat in all planes
3D Cube DIR	DIR, typically but not limited to CSF and white matter suppression
BRAVO T1	< 1 mm isotropic, MP-RAGE optional sequence of choice for functional data overlay
3D Dual Echo	In- and out-of-phase used to help identifying fatty infiltration, focal fatty sparing, liver lesions, and other conditions High spatial resolution 3D reformat MPR
Visualization	Volume segmentation Volume rendering

Motion Correction

PROPELLER MB	Motion reduction
Auto Navigator	Free-breathing tracker
Respiratory Trigger	Free breathing bellows
Visualization	Registration Motion correction

One Touch Protocol

READYBrain	Automated multi series, multi plane prescription
(Not recommended for under 1 year of age)	Combine with auto scan for one touch protocol In-line for auto post processing

Dynamic Brain Function

	Blood flow
BrainSTAT	Blood volume
Perfusion and Analysis	Mean transit time Time to peak parametric Fusion
BrainSTAT	Manage tracer arrival differences due to patient flow dynamics
Arterial Input Function (AIF)	Automatically or manually specify the AIF to normalize maps
Visualization	BrainSTAT

Spectroscopy

	Concentrations of in-vivo metabolites evaluation
PROBE PRESS	Acquisition and display Reduced flip angles for lower min TE values Up to Twice the SNR when compared to PROBE STEAM
Visualization	Brain spectroscopy

Spine Imaging

	High SNR T2* contrast
2D/3D MERGE	Gray/white matter differentiation Foraminal detail
3D COSMIC	SSFP to emphasize T2 signal for improved contrast Nerve root and disc detail 3D reformat MPR
Visualization	Volume segmentation Volume rendering

SIGNA™ Works Features

HyperSense*

Going further than common sense

HyperSense is a Compressed Sensing acceleration technique based on sparse data sampling enabling faster imaging without the penalties commonly found with conventional parallel imaging.

HyperSense is intended to be used with volumetric acquisitions, it is combined with (ARC) parallel imaging delivering optimal signal to noise ratio with shorter acquisition times, extending the capabilities to additional sequences.

Benefits

- Increase productivity by reduced scan times
- Combined with ARC for higher acceleration factors
- Reduce breath hold time for dynamic imaging
- Drives higher spatial resolution for 3D imaging



HyperBand for EPI*

Quality and Speed Synchronized

HyperBand provides a reduction in scan time by simultaneously exciting multiple slices at multiple locations. It can lead to higher acceleration reduction factors when combined to other methods of parallel imaging. The benefits of HyperBand acceleration include enhancements on productivity and patient experience, increased anatomy coverage and higher resolution image acquisition.

Benefits

- Simultaneous excitation: multiple slices at multiple locations
- Acquisition time reduction without compromising post processing metrics
- More diffusion directions, number of slices or higher temporal resolution without extra scan time
- Shorter breath-holds
- Combine with ARC for higher acceleration factor
- Used for DWI, DTI, Gradient Echo EPI & fMRI imaging

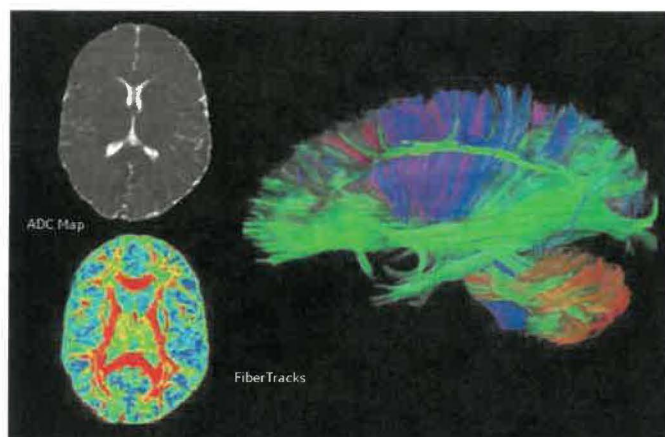

*Optional

**HyperSense expansions is not yet CE marked. Cannot be placed on the market or put into service until it has been made to comply with CE marking. Not available for sale in all regions.

SIGNA™Works Features (continued)

HyperCube*

Tailored 3D imaging that fits to perfection

Delivers small field of view organ specific volumetric imaging acquisition that can reduce artifacts originating from outside of the prescribed FOV. HyperCube can be applied with or without fat suppression using Flex or chemical saturation methods. Provides significant savings of imaging time without sacrificing contrast quality and it can be used across the entire body.

Benefits

- Significant scan time reduction while maintaining SNR efficiency
- High resolution small FOV isotropic volumetric imaging
- FLEX for large FOV robust fat suppression

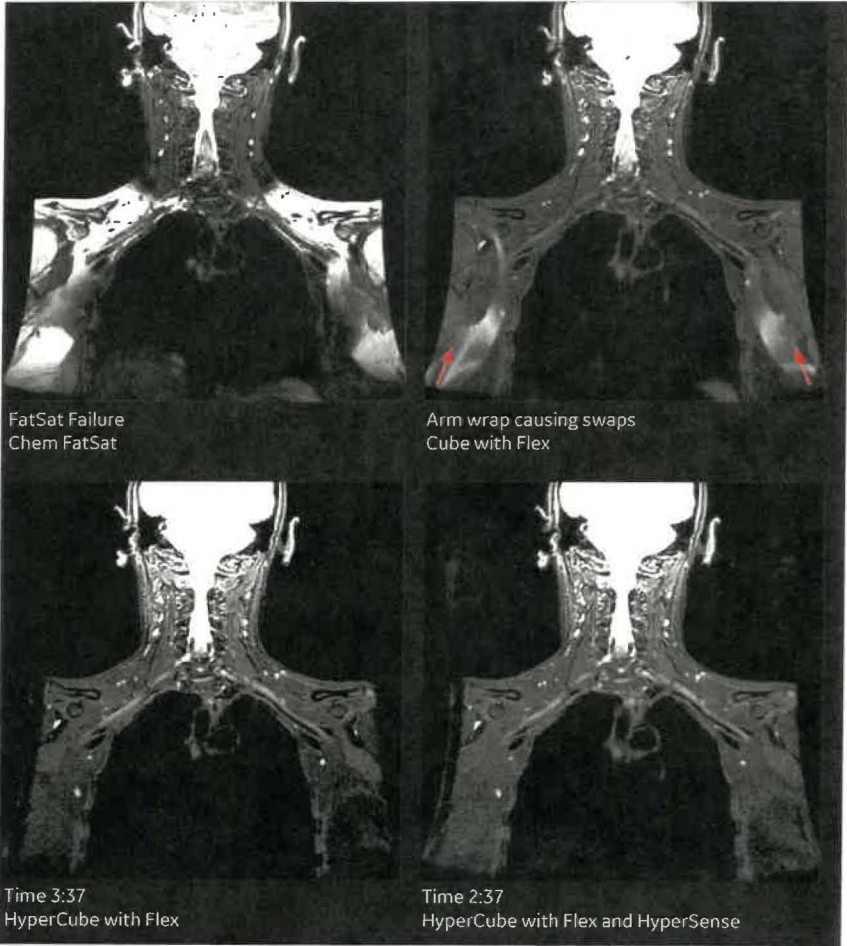

*Optional

SIGNA™ Works Features (continued)

Flex for Cube and FSE*

Unlimited solutions, consistent results

Flex uses a dual echo fat-water separation technology to provide robust and homogeneous fat suppressed images. Flex is compatible with ARC acceleration and can be used with a fast triple echo selection for significant scan time reduction. Enhanced uniformity and control of fat water swaps allow large field of view and off-center imaging where uniformity is a challenge. Delivering fast 2D and 3D acquisitions with reconstructed in-phase, out-of-phase, water and fat images, Flex represents productivity gains in all clinical areas.



Benefits

- 2D and 3D dual echo fat-water separation technique
- Uniform fat suppression for large FOV challenging offcenter anatomies
- Dixon-based, less sensitive to B_0 inhomogeneity
- Choice of single pass acquisition for significant scan time reduction
- Water, Fat, in-phase and out-of-phase images

MAGiC*

MAGiC (MAGnetic resonance image Compilation), enables one and done imaging capability by delivering multiple contrasts in a single scan. MAGiC utilizes a multi-delay, multi-echo acquisition. The data acquired is processed using a technique to generate T1, T2, PD and Inversion Recovery (IR) weighted images (including: T1 FLAIR, T2 FLAIR, STIR, Dual IR and PSIR weighted images), all at once, reducing scan time by up to 50% compared to acquiring all contrasts separately.** MAGiC generates all the different contrasts from the same acquisition, leading to enhanced image slice registration, owing to the absence of inter-acquisition patient movement. Because of the efficiency of MAGiC, the user has the flexibility to explore more advanced imaging, such as Spectroscopy***, Susceptibility Weighted Imaging*** etc., in the same time required to perform the routine exam without MAGiC. MAGiC

provides the user the ability to change the contrast of the images after acquisition. This is performed by adjusting the TR, TE, and/or TI parameters post-acquisition, to generate the specific contrast desired. MAGiC also enables users to generate parametric T1, T2, R1, R2, PD maps for further analysis of MRI acquisition data.



One MAGiC scan delivers six contrasts

Benefits

- Multiple contrasts a single scan
- Up to 50% faster than acquiring all contrasts separately*
- Ability to change the contrast after acquisition by modifying TR, TE and/or TI
- Enhanced image slice registration owing to the absence of inter-acquisition patient motion
- Parametric Maps: T1, T2, R1, R2, PD
- User Mask: manually mark regions of interest
- Auto ROI: after user selects a pixel, an ROI will be created from neighboring pixels with similar R1, R2 and PD
- Multiple layouts can be saved

*Optional

**Based on MAGiC clinical study of 109 patients from 6 separate institutions.

***Optional package (MAGiC in itself does not deliver advanced imaging)

It is recommended to acquire conventional T2 FLAIR images in addition to MAGiC

SIGNA™Works Features (continued)

MAGiC DWI*

MAGiC DWI generates multiple synthetic b-values from a single DWI scanned series allowing the user to view diffusion contrasts changes in real time after the acquisition. It delivers high b-values without stressing protocol parameters and resulting in shorter scan times without sacrificing contrast or anatomy coverage. Synthetic Diffusion is not limited to diffusion directionality or coil type.

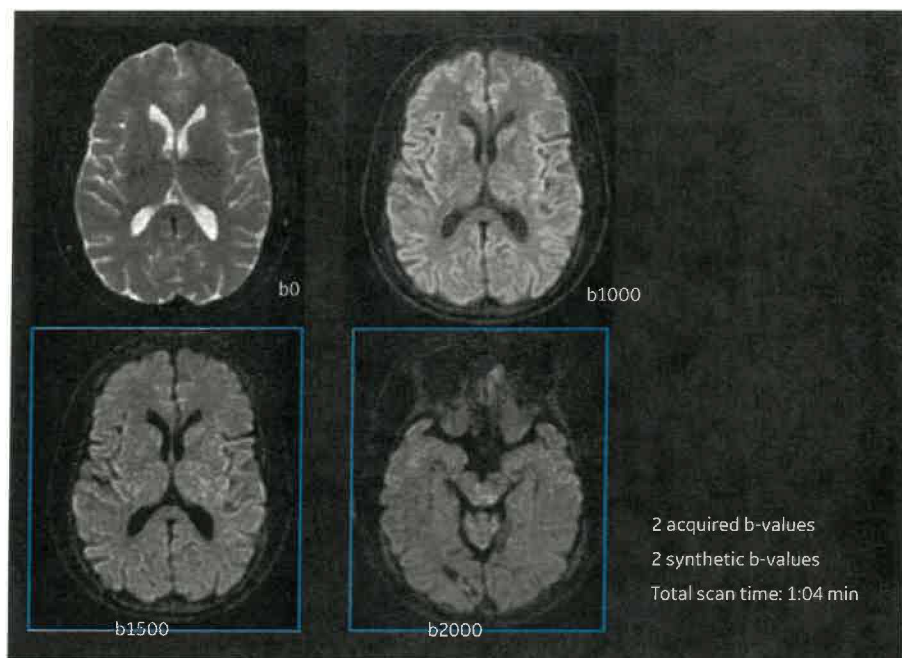

Benefits

- Multiple synthetic b-values from a single DWI scan
- High b-values in shorter scan times
- Compatible with FOCUS Diffusion

ViosWorks*

Confident Functional Accuracy

ViosWorks is a 3D cine-based acquisition that can be planned in any dimension and allows for velocity encoding in all directions to assess vascular flow. The acquisition delivers fast imaging with the use of Hyperkat acceleration including both, single and view sharing frames for higher temporal results. Provides high spatial resolution to enable visualization of flow through complex structures.

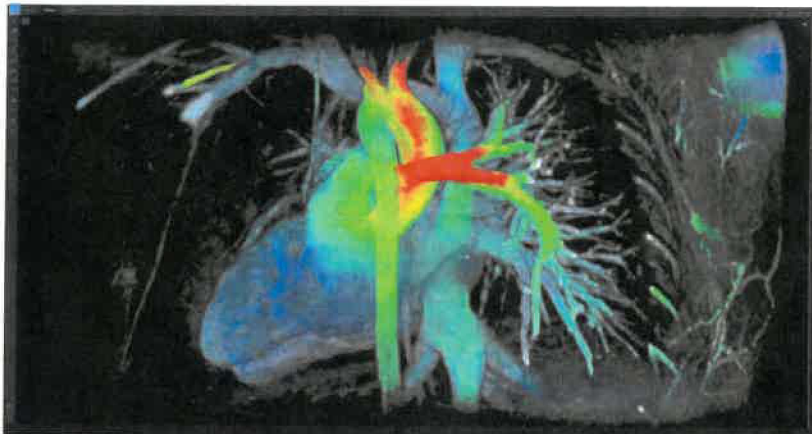

Benefits

- 3D cine acquisition in any dimension
- Free breathing whole chest coverage
- Allows velocity encoding in all directions
- Single and view sharing frames for higher temporal resolution
- Effortless workflow

*Optional

SIGNA™ Works Features (continued)

CardioMaps*

Achieving measurable benefits

CardioMaps is a powerful diagnostic technique that supports detection of cardiac pathologies by quantitative measurement of T1 and T2 relaxation times. The T1 Mapping acquisition includes automatic motion correction that compensates for cardiac and/or respiratory motion, providing reliable results. T1 Mapping offers two methods of acquisition: Inversion-recovery Look-Locker with FIESTA readout (MOLLI) for apparent T1 (T1*) measurements or saturation-recovery SMART1Map for true T1 measurements.

Benefits

- Quantitative measurement of T1 and T2 relaxation times
- Automatic motion correction for T1 Mapping
- Two methods of acquisition for T1* or true T1 measurements
- R² T1 mapping: R-squared to visualize a good fitting of the T1 mapping curve

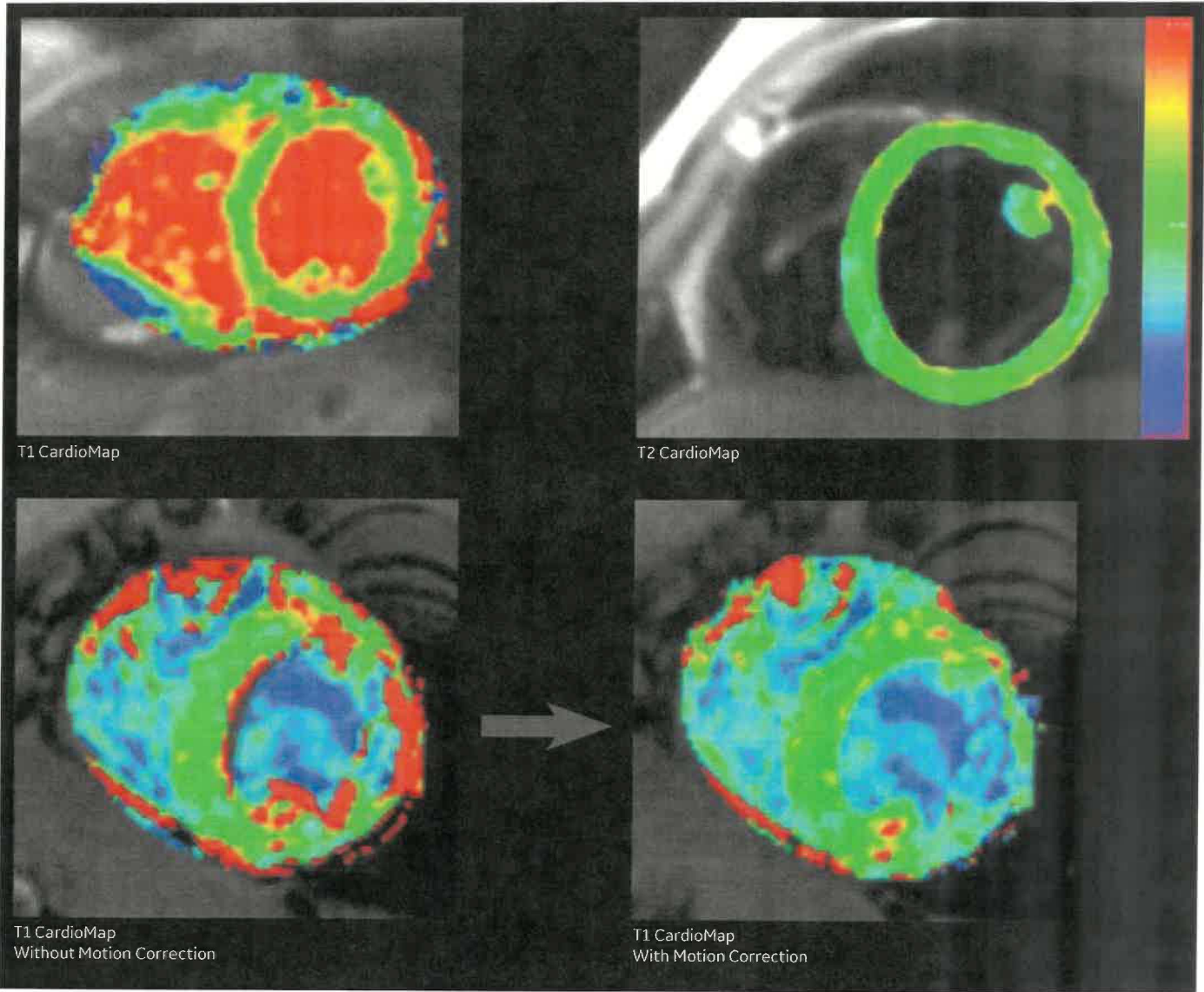

*Optional

SIGNA™ Works Features (continued)

PROGRES*

Resolving the limits of diffusion distortion

PROGRES is a series of optimizations that enhance the performance of diffusion imaging. It delivers:

- An automated distortion, motion and eddy current correction technique, based on an integrated reversed polarity gradient acquisition. Using a rigid affine registration, the technique outputs images with reduced susceptibility artifacts at no significant impact in overall scan time.
- Extended DTI capabilities allowing the selection and customization of up to 300 diffusion-encoding directions, resulting in more accurate diffusion tensor estimations.

Benefits

- Distortion and motion correction
- Up to 300 diffusion directions
- Improved image fusion

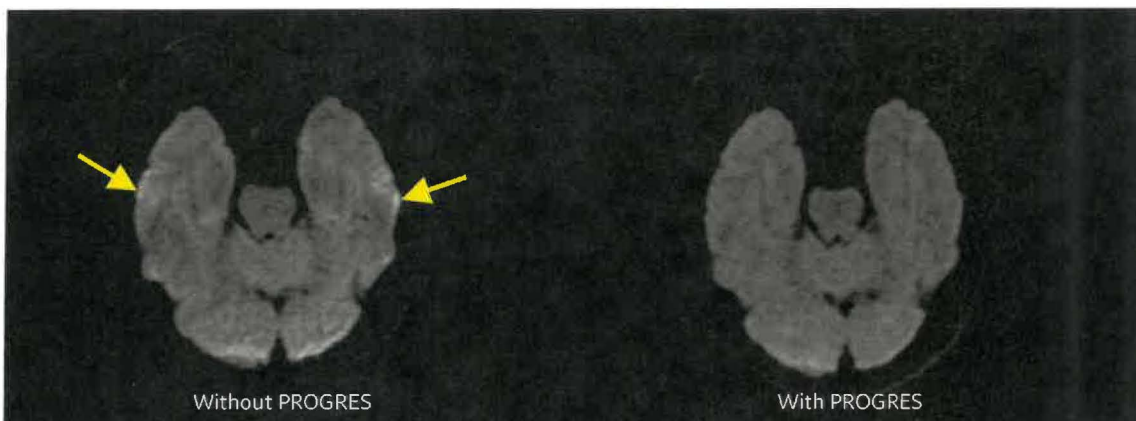

MUSE*

Resolving the limits of diffusion resolution

MUSE is a diffusion weighted and diffusion tensor technique that allows higher spatial resolution with reduced EPI-based distortions. MUSE implements a segmented readout approach along the phase encoding direction and utilizes a dedicated image reconstruction algorithm to mitigate shot-to-shot motion-induced phase errors inherent to multi-shot diffusion. The technique is compatible with Auto Navigators, cardiac and respiratory gating, as well as acceleration such as ARC and ASSET. MUSE is also compatible with fat sat and STIR.

Benefits

- High resolution diffusion imaging
- Reduced blurring and susceptibility artifacts
- Compatible with parallel imaging acceleration

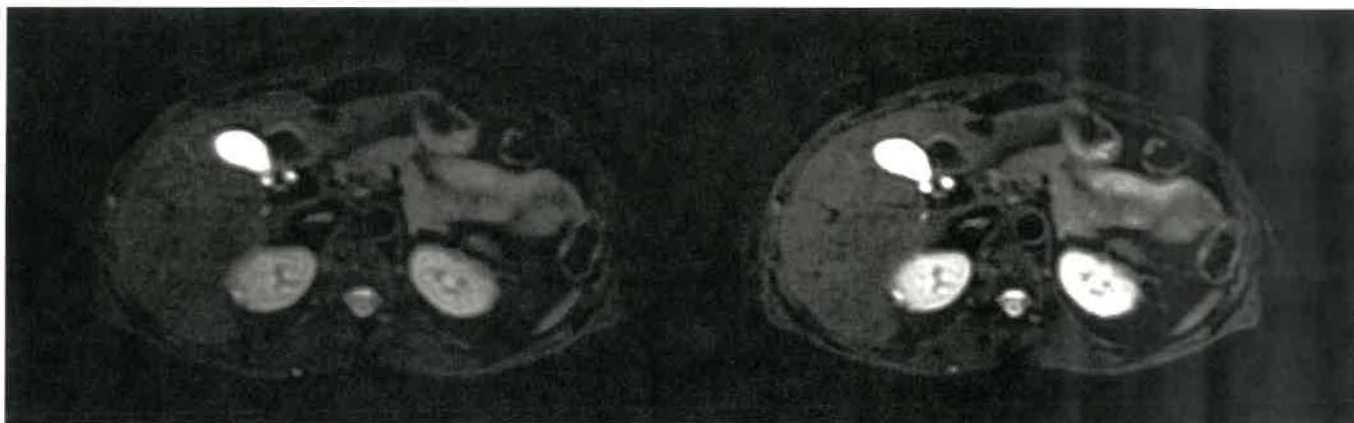

*Optional

Image Acquisition

Pulse Sequences

SPIN Echo	
SE FSE frFSE	Standard pulse sequences that are used to generate T1, Proton Density and T2 contrasts. The FSE technique enables long TR and long TE choices in reduced scan times. frFSE produces images with more T2 contribution allowing shorter TR values and resulting in shorter scan times when compared to FSE.
IR FSE-IR	IR techniques provide uniform suppression of tissues by applying an inversion pulse to null signal. FSE-IR reduces scan time while still achieving efficient tissue suppression FSE-IR with Water SAT pulse and manual adjustment of Center Frequency location to suppress silicon signal in breast imaging.
3D FSE 3D frFSE	Three-dimensional imaging acquisitions mostly used for T2-weighted contrast.
T1 FLAIR T2 FLAIR	T1 and T2 Fluid Attenuated Inversion Recovery (FLAIR) pulse sequences allow the suppression of signal from cerebrospinal fluid (CSF). This sequence provides contrast to differentiate white and gray matter to T1- and T2-weighted brain and spine imaging.
Double IR/Triple IR (Black Blood)	These pulse sequences are included to allow Black Blood imaging for studies of cardiac morphology (T1, T2, and PD). Triple IR adds fat suppression to Black Blood imaging. It also can be combined with Single Shot.
Double IR/Triple IR Single Shot	Single Shot Black Blood acquisitions allow larger volume acquisitions in fewer breath-holds.
SSFSE SSFSE-IR	Single Shot Fast Spin Echo is a technique that permits single slice data acquisition in less than one second. It is frequently used for MRCP studies in a single breath-hold and myelograms.
SSFSE Snapshot	The imaging efficiency of navigated/respiratory triggered SSFSE can be improved by imaging multiple slice locations per trigger event with SSFSE Snapshot.
3D MRCP	3D frFSE sequence that combined with the T2 Prep option provides improved background tissue suppression for MRCP exams.
T2 MAP*	T2 MAP is a multiple acquisition; multiple echoes FSE based method to obtain images that represent different T2 weighting values. The acquired data is processed to produce T2 color maps that are used for cartilage evaluation.
Cube FLAIR	Three-dimensional FSE (3D FSE), with flip angle modulation. You can easily reformat sub-millimeter isotropic volume data from a single Cube acquisition into any plane – without gaps, and with the same resolution as the native plane. T1 CUBE for blood saturation. 3D FSE technique that applies modified refocusing pulses for increased SNR. It is used to acquire isotropic data that can be reformatted in any plane.
Cube DIR	Cube DIR, double inversion recovery, is designed to achieve signal suppression from either gray or white matter and CSF.
Cube PROMO*	Prospective Motion correction is a real time 3D navigator based motion correction technique compatible with Cube T2, Cube DIR and Cube T2 FLAIR.
2D IDEAL*	2D FSE 3-point Dixon Water Fat Separation method that acquires 4 contrasts in one acquisition: Water, Fat, in-phase and out-of phase.
MAVRIC SL* HyperMAVRIC SL*	Multi-Spectral imaging technique is designed to reduce metal artifact near MR conditional implants. Improvements have been made with HyperMAVRIC SL feature to reduce scan time through a patient-specific metal analysis scan and allow functionalities, such as Variable flip angles, flow compensation, and No Phase Wrap. In addition to the T1, PD, and STIR contrasts, the sequence now also provides T2 weighting, and a B1-optimized STIR pulse.
3D ASL*	3D FSE based technique that uses a "labeling" pulse to quantify cerebral blood flow.

*Optional

Image Acquisition (continued)

Gradient Echo	
2D and 3D GRE/SPGR 3D GRE Dual Echo 2D and 3D FGRE/FSPGR 2D MFGRE (Multi Echo) 2D CINE GRE/SPGR	Gradient echo basic techniques offer a variety of possibilities to support imaging of all anatomies and can be acquired in 2D, 3D and Cine modes. The sequences generate T1 or T2 contrasts and support single, dual and multi echo acquisitions. 3D T1 weighted Fast Spoiled GRE for DCE (Dynamic Contrast Enhanced) perfusion.
2D and 3D MDE	Myocardial delayed enhancement is a technique used for tissue characterization to provide the assessment of myocardial perfusion.
PSMDE	Phase sensitive MDE increases the contrast between enhanced and normal tissue even with non-optimal inversion delay times.
SSMDE and SSPSMDE	MDE and PSMDE single shot based sequence that provides multi slice coverage with reduced breath-hold times.
2D and 3D FIESTA 2D FIESTA CINE 2D FatSat FIESTA 3D FIESTA-C	Fast imaging employing steady-state acquisition generates great contrast differentiation between tissues of low T2/T1 ratios and high T2/T1 ratios. Provides high SNR images in short acquisition times. FIESTA sequences offer benefits for Neuro, Cardiac and Abdominal imaging.
2D and 3D MERGE FGRE	T2* contrast technique that acquires multiple echoes at several different TE values.
2D Fastcard GRE/SPGR	Prospective gating sequence designed for breath-hold, aortic arch gated imaging.
2D FastCINE GRE/SPGR	Retrospective gating sequence, beneficial to cardiac wall motion studies, assessment of valve function and visualization of regurgitation and stenosis.
2D FGRE-ET* 2D FGRE-ET Real-time*	Fast gradient echo sequence combined with an EPI echo train for acquiring multiple phase encoding steps per TR. Used for first pass myocardial perfusion studies. Compatible with real time for cardiac planning and imaging uncooperative patients.
2D FGRE TC*	Fast Gradient Echo Time Course used for myocardium tissue evaluation on first pass studies which integrates automatic motion correction (MoCo) that compensates for cardiac and/or respiratory motion, providing reliable results.
2D Fast Spoiled Gradient Echo TC*	Fast Spoiled Gradient Echo Time Course used for myocardium tissue evaluation on first pass studies which integrates automatic motion correction (MoCo) that compensates for cardiac and/or respiratory motion, providing reliable results.
2D CINE-IR	FAST-CINE GRE IR Prep sequence is designed for myocardial viability studies. Supports TI time selection for consistent results.
2D Real-time FGRE/FIESTA	Free-breathing, Real-time planning sequence for whole heart coverage.
2D FIESTA TC*	2D FIESTA TC is used for myocardium tissue evaluation on first pass studies.
2D Tagging*	Fast Cine GRE based sequence for visualization of cardiac contractile function.
3D Heart*	3D FGRE/FIESTA navigated sequence for free breathing coronary artery imaging.
3D COSMIC	Coherent oscillatory state acquisition for the manipulation of imaging contrast is a modified FGRE sequence with steady-state free precession segmented acquisition for high SNR, high contrast spine imaging.
3D LAVA	Liver Acquisition with Volume Acceleration is a 3D SPGR technique designed to image the liver. SPECIAL is the fat suppression method applied and parallel imaging provides shorter scan times.

*Optional

Image Acquisition (continued)

Gradient Echo

3D LAVA Star**	LAVA Star is free breathing, single-phase, motion robust, 3D radial scan (stack of stars) technique. It is used for single phase (pre-contrast or delayed) imaging to produce worry-free, consistent image quality regardless of the patient's condition. LAVA Star employs radial in-plane trajectory to provide active motion compensation without navigators or bellows.
3D LAVA Flex*	3D FSPGR technique that acquires in-phase, out-of-phase, water only and fat only images in one acquisition. LAVA Flex uses ARC; a self calibrated 2D parallel imaging technique that allows acceleration in phase and slice direction.
3D Turbo LAVA 3D Turbo LAVA Flex*	LAVA Turbo provides a reduction of breath-hold timing for both LAVA and LAVA Flex acquisitions by as much as 20% reduction compared to conventional LAVA and LAVA Flex acquisitions. Available with respiratory triggering.
3D VIBRANT*	Simultaneous bilateral breast imaging technique in the Axial and Sagittal plane. SPECIAL and dual-shim volume capabilities provide homogeneous fat suppression.
3D VIBRANT Flex*	Acquires in-phase, out-of-phase, water only and fat only images in a single scan. It provides robust fat saturation and applies ARC, 2D self calibrated acceleration method for high spatial and temporal resolution images.
3D QuickStep	QuickStep is an automated multi-station run-off acquisition. This application automatically prescribes, acquires, and combines images from multiple stations for fast acquisition and simplified workflow.
3D TRICKS*	The time resolved imaging of Contrast KineticS (TRICKS) is a fast 3D dynamic acquisition for high temporal and spatial resolution MR angiography imaging (4D angio). Combined with elliptical-centric data sampling for consistent results.
3D SWAN*	High-resolution susceptibility weighting 3D multi echo gradient acquisition designed for small vessels visualization, as well as large vascular structures and iron or calcium deposits in the brain.
3D IDEAL*	IDEAL is a 3-point dixon water fat separation method that generates in-phase, out-of-phase, water images and fat images in one single scan. Provides homogeneous fat saturation for imaging for challenging anatomies as such as neck and spine.
3D IDEAL-IQ*	Whole liver 3D coverage in a single breath-hold, IDEAL IQ provides a non-invasive, quantitative assessment of triglyceride fat content in the liver that can aid in diagnosing steatosis.
StarMap*	StarMap is an acquisition and post processing technique that helps evaluate iron content in the heart and liver. Multiple echoes are acquired at different TE times for each pixel resulting in images that represent variations of T2* weighting. After the acquisition the images are post processed to generate color and grayscale T2* and R2* Maps.
DISCO* DISCO with FatSat	Differential sub-sampling with cartesian ordering, combine TRICKS and LAVA Flex technologies to acquire high temporal resolution 4D dynamic images with robust fat suppression and without compromising spatial resolution.
DISCO Star***	DISCO Star is a free-breathing, multi-phase, motion robust, 3D radial scan (stack of stars) technique. It is acquired in one continuous dynamic arterial phase to produce worry-free, consistent image quality regardless of the patient's condition. DISCO Star employs radial in-plane trajectory to provide active motion compensation without navigators or bellows.
MR Touch*	MR Touch is software and hardware application designed to measure relative tissue stiffness with MR. The acquisition uses a GRE based sequence that synchronizes induced vibrations to acquire a series of phase-contrast images over time.
MP-RAGE	MP-RAGE is a (3D) magnetization-prepared, rapid gradient-echo (MP-RAGE) sequence for structural brain imaging. The sequence captures high tissue contrast and provides high spatial resolution with whole brain coverage in short scan times.

*Optional

**LAVA Star is not yet CE marked. Cannot be placed on the market or put into service until it has been made to comply with CE marking. Not available for sale in all regions.

***DISCO Star is not yet CE marked. Cannot be placed on the market or put into service until it has been made to comply with CE marking. Not available for sale in all regions.

Image Acquisition (continued)

Vascular	
Inhance Inflow IR*	3D FIESTA based non-contrast-enhanced MR angiography technique that provides static background tissue and venous flow suppression for imaging arteries. It uses SPECIAL for uniform fat suppression and respiratory gating compatibility reduces respiratory motion artifacts during free-breathing renal exams.
Inhance 3D Velocity*	3D Phase Contrast based technique designed to acquire angiographic images in brain and renal arteries with robust background suppression in a short scan time. Respiratory triggering compatibility enabling abdominal angiography.
Inhance 2D Inflow*	Designed for imaging arteries that follow almost a straight path (i.e. femoral, popliteal, and carotid arteries) Inhance 2D Inflow acquires data during the systolic phase only. Compatible with Peripheral or Cardiac Gating and ASSET.
Inhance 3D Delta Flow*	3D FSE cardiac gated based non-contrast-enhanced MRA application designed for peripheral arterial imaging. This technique uses the differences between systolic and diastolic flow to help generate arterial signal contrast with robust background and venous suppression. ASSET compatibility provides shorter scan times.
2D TOF / 2D Gated TOF 2D Fast TOF FGRE/ SPGR 3D TOF 3D Fast TOF FGRE/ SPGR	2D TOF Imaging, 2D Gated TOF Imaging, 3D TOF Imaging and Enhanced 3D TOF Imaging are used for MR angiography imaging. Based on conventional gradient echo scanning, TOF imaging techniques rely primarily on flow-related enhancements to distinguish moving from stationary spins.
2D CINE Phase Contrast 2D FastCINE Phase Contrast	This pulse sequence is included specifically for studies of cardiac function. Through the use of retrospective gating, it allows full R-R coverage.
2D Phase Contrast 3D Phase Contrast	These techniques demonstrate flow velocities and directional properties in vessels and other moving fluids such as CSF and aortic flow.
EPI	
fMRI – BrainWave*	Real time acquisition, processing and display of functional imaging.
GRE-EPI SE-EPI FLAIR-EPI DW-EPI	Standard on all systems are gradient echo, spin echo, FLAIR, and diffusion weighted echo planar imaging. The EPI sequence supports single and multishot imaging, multi-phase imaging, as well as cardiac gating. Diffusion EPI produces images that can detect acute and hyper-acute stroke with b-value up to 10,000 s/mm ² , multi-NEX compatibility and the ability to generate ADC and T2-weighted TRACE images. The FLAIR option suppresses the CSF signal.
DTI*	DTI (Diffusion Tensor Imaging) is an EPI technique that acquires diffusion information in up to 300 different directions. The image contrast is based on the degree of diffusion anisotropy in the tissues. Post processing include Fractional Anisotropy (FA), Apparent Diffusion Coefficient (ADC), 2D directional maps and 3D fiber track models. Multi-shell DTI is available in clinical mode.
eDWI	Enhanced DWI (eDWI) provides high SNR diffusion images with short acquisition times. Supports Multi b-values with SMART NEX for variable NEX selection per B-value, "3 in 1" diffusion weighting to all three gradients simultaneously, tetrahedral selection with four different diffusion weighting combinations for shorter TE values and inversion recovery for fat signal reduction.
RTFA	The RTFA algorithm leads to a reduction in distortion of the diffusion image per diffusion axis. RTFA is designed to reduce image blurring and distortions typically associated with diffusion imaging throughout the body. RTFA also allows for increased utilization of single spin echo DWI which results in an increase in SNR by up to 50% compared to dual spin echo and, when combined with the improved resolution leads to an increase in image quality that can be utilized for image presentation, fusion and ADC map outputs.

*Optional

Image Acquisition (continued)

EPI	
RTCF	Real-Time Center Frequency (RTCF) option can be applied to DWI & DTI to enable using the optimal center frequency for each slice. This is intended to help improve fat suppression and signal drop off at areas of high B_0 inhomogeneity (off-isocenter, or area with high tissue susceptibility). It is also intended to reduce station-to-station misalignment in whole body diffusion imaging.
FOCUS DWI*	FOV Optimized & Constrained Undistorted Single-shot (FOCUS) DWI utilizes 2D selective excitation pulses to limit the prescribed phase encode FOV eliminating artifacts from motion, imaging back folding or unsuppressed tissue.

Spectroscopy	
PROBE-PRESS PROBE-STEAM*	PROBE Single-Voxel spectroscopy allows non-invasive evaluation of the relative concentrations of in-vivo metabolites. The sequence provides acquisition and display of volume localized, water-suppressed H1 spectra in single-voxel mode. The sequence consists of three slice selective RF pulses with crusher gradients. PRESS provides up to twice the SNR over STEAM.
PROBE-PRESS CSI (2D & 3D*)	PROBE 2D and 3D CSI enable simultaneous multi-voxel spectroscopic acquisitions in the brain. It is available with PRESS excitation to maximize SNR. Post processing includes automatically generated metabolic maps.
BREASE*	A TE-averaged PRESS (Point RESolved Spectroscopy) acquisition that provides the necessary biochemical information to help characterize breast tissue by assessing the presence of choline.
TEA-PRESS*	TEA PRESS is a TE-Averaged variant of the PRESS CSI pulse sequence. It collects spectra across a range of TE values and averages the results together to reduce the appearance of signals whose intensity varies as a function of TE. This allows signals whose intensity does not vary with TE to be accentuated in comparison. This is the underlying pulse sequence behind the BREASE application.

PROPELLER MB	
Silent T1, PD, T2, DWI, T1 FLAIR and T2 FLAIR PROPELLER MB*	PROPELLER MB is a multi-shot per blade sequence that uses a radial k-space filling pattern acquisition and a post processing correction algorithm to significantly reduce the effects of motion artifacts. PROPELLER MB is compatible with spatial and chemical Sat, ASPIR, STIR T1, PD and T2 Auto TI/TR and Navigator.
T1, PD and T2 PROPELLER MB	
T2 FLAIR PROPELLER MB	
T1 FLAIR PROPELLER MB	
DWI PROPELLER MB	
PROPELLER DUO	PROPELLER DUO is a FSE based technique that is less prone to distortions caused by field inhomogeneities. PROPELLER DUO has a comparable scan time when compared to conventional PROPELLER DWI, and has spatial sat and shim volume capability to further reduce distortions and reduce artifacts and improve image quality.

Silenz*	
Silenz T1 Silenz PD	Silenz is a 3D Zero-TE sequence comprising high bandwidth excitation and reduced gradient-switching radial acquisition that results in sound levels near ambient. Silenz has added flexibility in sequence prescription for anisotropic resolution enabling faster scan times and includes axial as well as oblique geometries.

Fat Suppression Technology	
FatSat	Applies a frequency selective saturation pulse at the frequency of fat before the imaging excitation pulse with the result being a signal measurement primarily from water.

*Optional

Image Acquisition (continued)

Fat Suppression Technology

STIR	STIR is an inversion recovery method that takes advantage of the T1 difference between water and fat to allow selection of the signal to suppress. In order to eliminate the signal from tissues, the TI time must match exactly the null point of the tissue that needs to be suppressed.
SPECIAL	Hybrid fat suppression technique that incorporates features from both the frequency selective FatSat and the STIR techniques by using a spectrally selective inversion pulse that inverts only the fat magnetization and leaves the only the water peak available for excitation.
Spectral Spatial	Method that applies selective pulses for water excitation only, while fat is left untouched, thereby producing no signal.
ASPIR	ASPIR method is a solution for poor fat suppression due to B_1 inhomogeneity. It is based on the frequency and the relaxation fat behaviors. Applies a spectrally selective adiabatic inversion pulse to excite the fat spins, imaging pulses are then applied after T1 null time when longitudinal magnetization of fat crosses zero. The disadvantages include sensitivity to B_0 and longer scan times.
IDEAL*	IDEAL is a 3-point Dixon technique that acquires three images at slightly different echo times to generate phase shifts between water and fat. The water/fat separation method is very efficient at providing homogeneous image quality. One acquisition provides four contrasts: water, fat, in-phase and out-of-phase images.
Flex*	Flex is a 2-point dixon technique delivering faster scan times compared to IDEAL 3-point dixon. It is based on the difference between fat and water resonance frequencies using two flexible echo times for further scan time reduction. One acquisition provides four contrasts: Water, Fat, in-phase and out-of-phase images.

Motion Correction Technology

PROPELLER MB	PROPELLER MB is a multi-shot per blade sequence that uses a radial k -space filling pattern acquisition and a post processing correction algorithm to significantly reduce the effects of motion artifacts. It is compatible with spatial and chemical Sat, ASPIR, STIR Auto TI/TR and navigator.
PROMO*	Prospective motion correction is a real time 3D navigator based motion correction technique compatible with Cube T2, Cube DIR, Cube T2 FLAIR, BRAVO and MPRAGE.
PB Navigators	Pencil beam navigators allow free breathing body and cardiac imaging by tracking the motion of the diaphragm. There are two navigator modes: navigator gating, uses a predefined signal acceptable range during the expiration and navigator triggering, uses signal to trigger data collection during the expiration.
Respiratory Trigger	Reduces breathing motion artifacts by synchronizing the acquisition with the respiratory cycle.
VCG	Vector cardiac gating reduces motion artifacts by synchronizing the acquisition with the cardiac cycle.
PG	Peripheral gating reduces motion artifacts caused by pulsating blood.

Acceleration Technology

Fractional Nex	Technique in which only partial k -space data is collected and the remaining data is estimated. It uses the phase conjugate symmetry reconstruction method, which only half of the phase encode steps are acquired for scan time reduction.
Fractional No Phase Wrap	Selectable on the user interface, Fractional No Phase Wrap allows you to adjust the phase FOV based upon the patient size and shape. Benefits include a physical view of NPW placement on the user interface, flexibility to manage SNR and Scan Time, and the power to scan only the area of interest within the determined FOV.
ASSET	Array spatial sensitivity encoding technique acquires under sampled multicoil data generating aliased images. These are post processed with coil sensitivity maps from the calibration scan to unfold the images.
ARC	Auto-calibrating reconstruction for cartesian imaging is a highly accelerated parallel imaging auto-calibrating method that doesn't require coil sensitivity maps. It enables smaller FOV prescriptions, less sensitivity to motion and prevents artifacts caused by coil calibration inaccuracies.

*Optional

Image Acquisition (continued)

Acceleration Technology	
HyperBand*	HyperBand enables scan time reduction by simultaneously exciting multiple slices at multiple locations. Reconstruction algorithms are then applied in order to separate the images acquired.
HyperSense**	HyperSense has been expanded to include T1 acquisitions including MP-RAGE & BRAVO for neuro imaging and LAVA, LAVA-Flex, DISCO and DISCO-Flex for body applications, and Vibrant for breast applications. In addition, HyperSense is now compatible with other 3D gradient echo sequences, such as MERGE, FIESTA and COSMIC.
Hyperkat*	HyperKat is an advanced k-t acceleration method that employs time-shifted sampling in data acquisition and exploits both spatial and temporal correlation with motion-adaptive time window selection in image reconstruction.
HyperCube*	Small FOV organ specific volumetric imaging acquisition method that enables outside phase FOV HyperCube signal suppression. The technique can help to reduce artifacts originated outside of the prescribed field of view.

Uniformity Correction Technology	
SCENIC	SCENIC (Surface Coil ENhancement for Imaging Clarity) is an advanced image uniformity correction that further improves upon the previous reFINE algorithm. By using the biased field, SCENIC utilizes B-Splines to iteratively determine the best sharpening algorithm. This results in improved contrast, reduced shading, and consistent sharpening when compared to conventional imaging filtering techniques
PURE	PURE corrects the field inhomogeneity by collecting a calibration scan from the (uniform) body coil and the (non-uniform) surface coil and calculating maps that relate the intensity correction values to the images.
deFINE	deFINE is an integrated in-line imaging processing method that provides edge enhancement and smoothing algorithms allowing the user to customize the image appearance.
reFINE	reFINE is an advanced image uniformity correction algorithm that addresses non-uniformity due to coil sensitivity profiles and dielectric shading effects. It reduces organ-motion induced misregistration artifacts, effects of low signal in dark regions and edge effects at tissue interfaces and borders. reFINE optimizes parameter settings for each application, coil, and body anatomy maximizing image uniformity results.

Noise Reduction Technology	
ART	Acoustic Noise Reduction Technology optimizes the gradient waveform to reduce the gradient noise without compromising performance.
Silenz*	Silenz is a 3D Zero-TE sequence comprising high bandwidth excitation and reduced gradientswitching radial acquisition that results in sound levels near ambient. Silenz has added flexibility in sequence prescription for anisotropic resolution enabling faster scan times and includes axial as well as oblique geometries.
Silent PROPELLER*	Silent PROPELLER gradient waveform approach reduces the acoustic noise level to less than 11dB above the ambient room noise.

Uniformity Correction Technology	
SCENIC	SCENIC (Surface Coil ENhancement for Imaging Clarity) is an advanced image uniformity correction that further improves upon the previous reFINE algorithm. By using the biased field, SCENIC utilizes B-Splines to iteratively determine the best sharpening algorithm. This results in improved contrast, reduced shading, and consistent sharpening when compared to conventional imaging filtering techniques.

*Optional

** HyperSense expansions is not yet CE marked. Cannot be placed on the market or put into service until it has been made to comply with CE marking. Not available for sale in all regions.

Image Acquisition (continued)

Uniformity Correction Technology

PURE	PURE corrects the field inhomogeneity by collecting a calibration scan from the (uniform) body coil and the (non-uniform) surface coil and calculating maps that relate the intensity correction values to the images.
deFINE	deFINE is an integrated in-line imaging processing method that provides edge enhancement and smoothing algorithms allowing the user to customize the image appearance.
reFINE	reFINE is an advanced image uniformity correction that consists of SCENIC and PURE that addresses non-uniformity due to coil sensitivity profiles and dielectric shading effects. It reduces organ-motion induced misregistration artifacts, effects of low signal in dark regions and edge effects at tissue interfaces and borders. Refine optimizes parameter settings for each application, coil, and body anatomy maximizing image uniformity results.

Noise Reduction Technology

ART	Acoustic Noise Reduction Technology optimizes the gradient waveform to reduce the gradient noise without compromising performance.
Silenz*	Silenz is a 3D Zero-TE sequence comprising high bandwidth excitation and reduced gradient switching radial acquisition that results in sound levels near ambient. Silenz has added flexibility in sequence prescription for anisotropic resolution enabling faster scan times and includes axial as well as oblique geometries.
Silent PROPELLER*	Silent PROPELLER gradient waveform approach reduces the acoustic noise level to less than 11dB above the ambient room noise.

Magnetization Transfer Contrast

Used to improve the Magnetization Transfer Imaging Option to improve contrast between blood flow and surrounding tissue in 3D TOF images, to augment post-contrast T1-weighted brain images, and to increase myelographic effect for improved disc and cord lesion visualization

Blood Saturation

Use Blood Suppression to obtain "black blood" cardiac images and reduce flow-related ghosting.

*Optional

RF Coils Suite

eXpress Table & Posterior Array

- Detachable table with embedded posterior array
- 100 cm S/I Coverage
- 40 Elements with dedicated spine configurations
- Head-first or feet-first
- Automatic coil mode selection
- Acceleration in all directions
- Patient-centric comfort pads



Comfort Pads

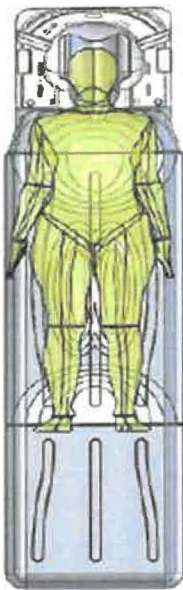

Petite Female

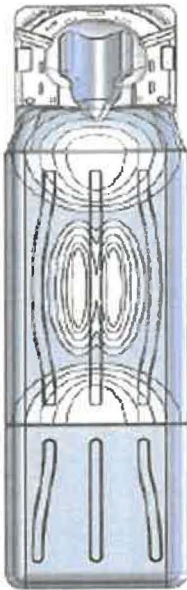

Very Large Male



RF Coils Suite (continued)

AIR™ Coils

1.5T 30ch AIR™ AA Coil*

The 30-channel AIR Anterior Array (AA) is the next generation anterior array coil that allows flexibility in any direction to conform to the patient's anatomy. Based on the innovative technologies behind the INCA conductor and the E-mode module, the 1.5T 30ch AIR AA provides superb SNR and acceleration performance, while improving the overall patient and user experience. The coil has been designed to adapt various patient shapes and sizes, with an ultra lightweight distribution of less than 0.35 grams/cm². The 1.5T 30ch AIR AA is a receive-only RF coil designed for use with GE 1.5T MRI systems to produce diagnostic images of general human anatomy, including extremities.



1.5T 30ch AIR AA

Elements	30
Maximum number of channels in the maximum FOV	45, when combined with the Posterior Array
Maximum number of channels in head-to-thighs imaging (S/I 145cm)	121, when combined with the Head-Neck Unit, Posterior Array and 2 nd AIR Anterior Array
Weight	1.8 kg (4 lbs) resting on patient, 2.7 kg (6 lbs) with the cable
R/L Coverage	60 cm
S/I Coverage	63 cm
Dimensions (W x L x H)	66 cm x 79 cm x 1.2 cm
Patient orientation	Head-first or feet-first

Coil combinations

Can be combined with the following coils:

- Head-Neck Unit
- Posterior Array
- AIR MP coils
- 2nd AIR Anterior Array
- Peripheral Vascular Peripheral Vascular

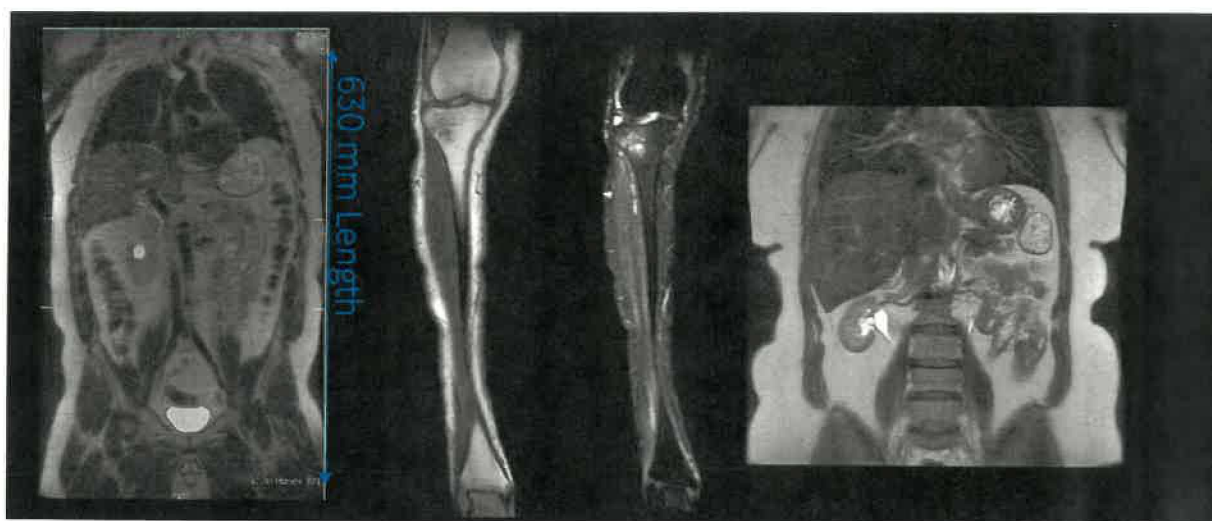

*The 1.5T 30ch AIR™ AA coil is not yet CE marked. Cannot be placed on the market or put into service until it has been made to comply with the Medical Device Directive.

RF Coils Suite (continued)

Head & Neck Unit



Head and Neck NV with Comfort Tilt

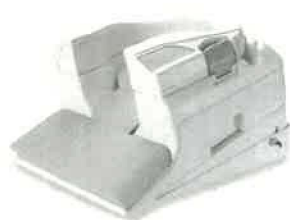

Head and Neck

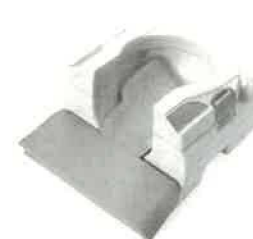

Cervical Open Face

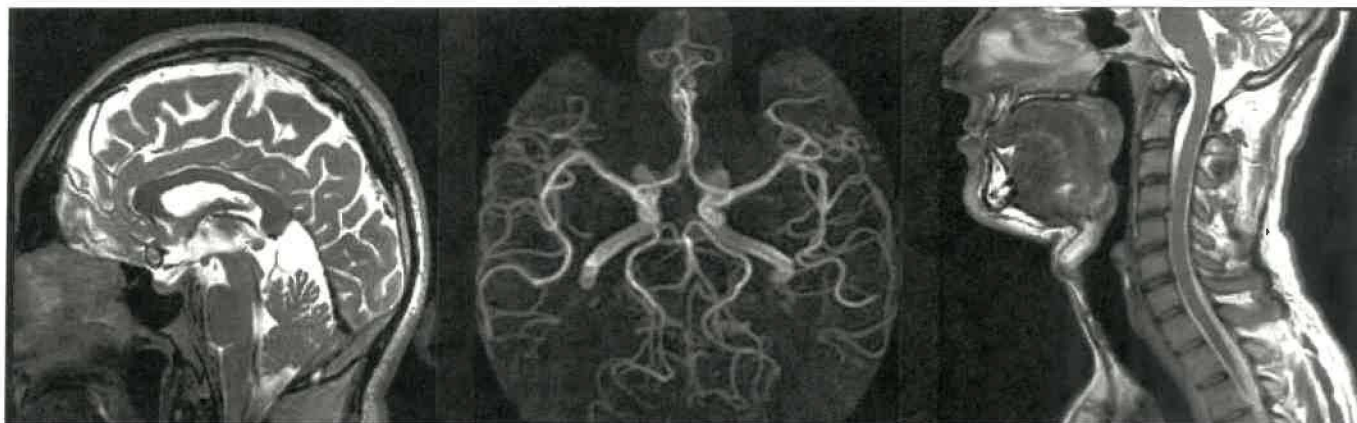

Head Neck Unit NV Specifications

Length	49.5 cm (19.5 in)
Width	38.8 cm (15.3 in)
Height	36.8 cm (23.9 in)
Weight of HNU base	5.0 kg (11 lbs)
Weight of Anterior Adapter	2.6 kg (5.8 lbs)
S/I Coverage	50 cm (19.7 in), when combined with the PA and AA
R/L Coverage in head mode	24 cm (9.4 in)
R/L Coverage for NV	50 cm (19.7 in), when combined with the PA and AA
Head-first or feet-first imaging	
Up to 28 elements in the FOV, when combined with the PA and AA	

Head Neck Unit Cervical Specifications

Length	49.5 cm (19.5 in)
Width	38.8 cm (15.3 in)
Height	33.6 cm (13.2 in)
Weight of Cervical Adapter	1.7 kg (3.7 lbs)
S/I Coverage	28 cm (11 in)
R/L Coverage	24 cm (9.4 in)
Head-first or feet-first imaging	
Up to 15 elements in the FOV, when combined with the PA and AA	

Head Neck Unit with Open Face Adapter Specifications

Length	49.5 cm (19.5 in)
Width	38.8 cm (15.3 in)
Height	25.7 cm (10.1 in)
Weight of Open Face Adapter	1.3 kg (2.8 lbs)
S/I Coverage	28 cm (11 in)
R/L Coverage	24 cm (9.4 in)
Head-first or feet-first imaging	
Up to 19 elements in the FOV, when combined with the PA	

RF Coils Suite (continued)

Anterior Array



Compatible with two AA coils

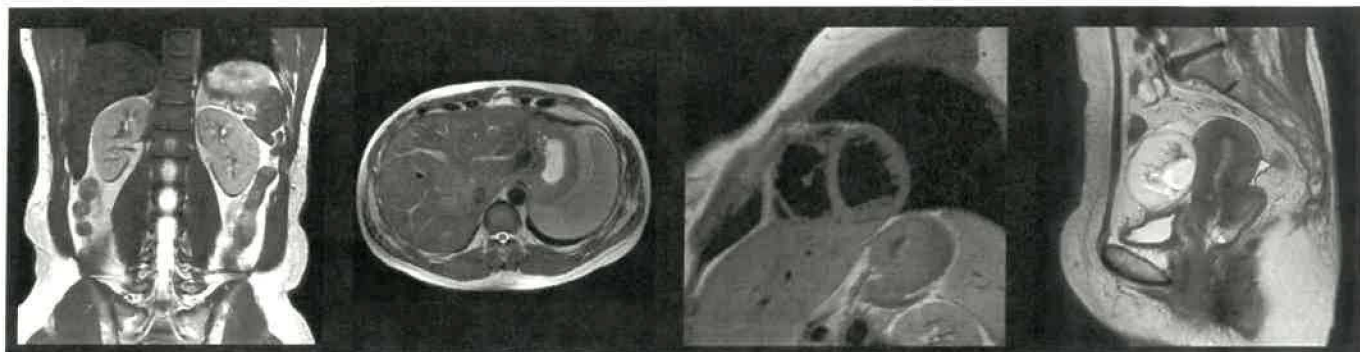

Anterior Array Specifications

Length	55.6 cm (21.9 in)
Width	67.4 cm (26.5 in)
Height	3.3 cm (1.3 in)
Weight	2.8 kg (6.16 lbs) resting on patient 4.1 kg (9.0 lbs) with cable
S/I Coverage	54 cm (21.3 in)
R/L Coverage	Full 50 cm (19.7 in) FOV of the system
Head-first or feet-first imaging	
Up to 36 elements in the FOV, when combined with the PA	

RF Coils Suite (continued)

Peripheral Vascular Array*



Optional Peripheral Vascular/Lower Extremity Array

Length	105 cm (41.3 in)
Width	2 nd station: 51.6 cm (20.3 in) 3 rd station: 64.2 cm (25.3 in)
Height	24.8 cm (9.8 in)
Weight	8.4 kg (18.6 lbs)
S/I Coverage	104 cm (49.9 in) overall 2 nd station: 52 cm (20.5 in) 3 rd station: 52 cm (20.5 in)
R/L Coverage	Full 50 cm (19.7 in) FOV of the system
Head-first or feet-first imaging	
Up to 35 elements in the FOV, when combined with the PA	

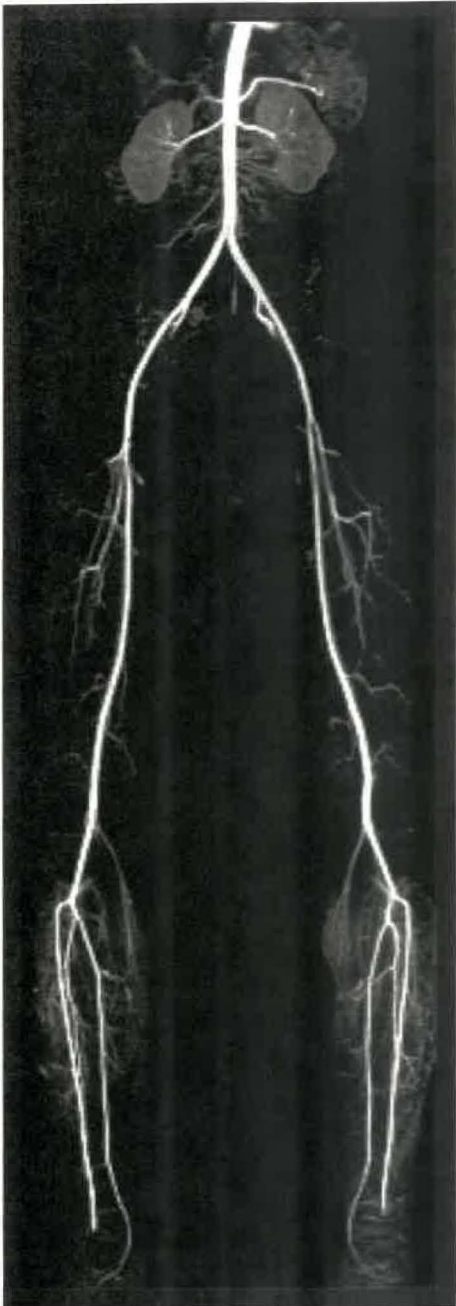

*Optional

RF Coils Suite (continued)

16-channel Flex Coils*



Knee and foot ankle positioner



GEM Flex Specifications

Coil	Dimensions (W x L)	Wrap Diameter	Elements	Weight
GEM Flex Large	23 cm x 70 cm	15.5 cm – 21.5 cm	16	1.0 kg
GEM Flex Medium	23 cm x 48 cm	11.5 cm – 15.5 cm	16	0.8 kg
GEM Flex Small	23 cm x 38 cm	9 cm – 12.5 cm	16	0.8 kg

32-channel Pediatric Coil Solution*

The 32-channel pediatric coil solution consists of a pediatric stabilizer positioner and interface that accommodates the Large Flex coil and the Medium Flex coil. Compatible with the Silent Suite.

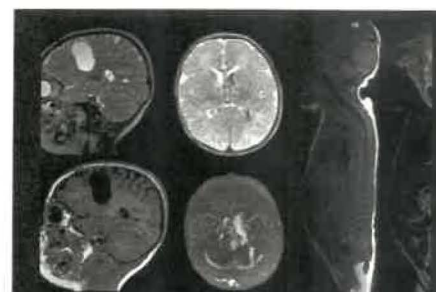
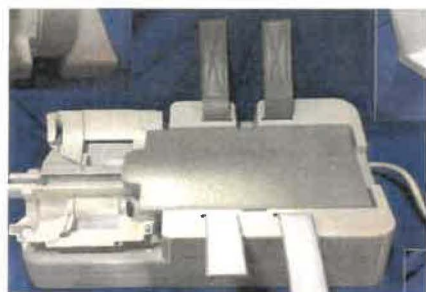

GEM Flex Specifications

Component	Coverage (W x L)	Wrap Diameter	Elements	Weight
GEM Flex Coil, Large	23 cm x 70 cm	15.5 cm – 21.5 cm	16	1.0 kg
GEM Flex Coil, Medium	23 cm x 48 cm	11.5 cm – 15.5 cm	16	0.8 kg

*Optional

RF Coils Suite (continued)

16-channel Shoulder Coil*

The Phased Array 16-channel Shoulder Coil consists of a baseplate that supports a posterior hard shell connected to an adjustable anterior plate, designed to better accommodate the patient anatomy. The baseplate and customized pad provide easy right - left adjustment for off-center positioning.



Benefits

- 16-channel phased array design
- Adjustable anterior plate for ease of positioning
- Parallel imaging compatible for speed



Specifications

Coil	Approximate dimensions (W x L x H)	Elements	Approximate Weight
16ch Shoulder	28 cm x 28 cm x 31.1 cm	16	3.9 kg

16-channel T/R Knee Coil*

The 16-channel Transmit Receive Phased Array Knee Coil is designed to acquire high SNR images of the knee. It is generously sized to effortlessly accommodate a wide range of the patient population. The two-part design provides a quick and efficient workflow. Offset imaging is fully supported with adjustable left-right coil positioning.

Benefits

- Transmit Receive 16-channel array design
- Large diameter to better accommodate anatomy
- High SNR for unique performance
- Parallel imaging compatible for speed



Specifications

Coil	Approximate dimensions (W x L x H)	Approximate Diameter	Elements	Approximate Weight
16ch T/R Knee	49.2 cm x 50.0 cm x 28.4 cm	15.5 cm	16	7.5 kg

*Optional

RF Coils Suite (continued)

8-channel Foot/Ankle Coil*

The Phased Array 8-channel Foot/Ankle Coil consists of a baseplate and a detachable hard shell coil that is designed for fast and easy positioning, comfortably accommodating the anatomy while providing proper immobilization.

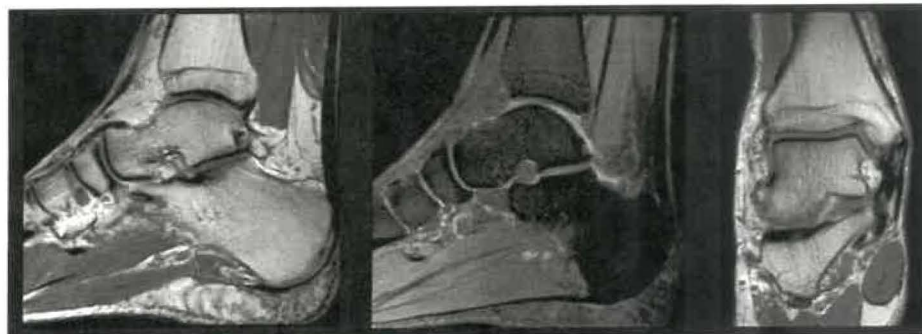

Benefits

- 8-channel dedicated foot and ankle phased array coil
- Optimized design to accommodate foot and ankle anatomy
- Slide and lock mechanism for easy positioning

Specifications

Coil	Approximate dimensions (W x L x H)	Elements	Approximate Weight
8ch Foot/Ankle	18 cm x 33.7 cm x 31.4 cm	8	3.1 kg
Baseplate	35.8 cm x 51.5 cm x 33.6 cm	-	3.8 kg

16-channel Shoulder Coil** (by NeoCoil)

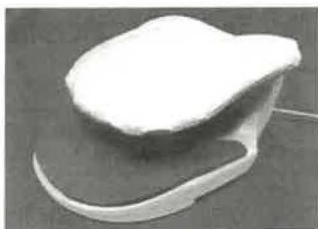

The Phased Array 16 channel Shoulder coil consists of a soft and light design anterior part and a hard shell posterior array to achieve higher SNR and better patient comfort. The simple coil design is allowing more flexible positioning.

Benefits

- 16 channel phased array design
- Flexible anterior part for ease of positioning as well as patient comfort.
- Parallel imaging compatible for speed.

Specifications

Coil	Approximate dimensions (W x L x H)	Elements	Approximate Weight
16ch Shoulder	28.2 cm x 35.3 cm x 18.2 cm	16	3.0 kg
Table Pad	52.0 cm x 52.0 cm x 5.7 cm		0.6 kg



*Optional

**Optional, 16ch Shoulder Coil (by NeoCoil) is not yet CE marked. Cannot be placed on the market or put into service until it has been made to comply with CE marking. Not available for sale in all regions.

RF Coils Suite (continued)

RF Coils and Arrays*

There are many optional receiver coils available to configure a SIGNA™ Artist 1.5T to meet specific applications requirements. The coils listed below are commercially available at the time of printing and are optional with the system. Please contact your local GE sales representative for the most current list.



Shoulder Phased Array*

- 3-channel phased-array coil
- Sleeve design
- Comprehensive shoulder imaging
- Homogeneous penetration of the humeral head and neck, rotator cuff, glenoid labrum, acromium process, and glenohumeral articular surfaces



Small Anterior Array*

- Up to 33 elements in the FOV when combined with PA for cardiac and body imaging
- Head first or feet first
- Optimized for parallel imaging
- Anterior coil dimensions (L x W x H) 45 cm x 40.5 cm x 4.5 cm (17.7 in x 15.9 in x 1.8 in)
- Anterior coil weight: 2.95 kg (6.5 lbs)



HD Breast Array*

- 8-channel 8-element phased-array design
- Optimized for uniformity, parallel imaging and VIBRANT
- Bilateral and unilateral breast imaging Biopsy plates available
- Coil dimensions: 50 cm x 54 cm x 25 cm (20 in x 21 in x 10 in)



16-channel T/R Hand Wrist Coil*

- 16-channel phased array coil, local transmit coil
- Prone or Supine positioning
- Optimized design for Fingers through wrist
- High SNR to enable high resolution images
- Parallel imaging compatible for speed
- Coil dimensions: 46 x 14 x 20 cm



1.5T Endorectal coil by Rapid

- Channel Count: 1 Ch Coil
- Dimensions: 9.7 x 2.5 x 1.7 cm
- Weight; 1 Kg (w/o cable)
- B1rms: 2.5uT
- Scan range: S/I: 8 cm, R/L: 1.6 cm
- Port Compatibillity: Any
- Head first or Feet first
- Coil Neck: 7.5 x 1.2 cm (Lengh x Diameter)
- House Dimension: 36 x 4.4 x 3.9 cm (Total)

*Optional

RF Coils Suite (continued)

16-channel Breast Coil with Biopsy*

The 16ch Breast Coil with Biopsy is a phased array coil for imaging structures of the breast, axilla and chest wall. The 16ch Breast Coil is a three part receive-only coil designed to provide high resolution imaging. It includes a coil support structure, patient support structure, biopsy components and comfort pads. The 16ch Breast Coil supports both diagnostic and biopsy imaging modalities while accommodating various anatomic shapes and sizes.

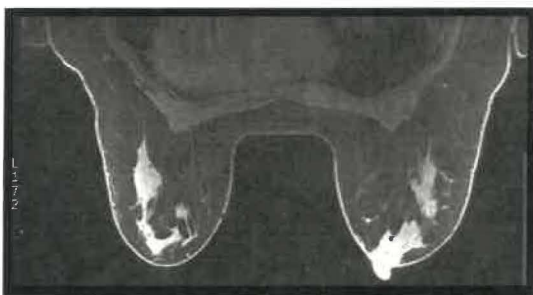

Benefits

- Each phased array is optimized to provide deep penetrating SNR and parallel imaging capabilities in axilla, breast and chest wall areas
- The support structures and pads are modular in nature to maximize the patient experience, giving the patient positioning support and comfort for the breast procedure

Specifications

Coil	Approximate dimensions (W x L x H)	Elements	Approximate Weight
16ch Breast Coil (no pads)	62 x 50 x 23 cm	-	5.6 kg
Lateral Array (each)	25 x 9 x 23 cm	5	0.8 kg
Biopsy Array (each)	25 x 9 x 17 cm	2	0.4 kg
Medial Array	36 x 15 x 18 cm	6 (3 Left, 3 Right)	1.2 kg
Biopsy Grid (each)	24 x 3 x 13 cm	-	0.1 kg

MR Enabled Therapy and Accessories

Radiation Oncology Options *

Combining the SIGNA™ Artist advanced imaging capabilities with the Radiation Oncology Options offering helps minimize potential registration errors between MR and CT within radiation treatment plans, for improved confidence in tumor targeting and preservation of healthy tissue. Additionally, seamless integration with AdvantageSim MDTM simulation software and integrated registration on the GE AW workstation allows MR images to be easily incorporated into the Radiation Oncology workflow.

Surgical Suite*

The Surgical Suite offering is an effective solution for incorporating MR imaging into your surgery center. Through seamless integration with surgical navigation systems, surgeons can retrieve archived images and fuse them with newly acquired intra operative MR images. This advanced technology can assist in real time surgical procedures.

MR-Guided Focused Ultrasound*

Your facility can offer a completely non-invasive treatment for uterine fibroids with the addition of an Exablate MR-guided Focused Ultrasound therapy table to your MR system, which has been used in 6,500 procedures worldwide.



SIGNA™ Flow

SIGNA™ Flow is designed to standardize and accelerate workflow for patient setup, exam prescription, scanning and post processing. eXpress Workflow can begin before the patient enters the magnet room and exams can be completed within a few mouse clicks - delivering quality and consistency for all patients and from all technologists. At the same time, eXpress Workflow maintains the flexibility needed to rapidly adapt and optimize exams for patient specific situations.

Exam Setup

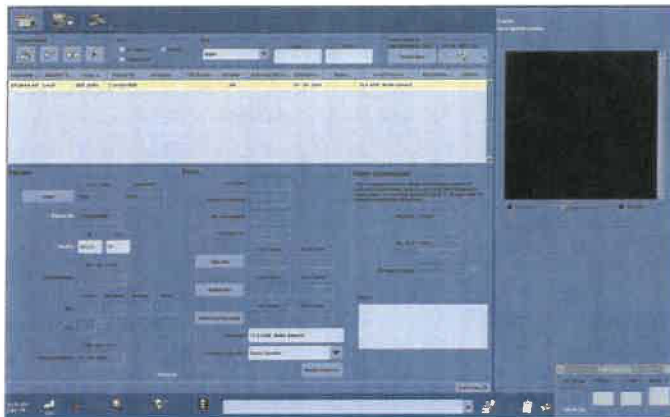

Modality Worklist

Automated and standardized rapid set up

- Allows the MR protocol to be selected and linked to the patient record in advance of the patient's arrival
- For sites with full DICOM connectivity, select the patient from the Modality Worklist, start a new session and view the relevant exam details on the in-room operator console
- Add critical patient information such as allergies, pre-medication, pregnancy status and history

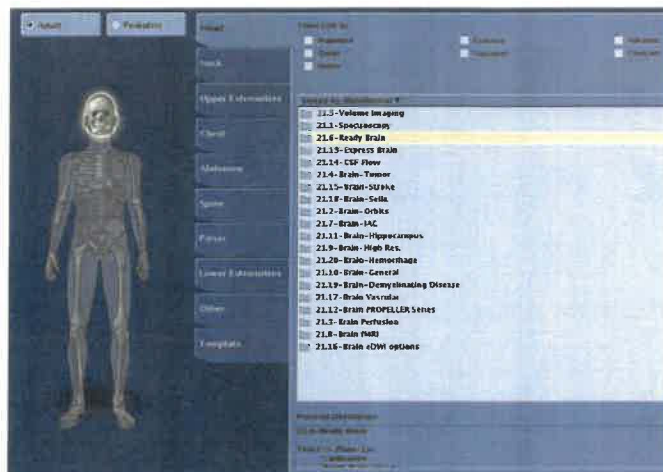

Protocol Tools

Search, select and one click to share

- Protocol Libraries: GE Optimized (preloaded protocols) and Site Authored (customized and saved)
- Protocols can be saved based on patient demographics, anatomy, scan type, or identification number for rapid search
- Commonly used protocols can be flagged for quick selection from the modality worklist
- One-click to share protoCopy – enables a complete exam protocol to be shared with the click of a mouse and provides a process for managing protocols across multiple systems as well as saving protocols for back up

AIRx™*

- AIR x™ (auto graphic Rx) – contains deep learning algorithms that automatically identify anatomical structures to prescribe slices for challenging setup planes for brain and knee. This workflow tool enables consistency and productivity improvements for routine and follow-up examinations and extends research/clinical capabilities for longitudinal quantification studies.
- Increases productivity by simplifying workflow steps, thus reducing prescription times
- Improves consistency and reduces slice positioning variation amongst different technologists
- Automatically adapts slice prescriptions to various patient anatomies and structures.

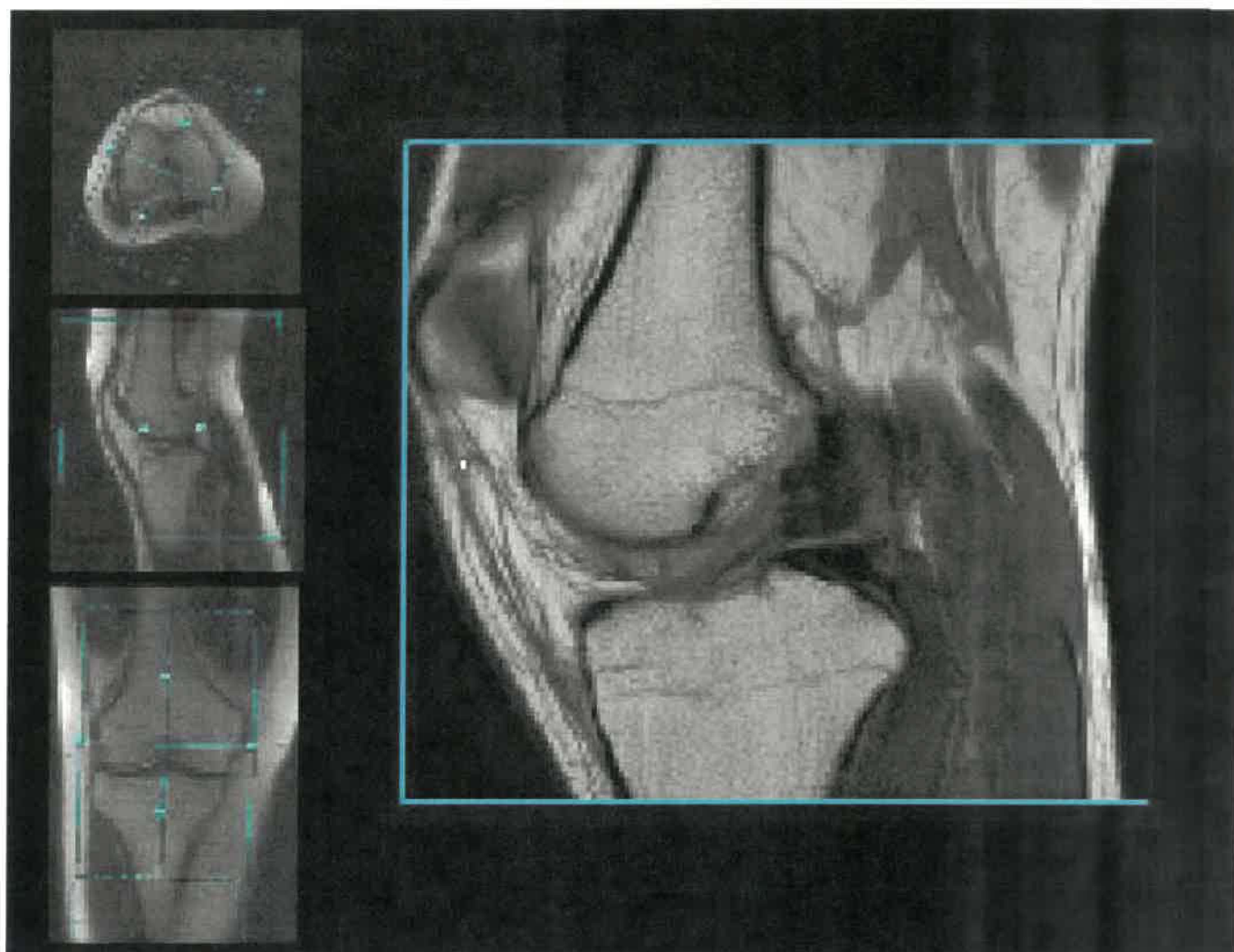
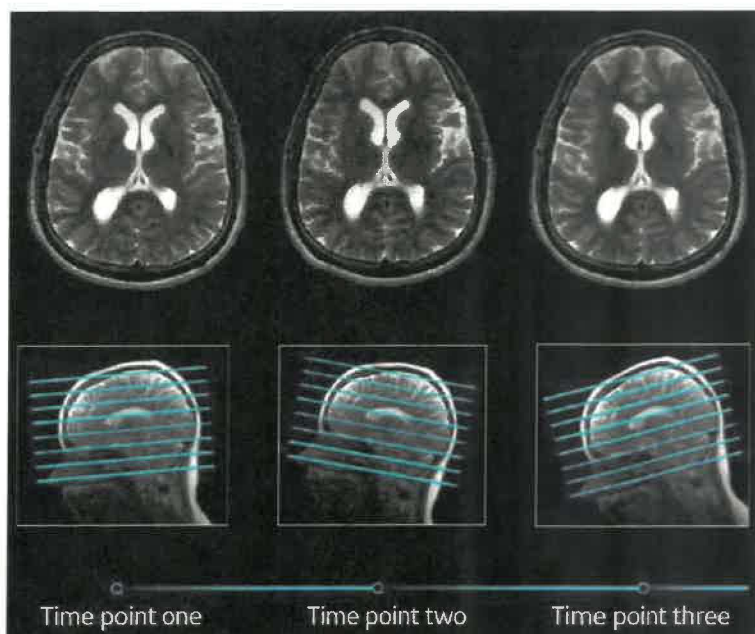

*Optional

AIR™ Recon DL**

Deep Learning based reconstruction to reduce noise, blurring and ringing artifacts for MR images. AIR™ Recon DL, a GE first deep-learning application for MR image reconstruction, is designed to improve signal-to-noise and image sharpness, enabling shorter scan times. It uses trained neural networks to remove noise and ringing from the reconstructed image. Compatible with most 2D applications, including diffusion weighted EPI.

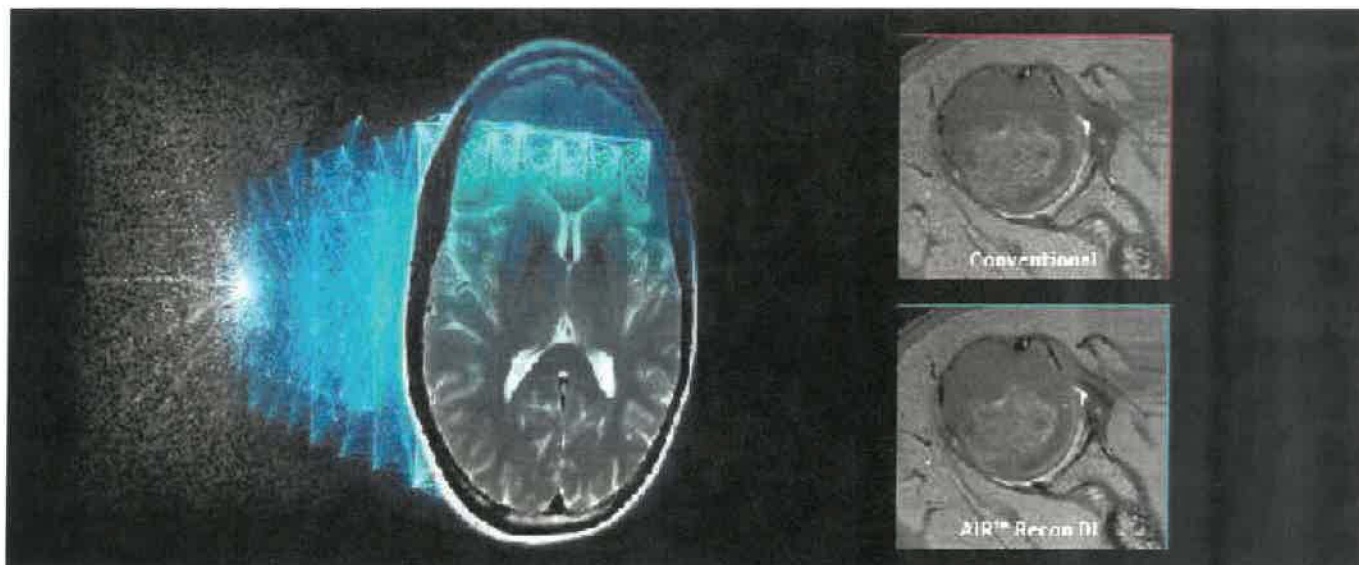

AIR™ Recon DL is a pioneering, deep-learning based reconstruction software that will change the way you think about MR imaging. Part of GE Healthcare's AIR™ family of products, which includes lightweight coil design and intelligent workflow applications, this software challenges the inherent trade-off between SNR, scan time and image resolution. AIR™ Recon DL is not a filter or a post-processing technique. It improves image quality at the foundational level because it's embedded directly in the reconstruction pipeline and is applied to raw data to remove noise and ringing artifacts.

AIR™ RECON DL AT A GLANCE

- Increases productivity by enabling shorter scan times
- Removes image noise and ringing by leveraging raw image data
- Delivers sharper and clearer TrueFidelity™ MR images
- Enables you to set your preferred SNR improvement level

oZTEo* MR bone imaging

GE's unique MR bone imaging application, oZTEo, is based on the zero echo time (ZTE) acquisition that is also used in the Silent Suite (Silenz) application. oZTEo complements the conventional soft tissue exam by providing cortical bone surface information. Automated grayscale inversion provides positive bone contrast that is more familiar to visualize for surgeons and clinicians. The ZTE sequence can be used for 3D isotropic resolution and adapts to the patient by providing an inherent motion insensitivity from a radial acquisition. oZTEo can be used with any surface coil that is compatible with SCENIC and includes protocols for common joints such as hip, shoulder, wrist, ankle and knee.



CT SCAN

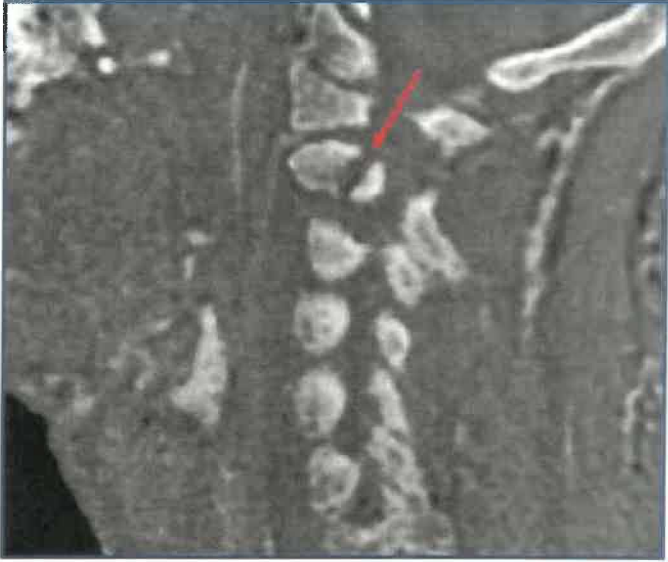

ZTE MRI



*optional, oZTEo is not yet CE marked. Cannot be placed on the market or put into service until it has been made to comply with CE marking. Not available for sale in all regions.

Patient Setup

eXpress Patient Table

Safety, Comfort and Efficiency

- Reduce patient transfers – transfer outside the magnet room directly to the eXpress table
- Accelerate emergency egress – can be undocked and removed by one user in under 30 seconds typically
- Automatic coil disconnect – in time sensitive situations the system coils are automatically disconnected
- Patient choice – feet-first or head-first positioning for all supported exams
- Reduce in-room patient setup and address privacy by fully preparing the patient and coils for an exam outside of the magnet room
- Integrate arm-boards and IV pole to support patient for transport
- Embedded posterior array and multiple high density surface coil connectors
- IntelliTouch landmarking sensors
- Compatible second table, prepare the next patient outside the magnet room while scanning the current patient



Express Patient Table

Configuration	Detachable and mobile
Minimum & Maximum Height	70 cm to 93 cm continuous*
Table Drive	Automated power-driven vertical Automated power-driven longitudinal
Longitudinal Speed	30 cm/sec (fast) and 0.5 cm/sec (slow)
Total Cradle Length	210.8 cm
Total Scanable Range	205 cm
Maximum Patient Weight for Scanning	227 kgs (500 lbs)
Maximum Patient Weight Detached and Mobile	227 kgs (500 lbs)
Maximum Lift Capacity	227 kgs (500 lbs)
Patient Transport Accessories	Self-storing non-ferrous IV pole Positioning Pads Immobilization Straps
Landmarking	Laser alignment with S/I and R/L alignment IntelliTouch touch sensors
Coil Connection Ports	2 high density, auto-sensing ports

*Minimum height (from floor) to install Head Coils at both ends of the table: 64.4cm

Patient Setup (continued)

AIR Touch™*

Intelligent coil localization and selection

Accelerate your scanning process the minute the patient gets on the table with AIR Touch™, a new workflow application that automates coil selection and landmarking. With AIR Touch™, you simply use IntelliTouch, GE's 1-touch landmarking tool, to activate an optimized set of coils that is selected based on the patient's anatomy. This advanced technology selects from numerous coil combinations such as the posterior array (PA) and flexible coils, to efficiently set up patients. With the anatomical-based protocol optimization, AIR Touch™ optimizes for the anatomy and the protocol parameters with a single touch, delivering a significant productivity gain from plan to scan. AIR Touch™ automatically integrates all calibration scans, providing uninterrupted workflow for the technologist. Further scan times savings are realized with Flexible No Phase Wrap (NPW) to scan only what you need while allowing you to focus on your patient, not the scanner.

- Dynamically generated coil configurations with elements activated to optimize image quality (coverage, uniformity and parallel imaging acceleration) for every scan
- Coil locations determined automatically
- Calibration scans seamlessly acquired without interrupting workflow
- Dramatically simplified coil selection UI; no need to touch it for most exams

IntelliTouch

Touch to Landmark

- IntelliTouch sensors for simplified non-laser patient landmarking
- With IntelliTouch technology, the user can touch to complete
 - Patient landmarking
 - Localizing to the surface coil for auto-coil selection
 - Move patient to scan
 - Start scanning (with AutoStart activated)
 - Acquire, process and network images

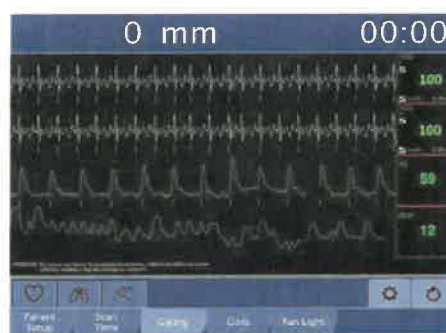
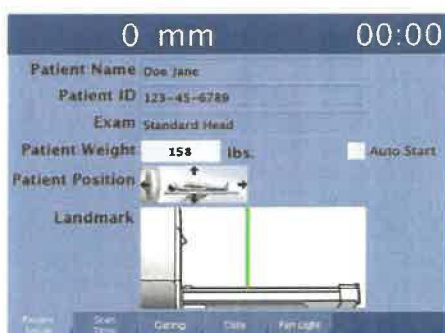
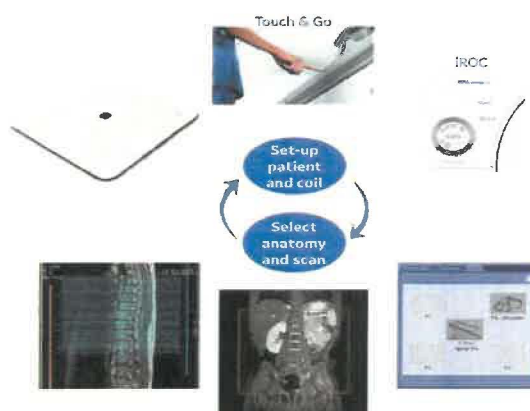

In-Room Operator Console and Control

Full Control from table side

From the in-room operator console and controls, the user can:

- Position the table
- Return the table to home
- Stop the table movement
- Control multiple levels of in-bore ventilation and lighting
- Display of patient name, ID, study description
- Display patient weight

- Display and entry of patient orientation and patient position
- Cardiac waveform display and ECG/EKG lead confirmation
- Gating control for trigger select, invert and reset
- Respiratory waveform display
- IntelliTouch technology landmarking
- AutoStart to initiate scanning of the selected protocol
- Display connected coils and coil status
- Display of table location and scan time remaining
- Activate Screen Saver

The in-room display also allows for the integration of third-party visualization tools.

In-line Processing & In-line Viewing

In-line Processing

Automated post processing

- Automated post processing of specific applications
- Automatic opening and loading to advanced visualization tools when appropriate
- Automated in-line processing can be stored within the protocol

Automatic Pasting and Saving

- MR Pasting: Combine images from separate acquisitions into a single series with MR Pasting. MR Pasting is an image analysis software package that facilitates the display and filming of multiple station MR data sets in the body applications (total spine, total body) as well as peripheral MR angiography data. MR Pasting will automatically register and combine multiple acquisition stations into a single image of covered anatomy
- AutPasting: automatic compute and save

3D ASL series*	Automatic compute and save
Diffusion Weighted series	Automatic compute and save
Diffusion tensor series*	Automatic compute and save
eDWI series	Automatic compute and save
Image filtering: A-E, deFINE	Automatic compute and save
Maximum/Minimum Intensity Projection	Automatic compute and save
Reformat to orthogonal plane	Automatic compute and save
T2 map for cartilage evaluation*	Automatic compute and save
3D Volume Viewer	Automatic load
BrainStat	Automatic load
FiberTrak*	Automatic load
Image Fusion	Automatic load
Interactive Vascular Imaging	Automatic load
Pasting	Automatic load

In-line Viewing

Enhanced Visualization

In-line viewing allows the user to seamlessly and conveniently view, compare, and analyze images (during scan progress). The user simply selects the series, or multiple series, to view from the workflow manager, and the images are displayed along with the image display tools.

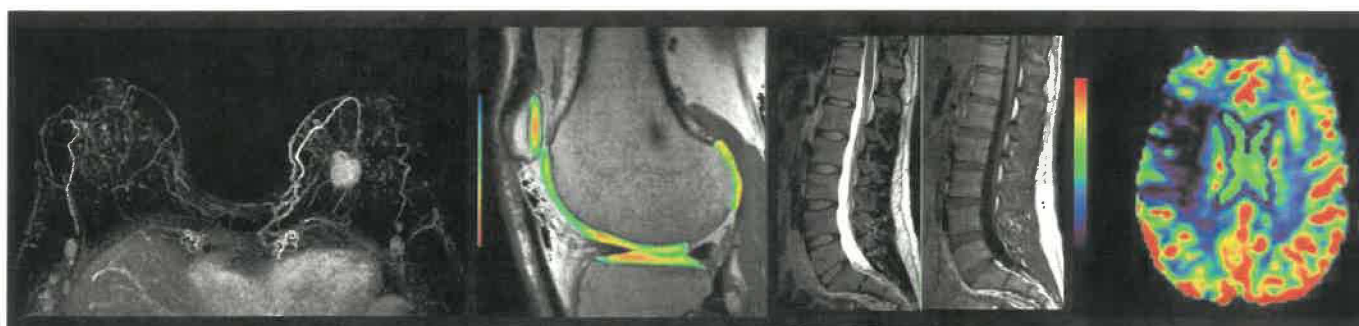

*Optional

Scanning

Workflow Manager

Linking and Auto Functions

AutoStart	Automatically initiates scanning of the selected protocol upon closure of the scan room door.
AutoCoil	Automatically determines the optimum coil elements to activate for scanning. If the prescribed field-of-view changes, AutoCoil automatically adjust the selection. The user has the option to review and edit the selection.
AutoScan	Automatically scans the prescribed series without user interaction. For series requiring a contrast injection, the Workflow Manager will pause and await user interaction.
Auto-calibration	For acquisitions that utilize ASSET parallel imaging or PURE surface coil intensity correction, Auto-Cal will prescribe and acquire a calibration scan based on the prescribed imaging volume.
AutoVoice	Delivers user selected, pre-recorded instructions to the patient at defined points in the acquisition to help ensure exam consistency. AutoVoice includes instructions in 14 languages and also allows the user to create and save unique instructions for specific local needs.
PB Navigators	Enable free-breathing body imaging for patients unable to breath-hold. The diaphragm tracker pulse automatically places and updates to streamline workflow and eliminate the setup time associated with respiratory triggering. Auto Navigators can be used with a broad range of imaging techniques including dynamic contrast enhanced T1-weighted imaging.
READYBrain	Automates localizer acquisition, scan plane prescription, scanning, and post processing for brain exams. READYBrain automatically calculates the mid-sagittal plane and determines the AC-PC line/OM line for 2D/3D prescription as well as corrects for extreme (>45 degree) rotation.
QuickSTEP	Automatically prescribes, acquires, and combines images from multiple stations. QuickSTEP acquires mask datasets and then secondary datasets from multiple stations (same locations), and automatically subtracts the mask datasets from the secondary datasets to create one subtracted series.
eXpress Prescan 2.0	Reduces pre-scan time for FSE-based techniques by up to 40% with a new calibration algorithm that reduces pre-scan time and consequently overall exam time.
Pause and Resume	Allows the user to pause a scan in progress, to respond to a patient need, and then resume mid-scan (without repeating scan).

Visualization

READYView on MR Operator Console

Integrated Post Processing & Advanced Visualization

READYView is an image analysis software that allows the user to process dynamic or functional volumetric data and to generate maps that display changes in image intensity over time, echo time, b-value (diffusion imaging), frequency (spectroscopy). The combination of acquired images, reconstructed images, calculated parametric images, tissue segmentation, annotations and measurement performed by the clinician allows multiparametric analysis and may provide clinically relevant information for diagnosis.

- Automatically selects the most relevant post processing protocol*
- Provides guided workflow and general assistance for the processing algorithms
- Multiparametric protocols selection for Brain, Breast, Liver, Knee and Pelvis studies when two or more functional series are present
- MR general review enables efficient reading of multi-contrast exams based on Smart Layout Technology
- One-click – to select and process functional data
- One-click – to save all generated parametric images
- One-click – to save and restore the state of processed images at any stage
- One ROI – display all multi-parametric images and get all related functional values from a single ROI
- Export – display and export ROI statistics from the summary table
- Export graph values as csv files
- Customize workflows with adjustable layouts, personalized parameter settings, and custom review steps

Benefits

- 3D ROI
- 3D Reformat MPR
- Auto-contour
- Distortion Correction
- Fusion & Registration
- MIP & HD MIP
- Motion Correction
- Multiparametric protocols
- Multiple graphics display
- Ratio AB/CD
- Reformat & Graphview
- Subtraction
- Volume Rendering
- Volume segmentation ROI

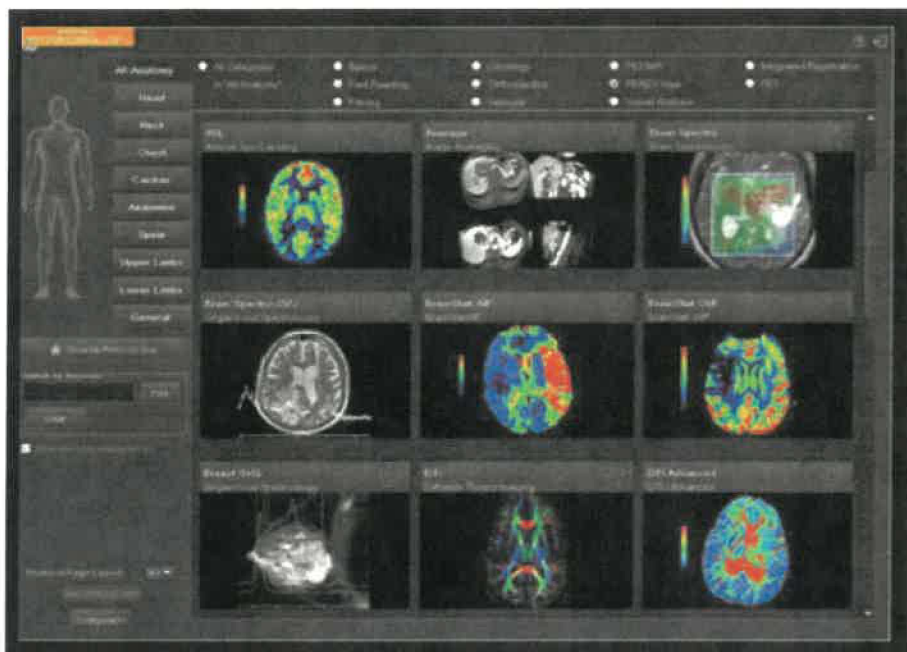

* When only one protocol is compatible with the selected data, the access is made through the One-Touch mode. If more than one protocol is compatible, the Protocol page opens for user selection.

READYView

Standard Protocols

READYView One-Touch

Protocols uses display intelligence with pulse sequence, image contrast and scan plane recognition to enable direct access between a unique post processing that is associated with the series selection.

One-Touch ADC and eADC

Provide algorithms to process DWI images to generate ADC maps and eADC maps to eliminate T2 "shine through" in the isotropic (trace) DWI.

One-Touch ASL*

ASL READYView has algorithms that calculate Cerebral Blood Flow maps from a 3D ASL series. ASL acquisition is a non-invasive, one-click application that allows whole brain CBF measurements.

Ready View Spectroscopy*

The READY View MR spectroscopy protocols are used to display functional maps for metabolites and metabolite ratios in the brain and prostate.

One-Touch Brain*

The READYView Brain protocols are used to display functional maps for metabolites and metabolite ratios in the brain.

One-Touch MR-Touch*

READYView MR-Touch is a post process of an MR-Touch acquisition, which is a Phase Contrast (PC) application that generates an image contrast related to the shear stiffness of soft tissue. An algorithm is used to derive a relative stiffness map (Elastogram) and wave images from the phase images.

One-Touch T2 MAP*

The READYView T2 Map protocol post processes data sets acquired using the T2 Map (CartiGram) application. The T2 Map acquisition is displayed in READYView, where the T2 relaxation time color map is coded to capture T2 values from the TE range of the acquired images.

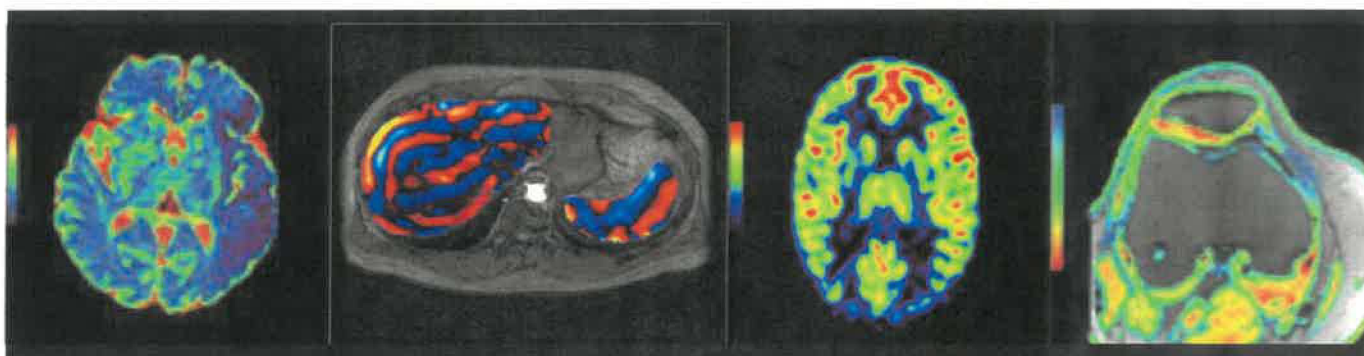

READYView (continued)

Integrated Registration provides you with the capability to align and fuse two volumetric acquisitions from either the same or different acquisition modalities. Multiple 2D and 3D fusion capabilities.

The Integrated Registration application automatically detects the series that are the best candidates for registration based on the data set attributes and the use case. After the Reference (i.e., fixed) and Registered data sets are identified, the applicable registration methods will be automatically detected.

After the automatic registration is done, you can either directly accept automatic setup or validate it visually.

If you are still not satisfied with the result of the registration, it can be adjusted manually by translation or rotation, placing common anatomical landmarks, or a Region Of Interest (ROI) on the Registered dataset, where the registration should be performed, can be defined; the regions outside the ROI are ignored by the registration process.

BrainStat

BrainStat is an MR Time Course imaging READYView protocol that provides accurate spatial resolution for brain tissue viability given by hemodynamic parameters: BV, BF, TTP, MTT (SVD), BAT, Tmax. These hemodynamic parameters can provide unique information on tissue changes and improve delineation of vascular-deficient or vascular-rich regions in normal and abnormal anatomy.

MR Standard

MR Standard is a time course protocol. The READYView MR Standard is a time course protocol that can be used to create the following maps: enhancement integral (negative and positive), time to peak, mean time to enhance, maximum slope of increase, maximum slope of decrease.

SER

SER is a time course protocol for analyzing T1-contrast changes. The READYView SER protocol can be used to create the following maps: Positive enhancement integral, signal enhancement ratio and maximum slope of increase.

FiberTrak*

FiberTrak is designed for the advanced analysis of MR images acquired with a DTI technique. It allows for processing of isotropic, ADC and FA maps among other options. The FiberTrak option augments this functionality to allow DTI processing to create: 2D color orientation maps, 2D color eigenvector maps and 3D tractography maps.

fMRI*

Functional imaging or BOLD provides fMRI analysis using the correlation coefficient algorithm to analyze an image set. Neuronal activity of either motor or cognitive functions can be mapped by fMRI through changes in signal intensity. The resulting functional maps can be used for mapping the motor cortex and higher cognitive regions of the brain.

R2 Star*

The R2 Star feature uses water proton transverse relaxation rates (R2) technique. It provides parametric maps for R2* (Hz) and T2* (ms). The R2* values vary with tissue characteristics such as iron concentration.

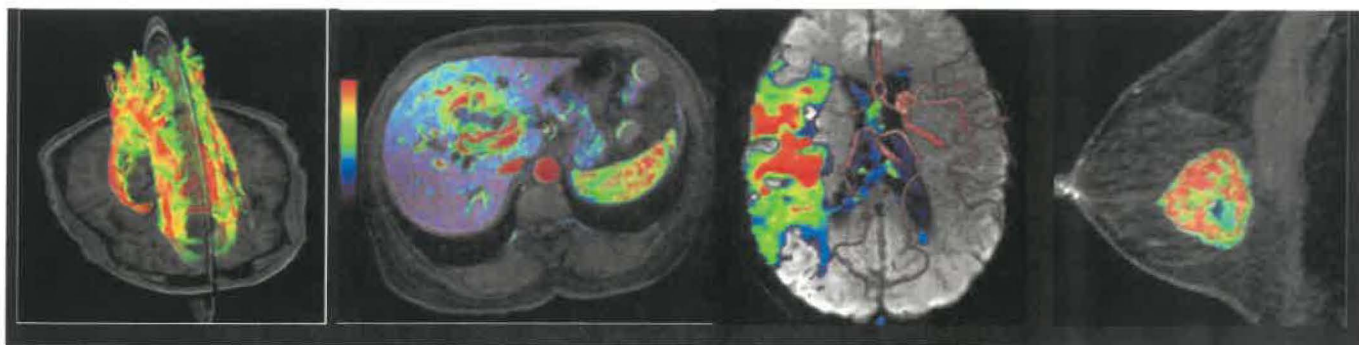

READYView (continued)

Multiparametric Protocols: Visualization at a Glance

READYView multiparametric protocols provide a guided workflow to streamline post processing and analysis of multiparametric studies. All measurements can be obtained

with one ROI and the user customizable workflow has the ability to display all processed maps in one screen.

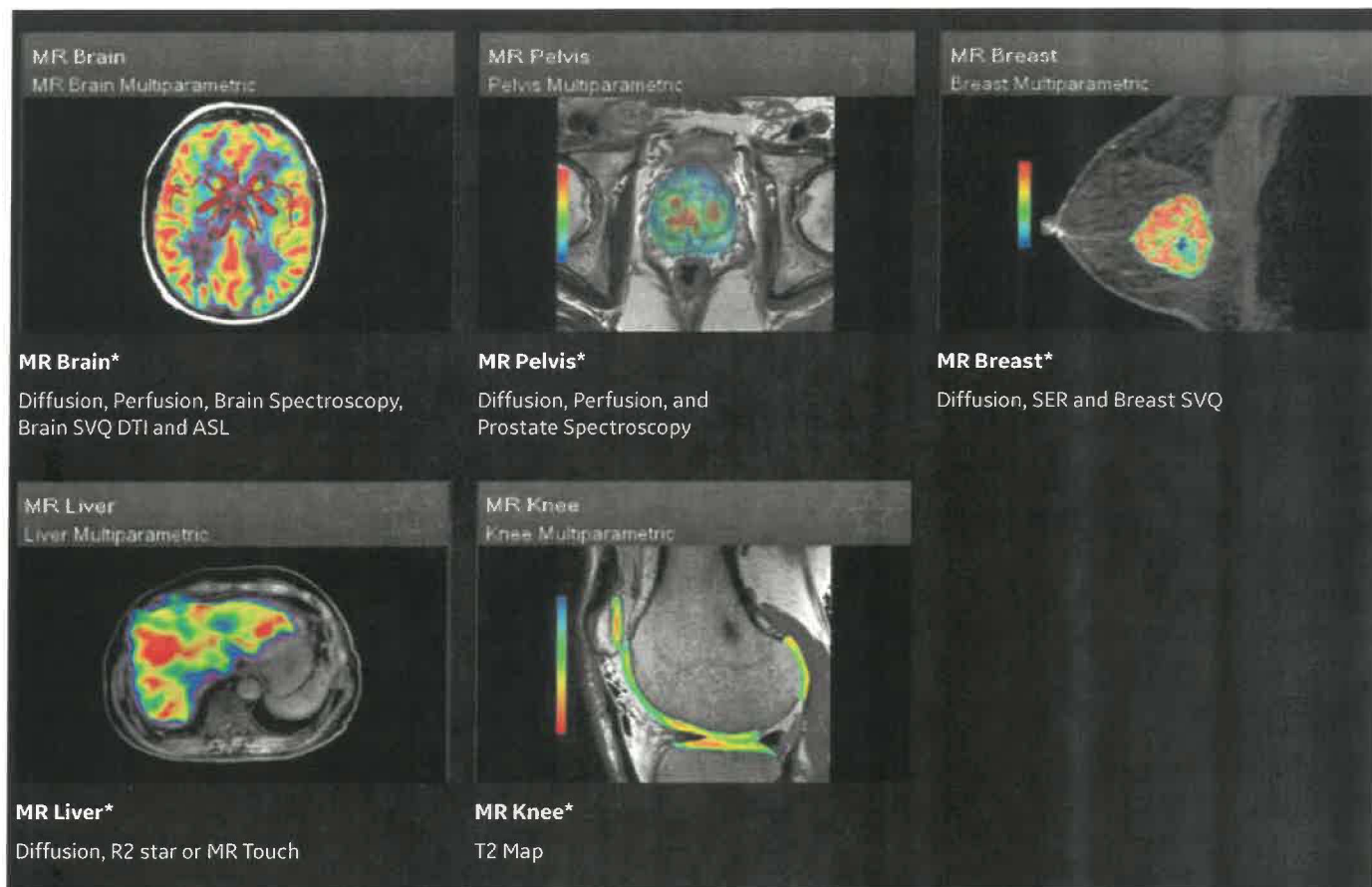

* Optional and requires two or more of the functional series selected.

Siting

Siting and Other Specifications

Typical Room Layouts

	System configuration minimum values
Magnet Room W x D	20.3 sq.m
Minimum Ceiling Height	2.5 m (8 ft. 2.4 in) min ceiling height
Equipment Room	7.9 sq.m
Control Room	3.2 sq. m

Fringe Field

	Axial	Radial
0.5 mT (5 Gauss)	4.0 m	2.5 m
0.1 mT (1 Gauss)	5.8 m	3.2 m

Electrical Supply Requirements

Supply system recommended configuration:

- 3-phase grounded WYE with neutral and ground (5-wire system)

Note: Neutral must be terminated inside main disconnect control

Alternate configuration:

- 3-phase DELTA with ground (4-wire)
- Recommended grounded delta configuration
- Voltage: 480/415/400/380/Vrms

Power Consumption / Water Requirements

Power consumption depends on actual usage. The following values are approximate:

Maximum continuous sustained power (> 5 secs)	99 kVA
Heat shield compressor	9 kVA
Maximum heat removal to customer-supplied water	49 kW
Water Flow	114 liters/min (30 gpm) min at max temperature of 10 °C

Workspace Monitor Positions

	Maximum field strength
LCD flat panel monitor	5 mT (50 Gauss)

Temperature and Humidity Requirements

	Magnet Room	Control Room	Equipment Room
Temperature	15 - 21 °C	15 - 32 °C	15 - 32 °C
Max. Temperature Change Rate	3 °C / hour	3 °C / hour	3 °C / hour
Humidity (non-condensing)	30 - 60 %	30 - 70 %	30 - 70 %
Max humidity change rate	5% RH/hr	5% RH/hr	5% RH/hr

Altitude Requirements

Upper limit	2600 m
Lower limit	-30 m

Miscellaneous

Alternative environments

Modular buildings may also be available (including air-conditioning, heating, chiller, RF shielding, additional magnetic shielding in walls). Contact your local GE representative for GE-certified designs and vendors.

Please ask your local GE project manager for a comprehensive installation and siting manual.

Filming considerations

Filming requires the SIGNA™ Artist analog or digital filming.

Interface (purchased separately) unless DICOM Print will be used exclusively for software filming to DICOM Print peripheral devices. An Analog/VDB or Digital/LCAM Camera Interface is typically required for most installations.

Accessory Package

- SPT phantom set with storage cart
- Customer diagnostic software
- Operator manuals
- Patient log books

Emergency stop

Disconnects electrical power from RF and gradient components in the magnet room (duplicate control at the magnet).

Warranty

The published GE warranty in effect on the date of shipment shall apply. GE reserves the right to make changes.

InSite* Remote Diagnostics

GE's unique remote service and applications support including magnet monitoring. Also allows downloading of applications software such as eFlexTrials program.

Accessories package

A comprehensive suite of MR compatible accessories is available on the SIGNA™ Artist. Please contact your GE representative for details.

GE regulatory compliance

The SIGNA™ Artist complies with all applicable safety standards including but not limited to IEC60601-1, IEC60601-1-2 (Electromagnetic Compatibility), and IEC 60601-2-33 (MR).





Imagination at work

© 2020 General Electric Company - All rights reserved.

GE Healthcare reserves the right to make changes in specifications and features shown herein, or discontinue the product described at any time without notice or obligation. Contact your GE Healthcare representative for the most current information. SIGNA, GE and the GE Monogram, are trademarks of General Electric Company. GE Healthcare, a division of General Electric Company. GE Medical Systems, Inc., doing business as GE Healthcare.

Reproduction in any form is forbidden without prior written permission from GE. Nothing in this material should be used to diagnose or treat any disease or condition. Readers must consult a healthcare professional.

Intel and Xeon are trademarks of Intel Corporation or its subsidiaries in the U.S. and/or other countries.

NVidia® and Quadro® are trademarks of NVIDIA Corporation.

DOC2452375

1.5T AIR™ Multi-Purpose Coils

The 21-channel AIR™ Multi-Purpose (MP) Coil Large and the 20-channel AIR™ Multi-Purpose (MP) Coil Medium are next generation multipurpose coil that allow flexibility in any direction to conform to the patient's anatomy. Based on the innovative AIR™ Coil technologies, the AIR™ MP Coils provide good image quality and acceleration performance, while improving the overall patient and user experience. These coils have been designed to adapt various patient shapes and sizes, expanding positioning versatility. AIR™ MP Coil Large is recommended to be used for Shoulder, Knee, Foot, Ankle, Hips, Prostate. AIR™ MP Coil Medium is recommended to be used for Wrist, Elbow, Cardiac.

The AIR™ MP Coil positioner kit includes a foot-ankle positioner, a knee positioner, a wedge pad, a u-shaped pad and a strap kit. Those are compatible with both AIR™ MP Coils Large and Medium for positioning.



AIR™ MP Coils Specifications

Coil	1.5T AIR™ Multi-Purpose Coil Large (1.5T AIR™ MP L)	1.5T AIR™ Multi-Purpose Coil Medium (1.5T AIR™ MP M)
Elements	21	20
Weight	1.6 kg (3.5 lbs) resting on patient 2.4kg (5.2 lbs) with the cable	1.2 kg (2.6 lbs) resting on patient 2.0kg (4.3 lbs) with the cable
Dimensions (W x L x H)	40 cm x 74 cm x 1.2 cm	40 cm x 54.5 cm x 1.2 cm
Coverage (W x L)	30 cm x 68 cm	30 cm x 48.5 cm
Patient orientation	Head first / feet first	Head first / feet first



1.5T AIR™ Multi-Purpose Coils (Continued)

Coil compatibility

SIGNA™ Artist*

Coil combinations	AIR™ MP Coil Large can be combined with the following coils:	AIR™ MP Coil Medium can be combined with the following coils:
	<ul style="list-style-type: none"> • GEM Head Neck Unit • GEM Posterior Array • 30ch AIR™ Anterior Array • TDI Anterior Array** • 2nd AIR™ MP Coil Large • AIR™ MP Coil Medium • Rapid Endorectal Coil*** 	<ul style="list-style-type: none"> • GEM Head Neck Unit • GEM Posterior Array • 30ch AIR™ Anterior Array • TDI Anterior Array** • AIR™ MP Coil Large • 2nd AIR™ MP Coil Medium • Rapid Endorectal Coil***

SIGNA™ Voyager†

Coil combinations	AIR™ MP Coil Large can be combined with the following coils:	AIR™ MP Coil Medium can be combined with the following coils:
	<ul style="list-style-type: none"> • TDI Posterior Array • TDI Anterior Array‡ • 16ch AIR™ Anterior Array‡ • Rapid Endorectal Coil 	<ul style="list-style-type: none"> • TDI Posterior Array • TDI Anterior Array‡ • 16ch AIR™ Anterior Array‡ • Rapid Endorectal Coil

*Minimum DV27.1 software

**Minimum DV29.1 software

***Minimum DV27.1 R02 software

†Minimum VX29.1 software and 49ch system configuration

‡Requires 65ch system configuration





Rutland Regional Medical Center
Rutland, Vermont
USA

REV	DATE	MODIFICATIONS
A	06/Feb/2019	Final based on request DC-85735

- C1 - 01 - Cover Sheet
- C2 - 02 - Disclaimer - Site Readiness
- A1 - 03 - General Notes
- A2 - 04 - Equipment Layout
- A3 - 05 - Section Views
- A4 - 06 - Acoustic - Proximity Limits
- A5 - 07 - RF Shielding
- A6 - 08 - Equipment Dimensions (1)
- A7 - 09 - Equipment Dimensions (2)
- A8 - 10 - Delivery
- S1 - 11 - Structural Notes
- S2 - 12 - Structural Layout

- S3 - 13 - Structural Details
- M1 - 14 - Mechanical Layout
- M2 - 15 - HVAC - Venting
- M3 - 16 - Chilled Water
- M4 - 17 - Cryogenics (1)
- M5 - 18 - Cryogenics (2)
- E1 - 19 - Electrical Notes
- E2 - 20 - Electrical Layout
- E3 - 21 - Electrical Elevation
- E4 - 22 - Electrical Details
- E5 - 23 - Power Requirements
- E6 - 24 - Interconnections



GE Healthcare

James Dombroski
 603-496-5639
 James.dombroski@med.ge.com

SIGNA ARTIST
FINAL STUDY

A mandatory component of this drawing set is the GE Healthcare Pre Installation manual. Failure to reference the Pre Installation manual will result in incomplete documentation required for site design and preparation.
 Pre Installation documents for GE Healthcare products can be accessed on the web at: www.gehealthcare.com/siteplanning

GE does not take responsibility for any damages resulting from changes on drawings made by others. Errors may occur by not referring to the complete set of final issue drawing. GE cannot accept responsibility for any damage due to the partial use of GE final issue drawings, however caused. All dimensions are in millimeters unless otherwise specified. Do not scale from printed pdf files. GE accepts no responsibility or liability for defective work due to scaling from these drawings.

Drawn by	Verified by	Concession	S.O. (GON)	PIM Manual	Rev
KRB	TNC	-	2005700941.2	5670001	11
Format	Scale	File Name		Date	Sheet
A3	1/4"=1'-0"	MRI-M133957-FIN-00-A.DWG		10/Jul/2018	01/24

DISCLAIMER

GENERAL SPECIFICATIONS

- GE is not responsible for the installation of developers and associated equipment, lighting, cassette trays and protective screens or derivatives not mentioned in the order.
- The final study contains recommendations for the location of GE equipment and associated devices, electrical wiring and room arrangements. When preparing the study, every effort has been made to consider every aspect of the actual equipment expected to be installed.
- The layout of the equipment offered by GE, the dimensions given for the premises, the details provided for the pre-installation work and electrical power supply are given according to the information noted during on-site study and the wishes expressed by the customer.
- The room dimensions used to create the equipment layout may originate from a previous layout and may not be accurate as they may not have been verified on site. GE cannot take any responsibility for errors due to lack of information.
- Dimensions apply to finished surfaces of the room.
- Actual configuration may differ from options presented in some typical views or tables.
- If this set of final drawings has been approved by the customer, any subsequent modification of the site must be subject to further investigation by GE about the feasibility of installing the equipment. Any reservations must be noted.
- The equipment layout indicates the placement and interconnection of the indicated equipment components. There may be local requirements that could impact the placement of these components. It remains the customer's responsibility to ensure that the site and final equipment placement complies with all applicable local requirements.
- All work required to install GE equipment must be carried out in compliance with the building regulations and the safety standards of legal force in the country concerned.
- These drawings are not to be used for actual construction purposes. The company cannot take responsibility for any damage resulting therefrom.

CUSTOMER RESPONSIBILITIES

- It is the responsibility of the customer to prepare the site in accordance with the specifications stated in the final study. A detailed site readiness checklist is provided by GE. It is the responsibility of the customer to ensure all requirements are fulfilled and that the site conforms to all specifications defined in the checklist and final study. The GE Project Manager of Installation (PMI) will work in cooperation with the customer to follow up and ensure that actions in the checklist are complete, and if necessary, will aid in the rescheduling of the delivery and installation date.
- Prior to installation, a structural engineer of record must ensure that the floor and ceiling is designed in such a way that the loads of the installed system can be securely borne and transferred. The layout of additional structural elements, dimensioning and the selection of appropriate installation methods are the sole responsibility of the structural engineer. Execution of load bearing structures supporting equipment on the ceiling, floor or walls are the customer's responsibility.

THE UNDERSIGNED, HEREBY CERTIFIES THAT I HAVE READ AND APPROVED THE PLANS IN THIS DOCUMENT.		
DATE	NAME	SIGNATURE

GLOBAL SITE READINESS CHECKLIST (DI)

DOC1809666 Rev. 5

Customer Name:	PMI Name:
GON/SO Number:	Field Service Name:
Equipment:	Country/City or City/State:
Required site assessment milestones	Date of completion (dd/mm/yyyy)
1) Check site before Magnet Delivery	
2) Check site before installation start	
Place an "X" in either Y or N column	
Site Ready Checks at Installation	Y N
General Site Planning	
Room dimensions, including ceiling height, for all Exam, Equipment/Technical & Control rooms meets GE specifications.	
Ceiling support structure, if indicated on the GE drawing, is in the correct location and at the correct height according to the Original Equipment Manufacturer specifications. Levelness and spacing has been measured, and is ready for the installation of any GE supplied components. Overhead support Structure has been confirmed with customer/contractor to meet required GE provided criteria.	
Rooms that will contain equipment, including staging areas if applicable, are construction debris free. Precautions must be taken to prevent debris from entering rooms containing equipment.	
Finished ceiling is installed. If applicable ceiling tiles installed per PMI discretion.	
Adequate delivery route from truck to final place of installation has been reviewed with all stakeholders, all communications/notifications have occurred, arrangements have been made for special handling (rigging, elevator, fork lift, etc.). All floors along delivery route will support weight of the equipment, temporary reinforcements arranged if needed.	
System power & grounding (PDB/MDP) is available as per GE specifications, installed at point of final connection and ready to use. Lock Out Tag Out is available.	
System power and grounded audit has been scheduled to be completed during installation of equipment. (If Required) GEHC PM to confirmed if needed.	
Adequate room illumination installed and working.	
Cable ways (floor/wall/ceiling/Access Flooring) are available for installation of GE cables and are of correct length and diameter. Cable ways routes per GE Final drawings and cable access openings areas installed at a time determined by GEHC PM. Surface floor duct can be installed at time of system installation.	
HVAC systems Installed, and the site meets minimum environmental operational system requirements.	
Network outlets installed and computer network available and working.	
Hospital IT/connectivity contacts have been engaged and information has been added to Project management tool. (If Required)	
Floor levelness/flatness is measured and within tolerance, and there are no visible defects per GEHC specifications. Floor Strength and thickness have been discussed with customer/contractor and they have confirmed GE requirements are met.	
Customer supplied countertops where GE equipment will be installed are in place.	
Specific for MR	
RF Shield installed with possible exception of magnet entrance. RF Shield Effectivity and Ground Isolation Test needed. If GE responsible for supplying RF shield, the RF shield Effectivity and Ground Isolation Test data is a Mandatory attachment into MyProjects.	
Power and connectivity is available for magnet monitoring.	
Delivery route for He dewars & gradient coil cart to the scanning room is available.	
Chilled water supply for Water Cooled Compressor or Air Cooled Compressor is ready and meets GE specifications.	
Water drain available in the equipment room, if applicable.	
Power for MR compressor & Chiller is available.	
Ensure cryogen venting system is available for magnet connection.	
Exhaust fan system is installed and operational per GE requirements.	
Status of work	
General comments	
System can be delivered	PMI signature
Site ready for installation	FS signature: optional

CUSTOMER SITE READINESS REQUIREMENTS

- Any deviation from these drawings must be communicated in writing to and reviewed by your local GE healthcare installation project manager prior to making changes.
- Make arrangements for any rigging, special handling, or facility modifications that must be made to deliver the equipment to the installation site. If desired, your local GE healthcare installation project manager can supply a reference list of rigging contractors.
- New construction requires the following;
 - Secure area for equipment,
 - Power for drills and other test equipment,
 - Capability for image analysis,
 - Restrooms.
- Provide for refuse removal and disposal (e.g. crates, cartons, packing)
- It is the customer's responsibility to contract a vibration consultant/engineer to implement site design modifications to meet the GE vibration specification. Refer to the system preinstallation manual for the vibration specification.

MRI SITE PLANNING REMINDERS

Please refer to pre-installation checklist in pre-installation manual listed on the cover sheet for items critical to image quality.

- The layout should be arranged so that the 5g line is contained to the magnet room. If not possible, a barrier is recommended to prevent entry to the 5g field area.
- The spaces around, above, and below the magnet must be reviewed for effects of the 5g, 3g, 1g, and .5g fields. Refer to the proximity limit chart in the MR pre-installation manual referenced on the cover sheet.
- For moving metal, the restriction lines typically extend outside of the MR space. Please confirm there are no moving metal concerns within these areas. An EMI study is recommended if the restriction lines are violated.
- For vibration, analysis to be completed as required per pre-installation manual.
- For EMI, review the site for the location of the main electrical feeders, AC devices, or distribution systems. An EMI study is recommended if large AC systems are nearby.
- Details of the floor below the magnet must be reviewed. The structural engineer must verify that the quantity of steel in the volume 10ft [3.1m] x 10ft [3.1m] x 1ft [.3m] deep (below the magnet) does not exceed the allowable steel content as given in the MR pre-installation manual referenced on the cover sheet.
- All access/computer flooring is to be removed in both the magnet room and equipment room.

Responsibility for the coordination, design, engineering, and site preparation resides with the customer and their project architects and contractors. GE does not, by providing reviews and furnishing comments and assistance, accept any responsibility beyond its obligations as defined in the MR system, sale/purchase agreement.

IMAGE QUALITY CONSIDERATIONS

Broadband RF noise is a single transient or continuous series of transient disturbances caused by an electrical discharge. Low humidity environmental conditions will have higher probability of electrical discharge. The electrical discharge can occur due to electrical arcing (micro arcing) or merely static discharge. Some potential sources capable of producing electrical discharge include:

- Loose hardware/fasteners vibration or movement (electrical continuity must always be maintained)
- Flooring material including raised access flooring (panels & support hardware) and carpeting
- Electrical fixtures (i.e. Lighting fixtures, track lighting, emergency lighting, battery chargers, outlets)
- Ducting for HVAC and cable routing
- RF shield seals (walls, doors, windows etc.)

For additional information regarding image quality, refer to the pre-installation manual listed on the cover sheet.

MAGNETIC INTERFERENCE SPECIFICATIONS

- The customer must establish protocols to prevent persons with cardiac pacemakers, neurostimulators, and biostimulation devices from entering magnetic fields of greater than 5 gauss (exclusion zone).
- Main power transformers must remain outside the 3 gauss field. EMI < 20mg rms ac. EMI < 5.87mg dc.
- Potential exists under fault conditions that the 5 gauss line may expand radially to 9.35 ft. [2.85 m] and axially to 14.27 ft. [4.35 m] for 1 seconds or less. It should be noted that normal rampdowns or magnet rundown unit initiated quenches will not cause the magnetic field to expand.
- It is recommended every site consider the event of a quench and plan accordingly (such as placing 5 gauss warning signs at expanded locations).
- The ferrous metal objects listed below must not move into or inside of the moving metal sensitivity line during scans.

TYPICAL MOVING MAGNETIC MASS	DISTANCE RADIALY		DISTANCE AXIALLY	
Carts, Gurneys 100-400 lbs [45-182 kg]	3 Gauss line		3 Gauss line	
Forklifts, small elevator, cars, minivans vans, pickup trucks, ambulances (objects greater than 400 lbs [182 kg])	15.5 FT	4.72 M	24.6 FT	7.5 M
Buses and trucks (dump, tractor trailer, utility, fire trucks)	18.1 FT	5.52 M	28.75 FT	8.76 M

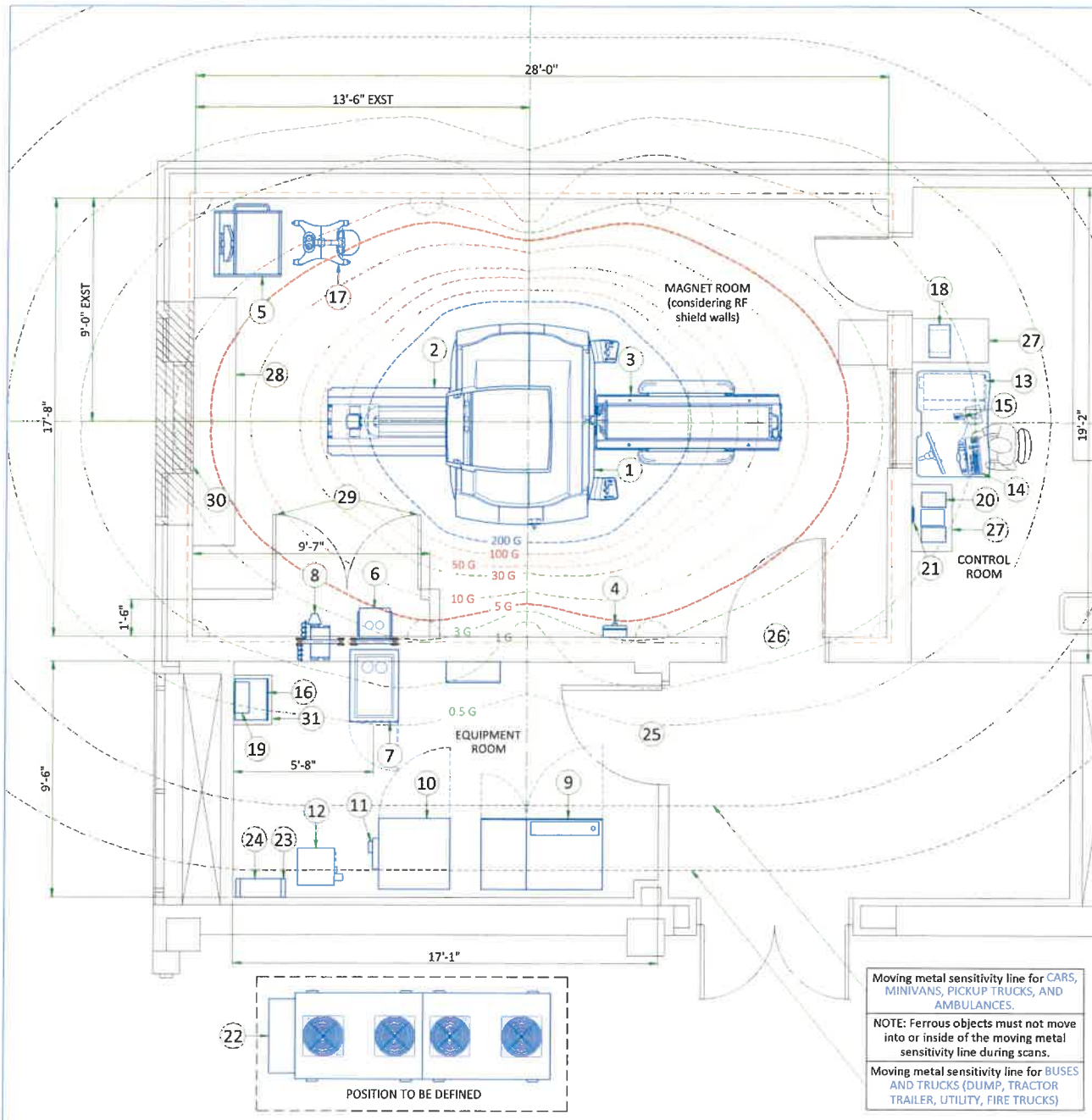

LEGEND			
A	GE Supplied	C	Customer/contractor supplied and installed
B	GE Supplied/contractor installed	D	Available from GE
--- 200 Gauss		--- 5 Gauss	
--- 100, 50, 30, 10 Gauss		--- 3, 1, 0.5 Gauss	

BY	ITEM	DESCRIPTION	MAX HEAT OUTPUT (btu)	WEIGHT (lbs)
A	1	1.5T Magnet	8189	11173
A	2	Rear pedestal	-	212
A	3	GEM Patient table	-	463
A	4	Magnet rundown unit	-	7
A	5	Phantom set storage cabinet	-	350
A	6	Blower box	1535	-
A	7	Penetration cabinet	1024 / 10697	639
A	8	Secondary penetration wall	-	92
A	9	Power, gradient, RF cabinet	20940	3144
A	10	Heat exchanger cabinet	3412	1350
A	11	Magnet monitor	819	10
A	12	Cryocooler compressor	1706	264
A	13	Operator console computer	4947	141.75
A	14	Operator workspace	-	26
A	15	Pneumatic patient alert	-	0.5
A	16	MR Elastography	480	53.4
A	17	Injector on pedestal	-	94
A	18	Injector control	675	17
A	19	Injector power supply	660	6
A	20	Music system	-	-
B	21	Remote graphic display	-	-
B	22	Dimplex chiller	167300	4000
B	23	Water filter	-	-
B	24	Water bypass	-	-
C	25	Minimum opening for equipment delivery is 40 in. w x 82 in. h, contingent on a 72 in. corridor width		
C	26	Minimum opening for equipment delivery is 43 in. w x 82 in. h, contingent on a 96 in. corridor width		
C	27	Counter top for equipment- provide grommets openings as required to route cables		
C	28	Base cabinet for storage of: surface coils, patient positioning pads, phantoms, etc.		
C	29	Louvered doors - refer to preinstall for requirements		
C	30	Magnet access 9'-0"x9'-0"		
C	31	Shelf		

EXISTING ACCESS FLOOR NOTE:
DUE TO THE WEIGHT OF THE CABINETS ALL ACCESS FLOOR NEEDS TO BE REMOVED BELOW THE CABINETS AND ALONG THE DELIVERY ROUTE.

--- RF SHIELD - 100 dB ATTENUATION

Exam room height	
Finished floor to slab height	TBD
Recommended finished ceiling height	8'-9"

Moving metal sensitivity line for CARS, MINIVANS, PICKUP TRUCKS, AND AMBULANCES.
NOTE: Ferrous objects must not move into or inside of the moving metal sensitivity line during scans.
Moving metal sensitivity line for BUSES AND TRUCKS (DUMP, TRACTOR TRAILER, UTILITY, FIRE TRUCKS)

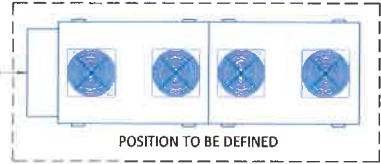

SIDE VIEW WITH MAGNETIC FIELD

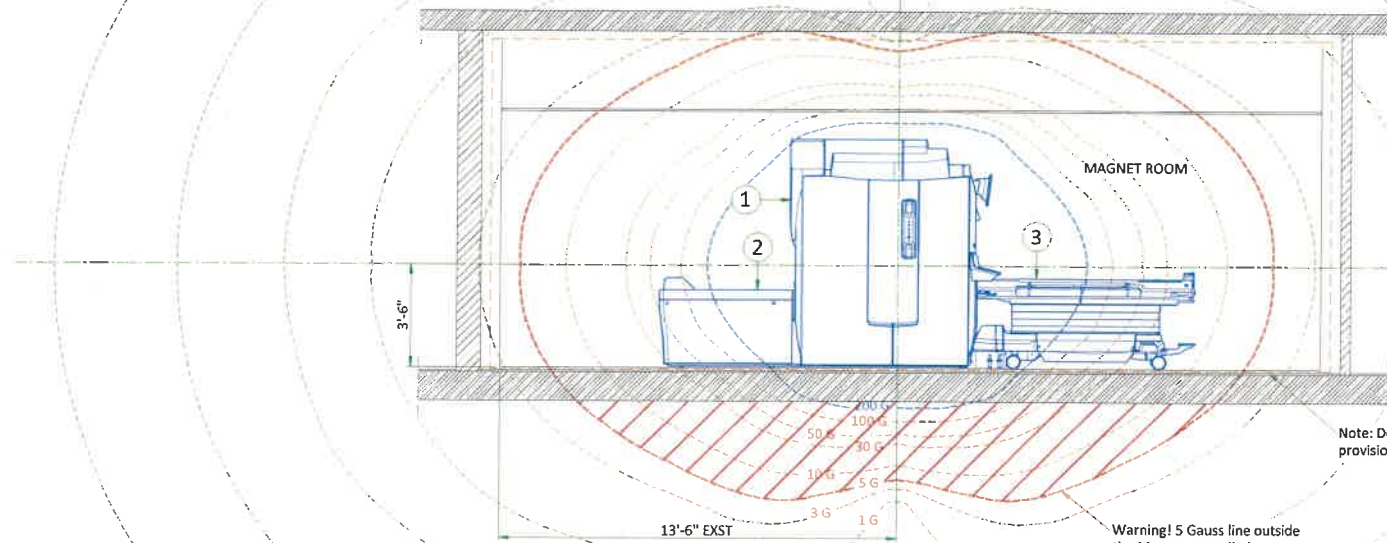

Note: Define RF shield's inset according to provisions made by the RF Shield vendor.

Warning! 5 Gauss line outside the Magnet room limits.

FRONT VIEW WITH MAGNETIC FIELD

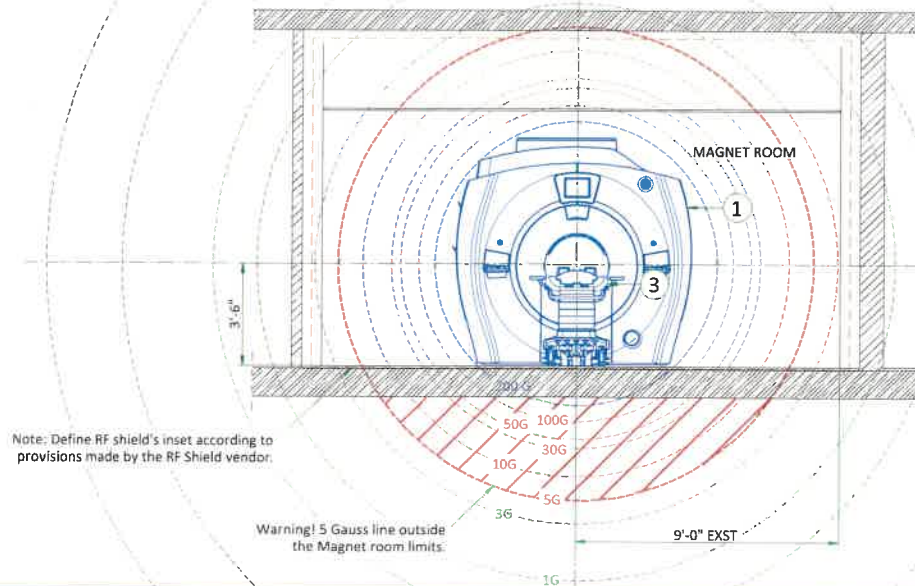

Note: Define RF shield's inset according to provisions made by the RF Shield vendor.

Warning! 5 Gauss line outside the Magnet room limits.

ACOUSTICS SPECIFICATIONS

Acoustic and vibroacoustic information is provided for site planning and architectural design activities. It is the customer's responsibility to hire a qualified acoustic engineer for solutions to further attenuate this transmitted noise and vibration, if required. The actual room noise level may vary based on room design, optional equipment, and usage:

Control Room: 62 dBA
 Equipment Room: 80 dBA
 Magnet Room: 127 dBA*
 (maximum sound pressure level at magnet bore isocenter)

* Frequency: 20 Hz to 20kHz

FREQUENCY (Hz)	AMPLITUDE (m/s ²)
2	0.05
10	0.05
20	0.35
30	0.35
35	0.2
50	0.2

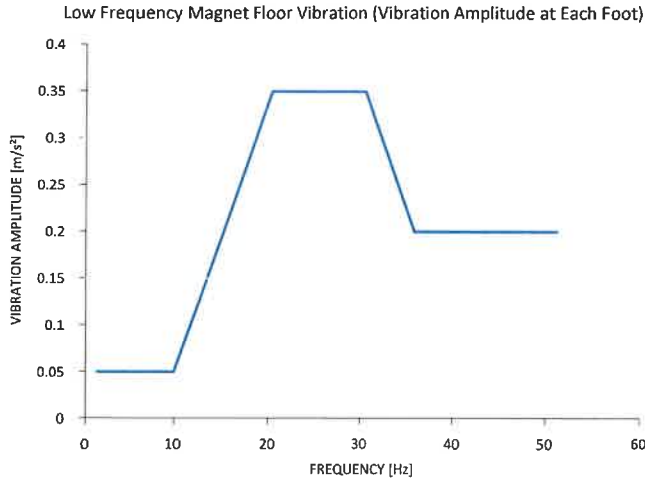

ISOGAUSS PLOTS

* The isogauss contour plots depicted on this drawing represent magnetic fringe fields resulting from the normal operation of the magnet provided with the MR system. The actual magnetic field intensity at any point in the vicinity of the magnet when installed may vary from the contour plots due to factors such as the concentrating effects of nearby ferrous objects ambient magnetic fields, including the earth's magnetic field. Therefore, the contours shown are only approximations of actual field intensities found at a corresponding distance from the magnet's isocenter.

SOUND PRESSURE SPECTRAL DISTRIBUTION

1/3 Band Relative SPL

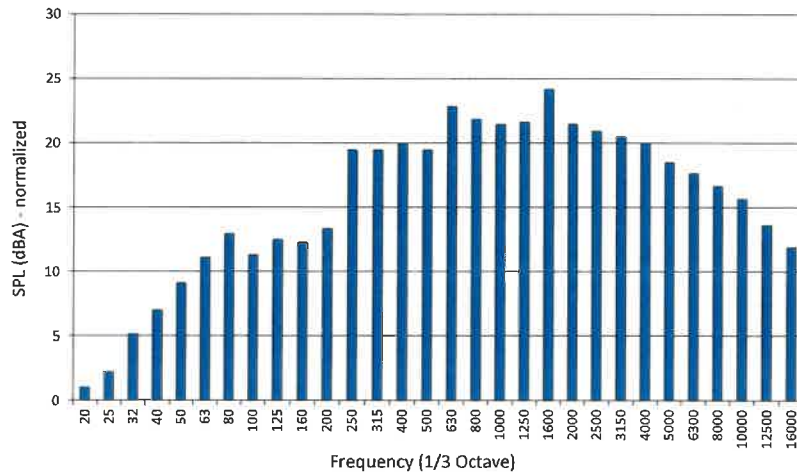

MAGNETIC PROXIMITY LIMITS

Gauss (mT) Limit	Equipment
0.5 gauss (0.05mT)	Nuclear camera
1 gauss (0.1mT)	Positron Emission Tomography scanner, Linear Accelerator, Cyclotrons, Accurate measuring scale, Image intensifiers, Bone Densitometers, Video display (tube), CT scanner, Ultrasound, Lithotripter, Electron microscope, Digital X-Ray
3 gauss (0.3mT)	Power transformers, Main electrical distribution transformers
5 gauss (0.5mT)	Cardiac pacemakers, Neurostimulators, Biostimulation devices
10 gauss (1mT)	Magnetic computer media, Line printers, Film processor, X-ray tubes, Emergency generators, Commercial laundry equipment, Food preparation area, Water cooling equipment, HVAC equipment, Major mechanical equipment room, Credit cards, watches, and clocks, Air conditioning equipment, Fuel storage tanks, Motors greater than 5 horsepower
50 gauss (5mT)	Metal detector for screening, LCD panels, Telephones
No Limit	Digital Detectors

The customer must provide detail defining ferrous material below the magnet to the Project Manager so the GE Healthcare MR Siting and Shielding team can review for compliance.

STEEL MASS LIMITS TO MAGNET ISOCENTER (3x3 m [10x10 ft] AREA UNDER MAGNET)					
Limits Of Steel Mass		Distance From Magnet Isocenter		Distance Below Top Surface Of Floor	
kg/m ²	lbs/ft ²	mm	in	mm	in
0	0	0 - 1143	0-45	0 - 76	0-3
9.8	2	1143 - 1194	45-47	76 - 127	3-5
14.7	3	1194 - 1321	47-52	127 - 254	5-10
39.2	8	1321 - 1397	52-55	254 - 330	10-13
98.0	20	1397+	55+	330+	13+

The actual field strength can be affected by Magnetic shielding, Earth's magnetic field, other magnetic fields and stationary or moving metal. This information must be used to evaluate potential site interaction of GE Healthcare equipment with other non-GE Healthcare equipment. Magnetic shielding can be installed to prevent interaction between the magnet and nearby sensitive devices. The GE Healthcare Project Manager of Installation (PMI) can work with the customer to coordinate the magnetic shielding site evaluation. The customer is responsible for installation of all magnetic shielding.

PENETRATION PANEL WITH SPW

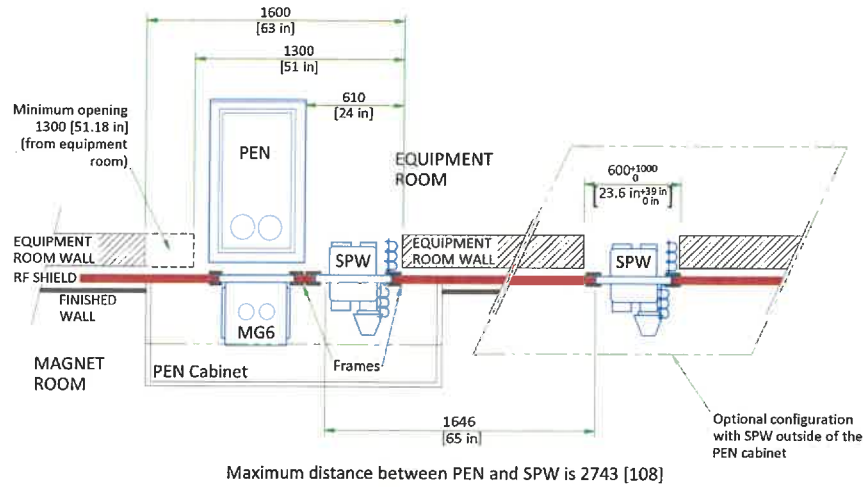

PENETRATION PANEL CLOSET

- An enclosure (i.e. closet) must be provided to restrict access to the PEN panels and for storage of excess interconnections.
- The PEN closet must have a mechanical locking mechanism to restrict access to the PEN panels
 - The PEN closet must maintain the minimum service area outside the 200 Gauss in the magnet room.
 - PEN closet must allow free air exchange of **400CFM (680 m³/hour)** between the Magnet room and PEN closet for MR system blowers. Airflow may be achieved through door louvers or other openings in the PEN closet that meet all other PEN closet requirements

A closet service hatch must be provided if the room does not allow the PEN panel blower box removal path to remain completely outside the 200 Gauss line.
 NOTE: If the room size is sufficiently large so the SPW blower box can be removed without entering the 200 Gauss line, a closet service hatch is not required.

- The closet service hatch must meet the following requirements:
- Must be located within the PEN closet on the RF wall allowing access to the Equipment room
 - May be located anywhere within the PEN closet (between 254 [10 in] and 1524 mm [60 in] with unobstructed pass-through)
 - Must be minimum 508x508 mm [20x20 in]
 - Must maintain RF shield integrity for all service access
 - May use any design (quick disconnect RF panel, blanker panel, hinged door, etc.) as long as all other requirements are met
 - The closet service hatch removal must take less than 15 minutes (replacement must also take less than 15 minutes)

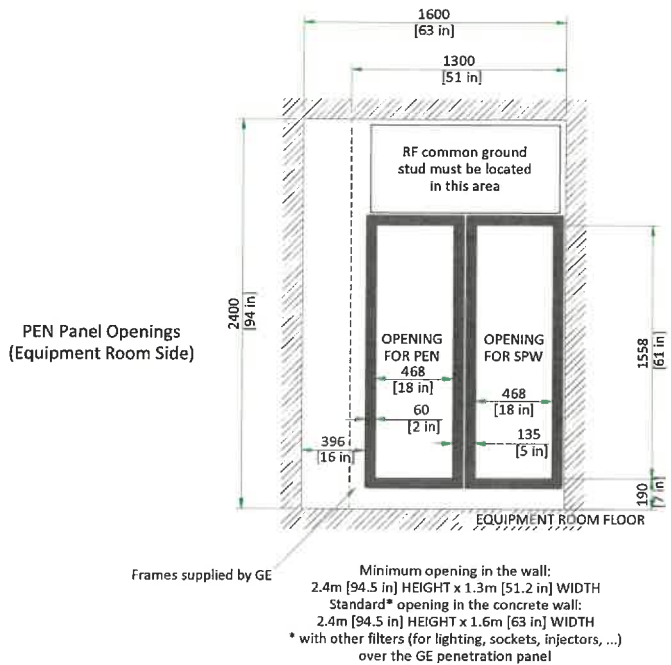

MINIMUM MAGNET CEILING HEIGHT (TOP VIEW)

Shaded area indicates floor to ceiling minimum height of 2500 mm [98.42 in]. Special service procedures are required if ceiling height is between 2500 mm [98.42 in] and 2667 mm [105 in].

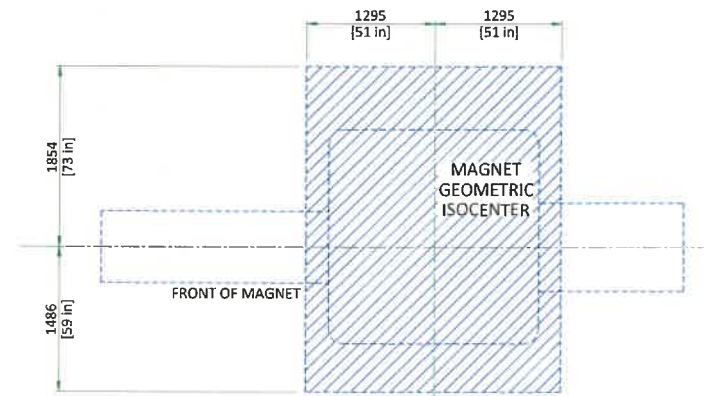

SCALE 1:30

MAGNET ENCLOSURE

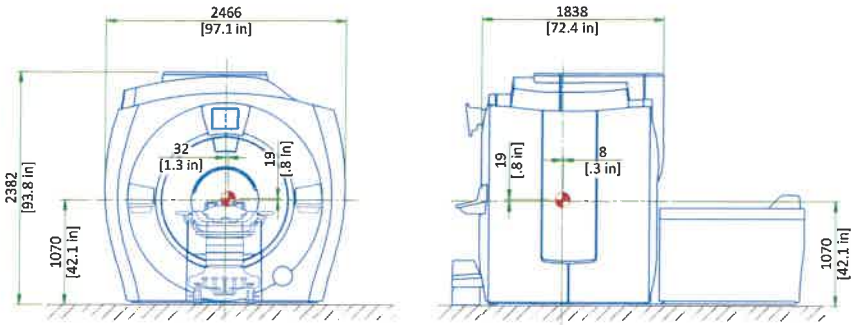

Note:
 Center of gravity is approximate and includes the GE Healthcare supplied VibroAcoustic Dampening Kit, but does not include cryogenics, gradient assembly, side mounted electronics, or enclosures.
 Enclosure dimensions are for reference only, NOT FOR SITE PLANNING USE.
 Center of gravity

PATIENT TRANSPORT TABLE (PT)

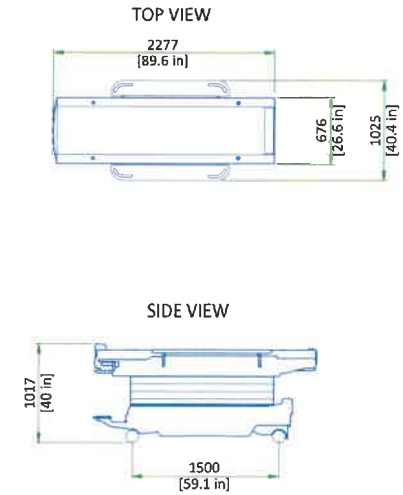

PENETRATION CABINET CLEARANCE

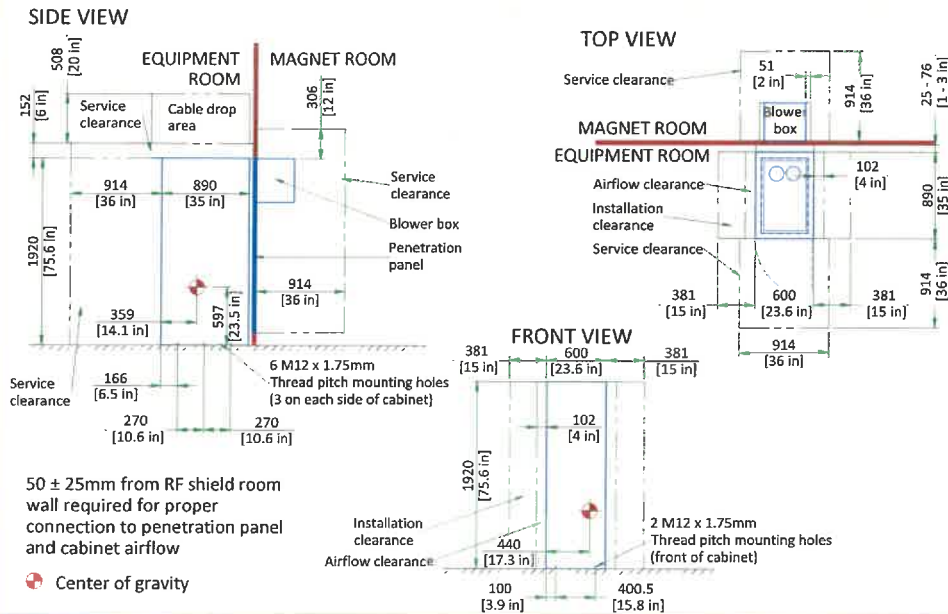

GLOBAL OPERATORS CABINET (GOC)

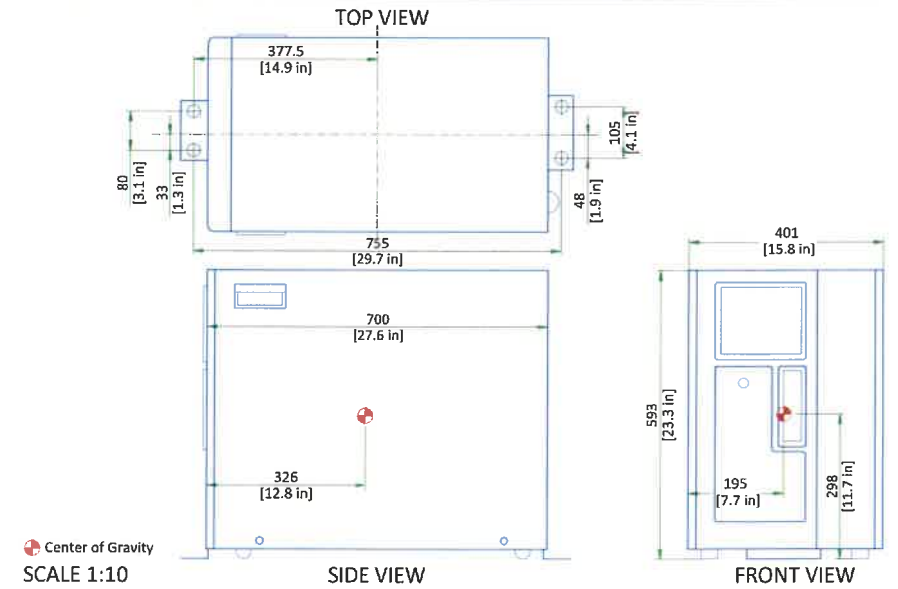

SECONDARY PENETRATION WALL (SPW)

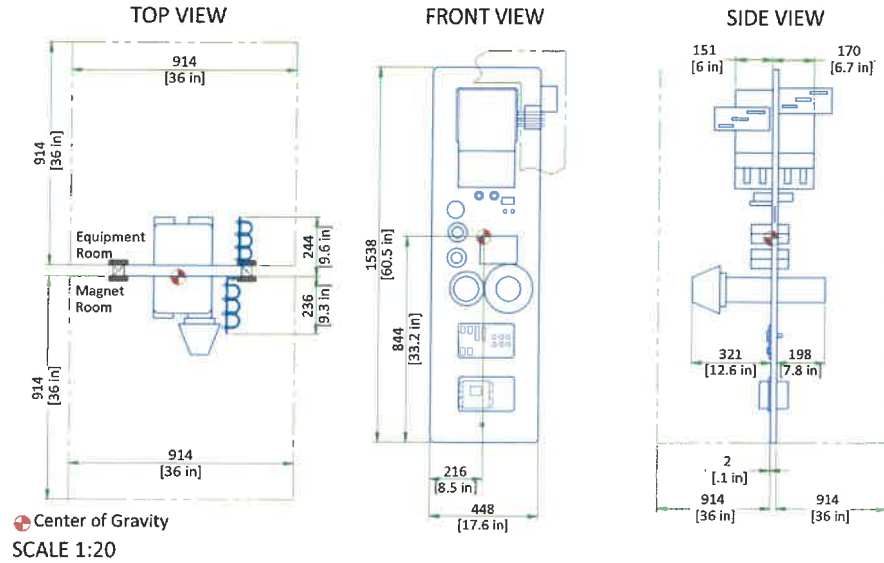

POWER, GRADIENT, RF CABINET (PGR)

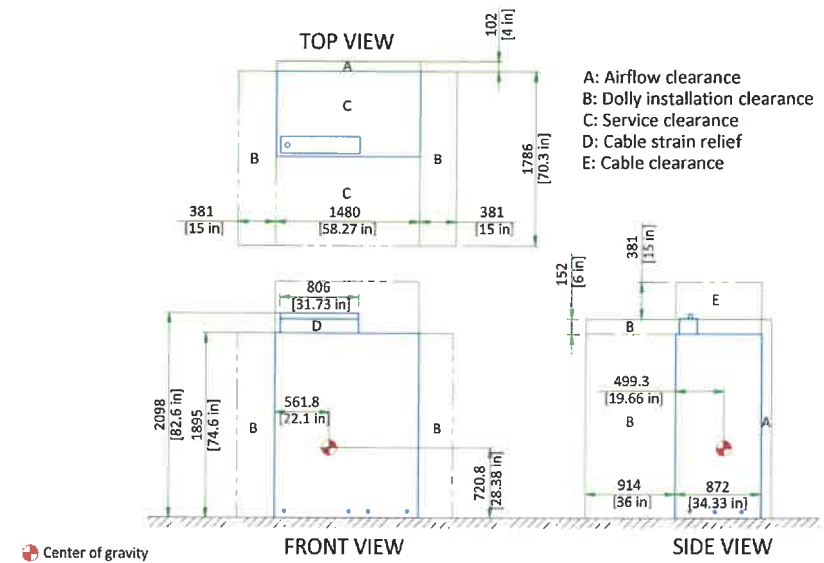

CRYOCOOLER COMPRESSOR (CRY)

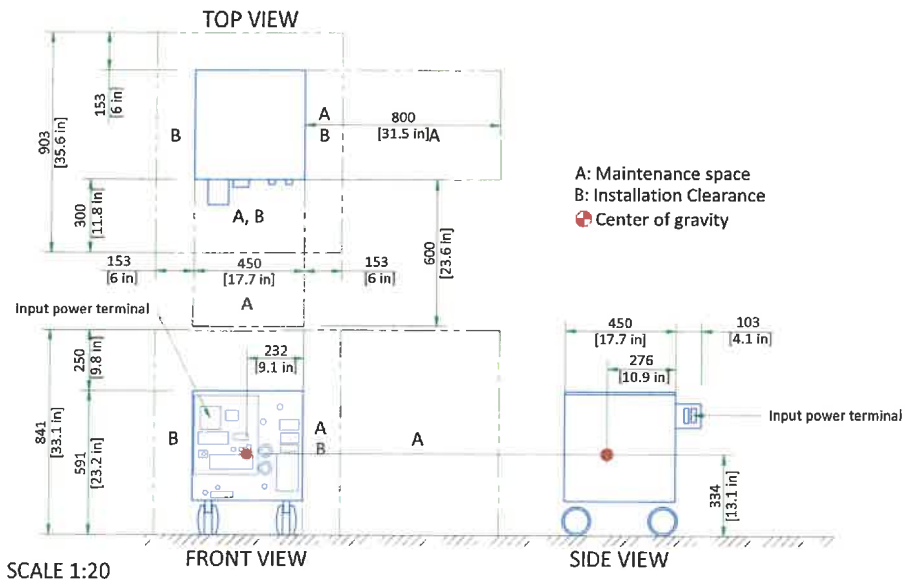

HEAT EXCHANGER CABINET (HEC)

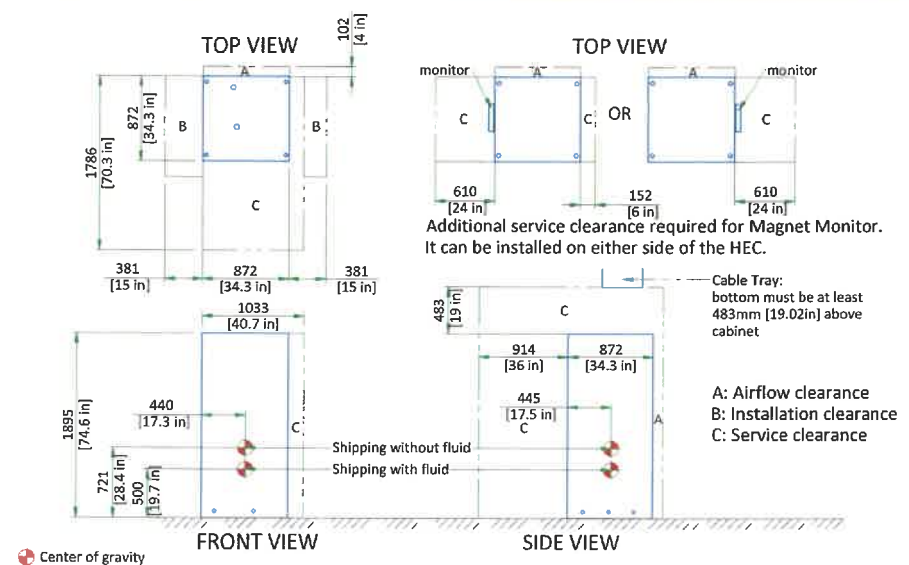

DELIVERY

ROUTING

- The customer is solely liable for routing of components from dock to final site.
- GE must be able to move system components in or out with no need to uncrate or disassemble any of the components. The entire passageway must be cleared, adequately lighted and free from dust.
- The floor and its surfacing must be able to withstand the live load of components and handling equipment.
- Floor surfacing must be continuous.
- The customer must protect any fragile flooring surfaces.

MINIMUM SPECIFICATIONS FOR MAGNET ROUTING

- Floor must be able to withstand a moving load of 5322 daN
- Height: 2.5 m [98.42in], width: 2.3 m [90.55in]
- Maximum slope: 30°

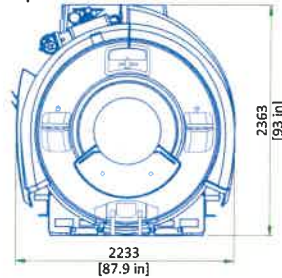

FRONT VIEW OF MAGNET

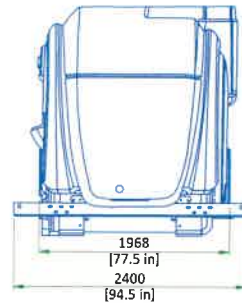

RIGHT SIDE VIEW OF MAGNET

Recommended opening for side (wall) delivery: 2300 mm [90.55in] (width) x 2500 mm [98.42in] (height)

STRAIGHT PATH
(Rigging wheels required)

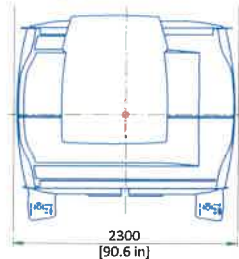

PATH WITH 90 DEGREE TURN

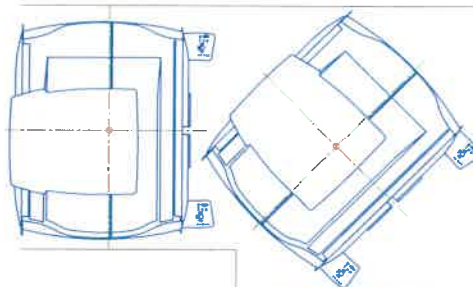

STORAGE CONDITIONS

- System components except the magnet should be stored in a cleaned room:
- Temperature = -30 to 60°C [-22 to 140], relative humidity < 90% non condensing.
- Material should not be stored for more than 90 days.
- The magnet will be delivered after GE validation of the site.

INSTALLATION AND DELIVERY ACCEPTANCE

- A survey of the site established by the customer and GE will make the decision for the delivery time.
- This survey of the site (a form is made available by GE) is only to check if the apparent conditions of the site allow the equipment to be delivered.
- If the site is not ready, GE can delay the delivery time.

CRITICAL ITEMS FOR MAGNET DELIVERY

- 24/7 chilled water and 480v power for shield/cryo cooler
- 24/7 120v power for the magnet monitor
- Phone lines for magnet monitoring and emergency use
- Magnet room exhaust fan
- Cryogen venting (if roof hatch, completed within 24 hrs)
- Magnet anchors installed and tested

This is only a partial list of items required for delivery of the magnet. For a complete checklist refer to the pre-installation manual referenced on cover sheet.

GRADIENT COIL REPLACEMENT

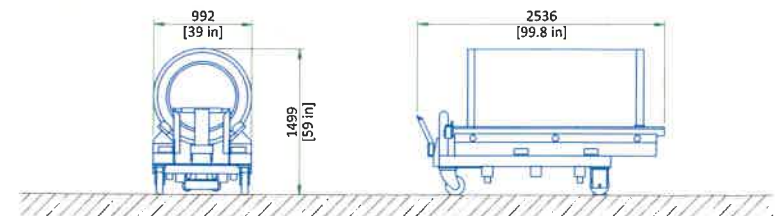

Front view of the BRM Gradient

Side view of the BRM Gradient

EQUIPMENT	DIMENSIONS LxWxH		WEIGHT		NOTE
	mm	in	kg	lbs	
Replacement BRM gradient coil assembly on a shipping cradle/cart	991x2536x1499	39x99.84x59	1449	3194	Initial gradient coil assembly is shipped installed in the magnet. Shipping/installation cart is used to install re-placement coil assembly only.

The weight bearing structure of the site should support any additional weight of the main replacement parts occurring during maintenance of the magnet, throughout the whole lifecycle of the MR.

STRUCTURAL NOTES

- All units that are wall mounted or wall supported are to be provided with supports where necessary. Wall supports are to be supplied and installed by the customer or his contractors.
- Dimensions are to finished surfaces of room.
- Certain mr procedures require an extremely stable environment to achieve high resolution image quality. Vibration is known to introduce field instabilities into the imaging system. The vibration effects on image quality can be minimized during the initial site planning of the mr suite by minimizing the vibration environment. See [PROXIMITY LIMITS, PATIENT TABLE DOCK ANCHOR MOUNTING REQUIREMENTS AND VIBROACOUSTIC DAMPENING KIT](#) details for additional information.
- Standard steel studs, nails, screws, conduit, piping, drains and other hardware are acceptable if properly secured. Any loose steel objects can be violently accelerated into the bore of the magnet. Careful thought should be given to the selection of light fixtures, cabinets, wall decorations, etc. To minimize this potential hazard. For safety, all removable items within the magnet room such as faucet handles, drain covers, switch box cover plates, light fixture components, mounting screws, etc. Must be non-magnetic. If you have a specific question about material, bring it to the attention of your GE project manager of installations.
- Floor levelness refer to [MAGNET ROOM FLOOR SPECIFICATIONS DETAIL](#), this floor levelness requirement is important for accurate patient table docking.
- Non-movable steel such as wall studs or hvac components will produce negligible effect on the active shield magnet.
- Customers contractor must provide all penetrations in post tension floors.
- Customers contractor must provide and install any non-standard anchoring. Documents for standard anchoring methods are included with GE equipment drawings for geographic areas that require such documentation.
- Customers contractor must provide and install hardware for "through the floor" anchoring and/or any bracing under access floors. This contractor must also provide floor drilling that cannot be completed because of an obstruction encountered while drilling by the GE installer such as rebar etc.
- Customers contractor to provide and install appropriate supports for the storage of excess cables.
- It is the customer's responsibility to perform any floor or wall penetrations that may be required. The customer is also responsible for ensuring that no subsurface utilities (e.g., electrical or any other form of wiring, conduits, piping, duct work or structural supports (i.e. post tension cables or rebar)) will interfere or come in contact with subsurface penetration operations (e.g. drilling and installation of anchors/screws) performed during the installation process. To ensure worker safety, GE installers will perform surface penetration operations only after the customer's validation and completion of the "GE surface penetration permit"

VIBRATION SPECIFICATIONS

Excessive vibration can affect MR image quality. Vibration testing must be performed early in the site planning process to ensure vibration is minimized. Both steady state vibration (exhaust fans, air conditioners, pumps, etc.) and transient vibrations (traffic, pedestrians, door slamming, etc.) must be assessed. The Magnet cannot be directly isolated from vibration. Any vibration issue must be resolved at the source.

Transient vibration levels above the specified limits in the MR Site Vibration Test Guidelines must be analyzed. Any transient vibration that causes vibration to exceed the steady-state level must be mitigated.

MAGNET STEADY-STATE VIBRATION SPECIFICATIONS

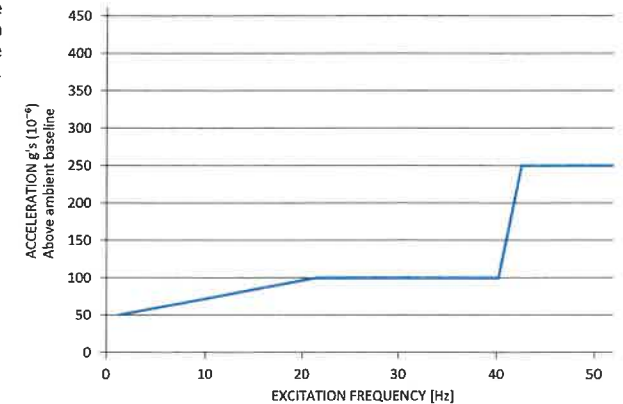

VIBRATION TRANSMITTED THROUGH VIBROACOUSTIC MAT

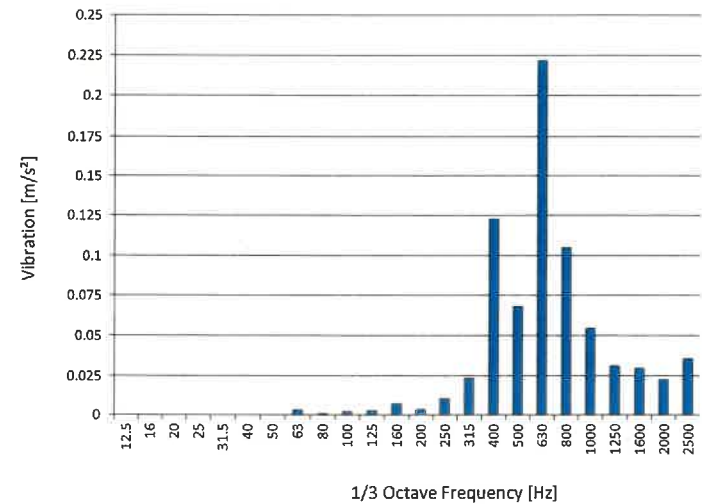

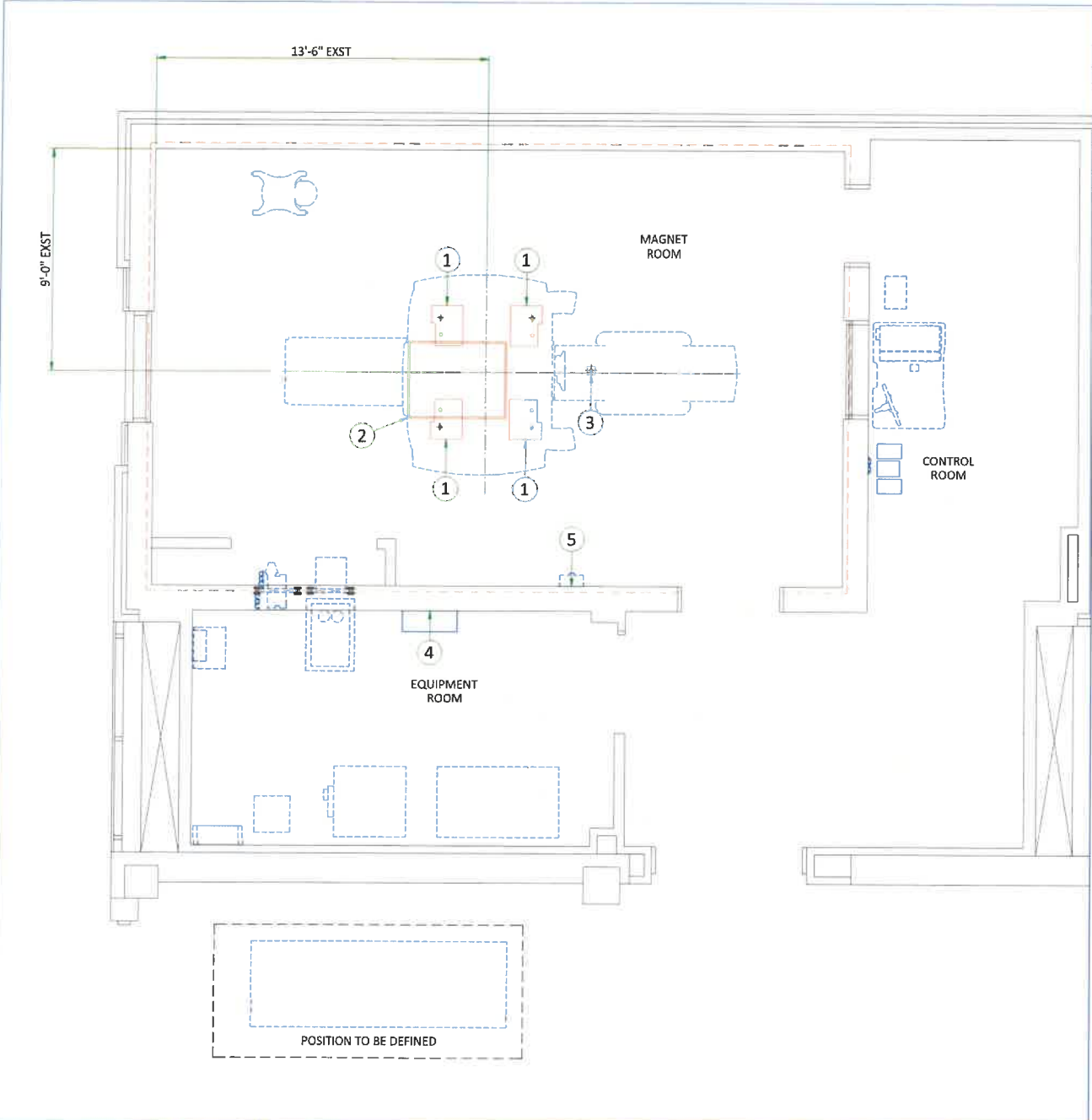

ITEM	DESCRIPTION
(GE SUPPLIED / CONTRACTOR INSTALLED)	
1	Vibroacoustic dampening kit (see floor structural detail)
2	Magnet curtain kit
(CONTRACTOR SUPPLIED & INSTALLED)	
3	Patient table dock anchoring
4	Structural wall backing for Main Disconnect Panel (Reuse existing location)
5	Structural wall backing for Magnet Rundown Unit (Reuse existing location)

MAGNET ON VIBROACOUSTIC DAMPENING KIT "VIBROPAD"

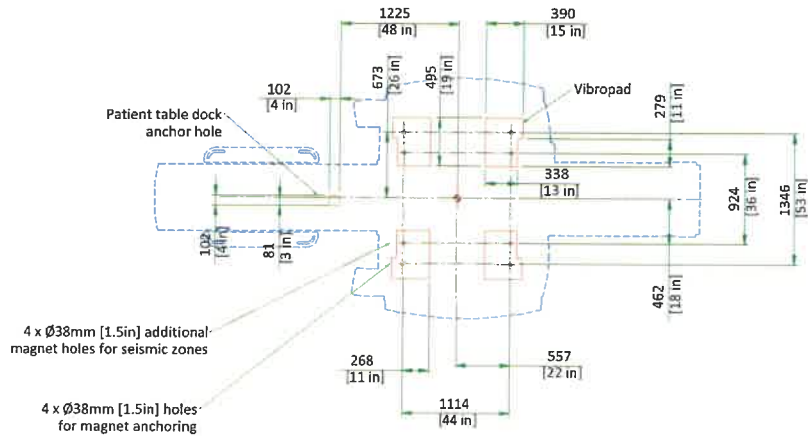

NOT TO SCALE

VibroAcoustic Pad weight:
8 kg [17 lbs] (each)

MAGNET ROOM FLOOR SPECIFICATIONS

Floor levelness must be 3 mm between high and low spots in the rectangular area shown.

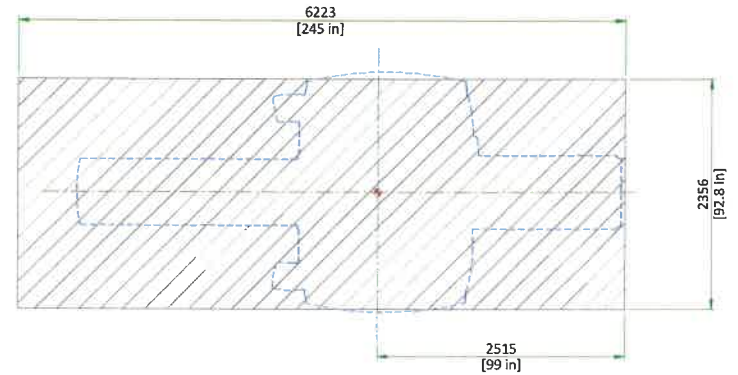

The finished floor must support the weight of all components (e.g., patient table, gradient coil replacement cart) throughout operation and service life.

PATIENT TABLE DOCK ANCHOR MOUNTING REQUIREMENTS

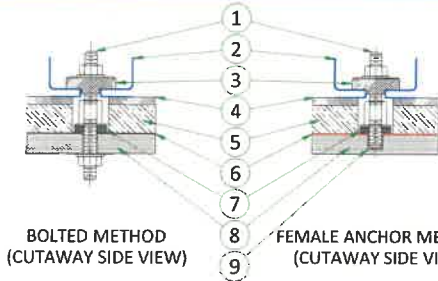

- 1 Removable Anchor Rod (Male insert)
- 2 Dock
- 3 Clamp bracket
- 4 Finished floor
- 5 Filler Board or Grout
- 6 RF Shield
- 7 Conductive Fibrous Washer (RF seal)
- 8 Concrete
- 9 Female Anchor Insert

- The RF Shield vendor must design and install the dock anchor bolt
- The dock anchor hole must be drilled **after** the Magnet is installed
- The dock anchor must not contact floor rebar or other structural steel
- The dock anchor must electrically contact the RF shield at point of entry
- The dock anchor properties must comply with requirements described in the Preinstallation Manual Chapter 3 Section 5.4.4.
- The RF shield vendor must perform a pull test on the anchor (equal to the clamping force).

NOT TO SCALE

CABLE CONCEALMENT

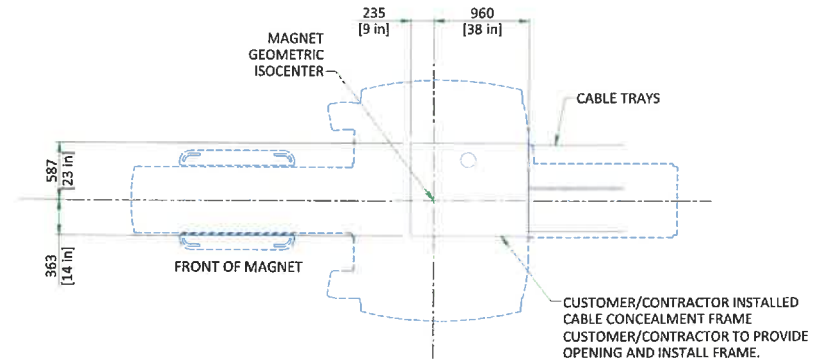

NOTE:

- THIS DRAWING IS TO BE USED ONLY AS A DESIGN INTENT DOCUMENT. REFER TO GE INSTALLATION MANUAL FOR TRAY INSTALL. ACTUAL TRAY INSTALLATION MAY BE SITE DEPENDENT.
- THIS DRAWING NOT TO SCALE

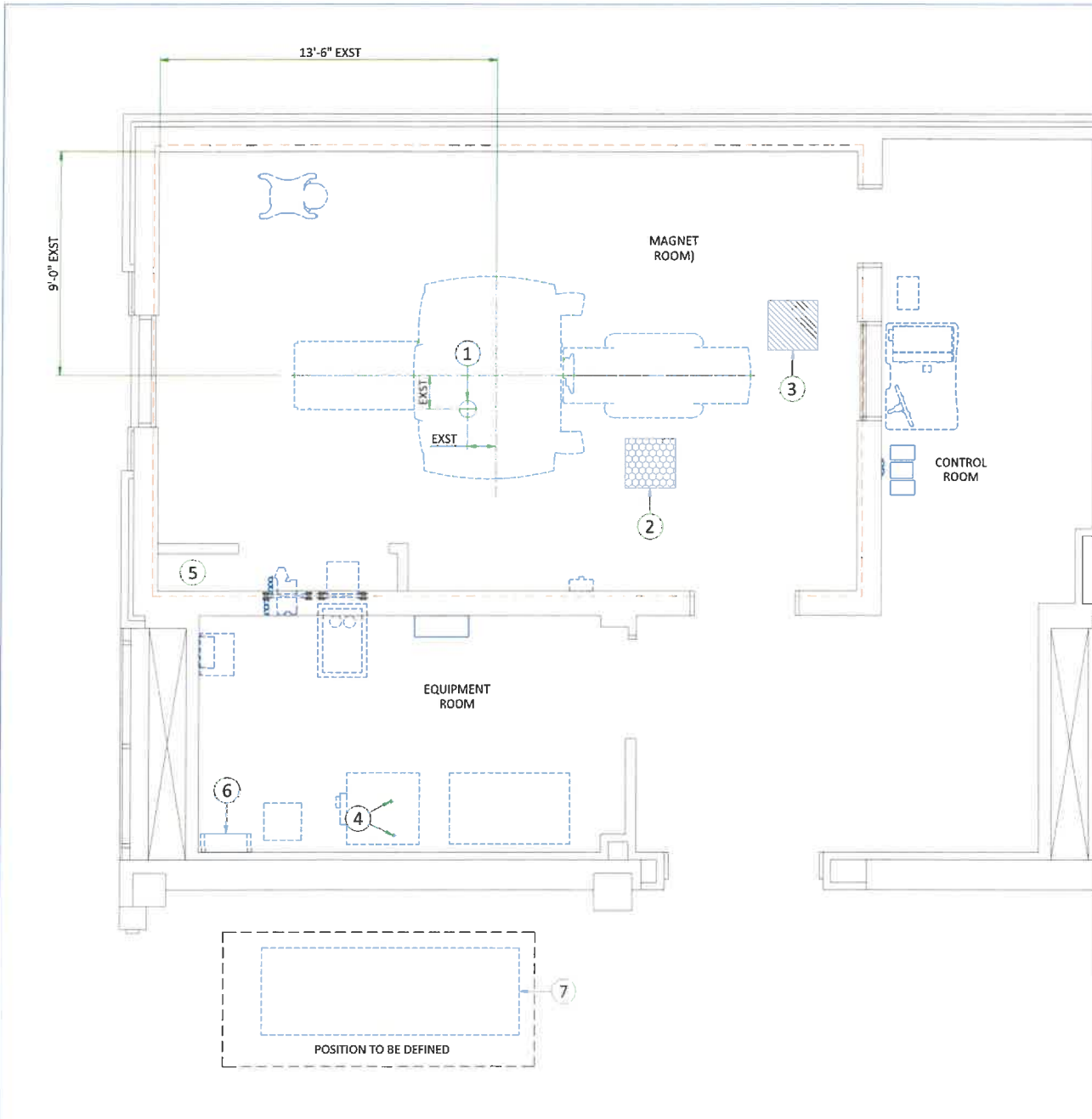

ITEM	DESCRIPTION
1	Cryogen vent (200mm [8"] O.D.) (Reuse existing location)
2	Emergency exhaust vent - refer to magnet room vent requirements (Reuse existing location)
3	Pressure equalization vent - refer to magnet room vent requirements (Reuse existing location)
4	38mm [1.5"] NPT Male connectors, at 2.1m [82.67"] above floor, (2) 38mm [1.5"] copper lines (insulated) and (2) shut off valves. refer to chilled water block diagram
5	Closet must allow free air exchange of 400 CFM between magnet room and closet
6	Provide as needed - low pressure rubber multipurpose hose, inside dia. 1/2" working pressure range: 250 to 499 PSI - refer to the manual city water back-up system detail
7	(2) 50mm [2"] I.D. High pressure hoses and (2) 50mm [2"] to 38mm [1.5"] Reducers

MECHANICAL/PLUMBING NOTES	
<ul style="list-style-type: none"> • All piping, fittings, supports, hoses, clamps, ventilation systems, etc. are to be supplied and installed by the customer or his contractors. • For complete design and requirements, specifications and guidelines refer to the pre-installation manual: system cooling, cryogen venting, waveguides and exhaust venting. • An emergency water cooling back-up supply is recommended for continuous cryogen compressor operation. if using an open loop back-up design, ensure a drain is provided. please refer to the pre-install manual for optional back-up coolant supply requirements 	

TEMPERATURE AND HUMIDITY SPECIFICATIONS

IN-USE CONDITIONS

	MAGNET ROOM			CONTROL ROOM			EQUIPMENT ROOM		
	Range			Range			Range		
Temperature	15 to 21°C			15 to 32°C			15 to 32°C		
	59 to 69.8°F			59 to 89.6°F			59 to 89.6°F		
Temperature gradient	± 3°C/h			± 3°C/h			± 3°C/h		
	± 5°F/h			± 5°F/h			± 5°F/h		
Relative humidity (1)	30% to 60%			30% to 70%			30% to 70%		
Humidity gradient	≤ 5%/h			≤ 5%/h			≤ 5%/h		
System heat dissipation	Stand by	Average	Max	Stand by	Average	Max	Stand by	Average	Max
	1.01kW	1.8kW	3.15kW		1.46kW		5.79kW	6.87kW	13.05kW
	3450 btu	6142 btu	10748 btu		4947 btu		19769 btu	23225 btu	44523 btu

NOTE
Maximum ambient temperature for the Equipment room at inlet is derated by 1°C per 300 m (984 ft) above 2000 m (6562 ft) (not to exceed 2600 m [8530 ft]).

AIR EXCHANGE

According to local standards.

NOTE
In case of using air conditioning systems or chilled water piping that have a risk of water leakage it is recommended not to install it above electric equipment or to take measures to protect the equipment from dropping water.

HEAT DISSIPATION DETAILS

DESCRIPTION	ROOM	IDLE		AVERAGE		MAX	
		W	btu	W	btu	W	btu
Magnet (MAG) and Patient Table (PT)	Magnet	561	1915	1200	4095	2400	8189
Blower Box (MG6)	Magnet	450	1535	450	1535	450	1535
Penetration Panel Cabinet (PEN)	Magnet	0	0	150	512	300	1024
Penetration Panel Cabinet (PEN)	Equipment	1568	5349	1568	5349	3135	10697
Secondary Penetration Wall (SPW)	Magnet/Equipment	0					
Main Disconnect Panel (MDP)	Equipment	132	450	132	450	264	901
Power, Gradient, RF Cabinet (PGR)	Equipment	2500	8530	3068	10470	6137	20940
Cryocooler Compressor (CRY)	Equipment	500	1706	500	1706	500	1706
Heat Exchanger Cabinet (HEC)	Equipment	500	1706	500	1706	1000	3412
Magnet Monitor (MON)	Equipment	240	819	240	819	240	819
Operator Workspace equipment (OW)	Control	1450	4947	1450	4947	1450	4947
OPTIONS							
BrainWave HW Lite Cabinet (BW)	Equipment	685	2337	685	2337	685	2337
BrainWave HW Lite Cabinet with Options	Equipment	815	2781	815	2781	815	2781
CADstream	Equipment	350	1209	799	2725	1773	6049
MR Elastography (MRE)	Equipment	141	480	141	480	141	480

MAGNET ROOM VENTING REQUIREMENTS

HVAC VENT REQUIREMENTS

- HVAC vendor must comply with Magnet room temperature and humidity specifications and RF shielding specifications.
- RF Shield vendor must install open pipe or honeycomb HVAC waveguides.
- All serviceable parts in the Magnet room (e.g.: diffusers) must be non-magnetic.
- Waveguides must be nonmagnetic and electrically isolated.
- Incoming air must contain at least 5% air from outside the Magnet room (inside or outside the facility) to displace residual helium.

EMERGENCY VENT REQUIREMENT

- Exhaust vent system is supplied by the customer.
- All items within the RF enclosure must be non-magnetic.
- The exhaust vent system must be tested and operational before the magnet is installed.
- The exhaust intake vent must be located near the magnet cryogenic vent at the highest point on the finished or drop ceiling.
- The Magnet room exhaust fan and exhaust intake vent must have a capacity of at least **1200 CFM (34 m³/min)** with a minimum of **12 room air exchanges per hour**.
 - The exhaust fan must be placed above RF shielding located outside 10 gauss (1mT) and with appropriate waveguide.
- The system must have a manual exhaust fan switch near the Operator Workspace and in the Magnet room near the door (the switches must be connected in parallel).
- All system components must be accessible for customer inspection, cleaning and maintenance

PRESSURE VENT REQUIREMENT

- A **pressure equalizing vent is required** in the magnet room ceiling or in the wall, at the highest point possible.
 - The **vent minimum size must be (610 mm x 610 mm [24 in x 24 in])** or equivalent.
 - The pressure equalization vent must be located so any Helium gas is not vented into occupied areas.
- Note: Location may affect acoustic noise transmission into occupied spaces.

MAGNET ROOM EXHAUST FAN SCHEMATIC

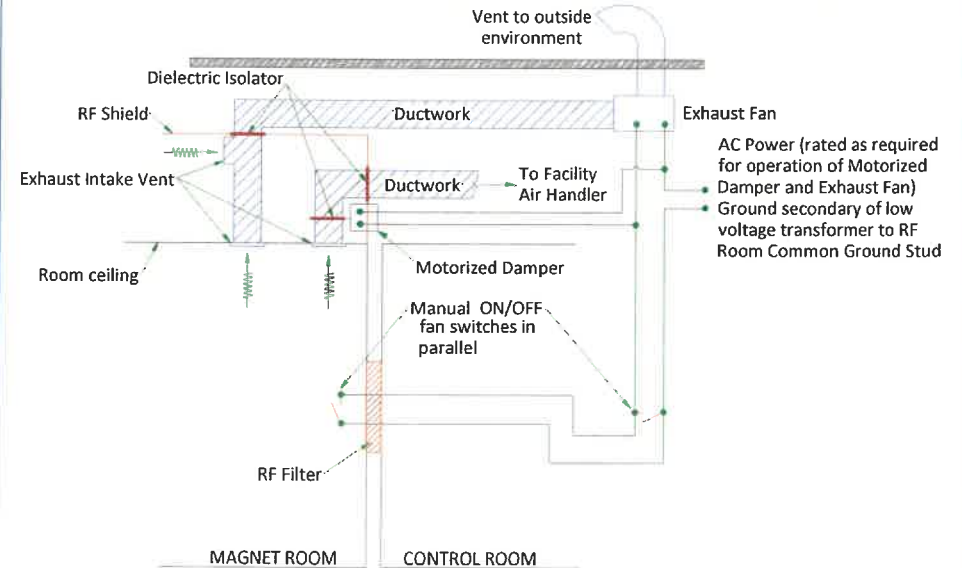

CHILLED WATER BLOCK DIAGRAM

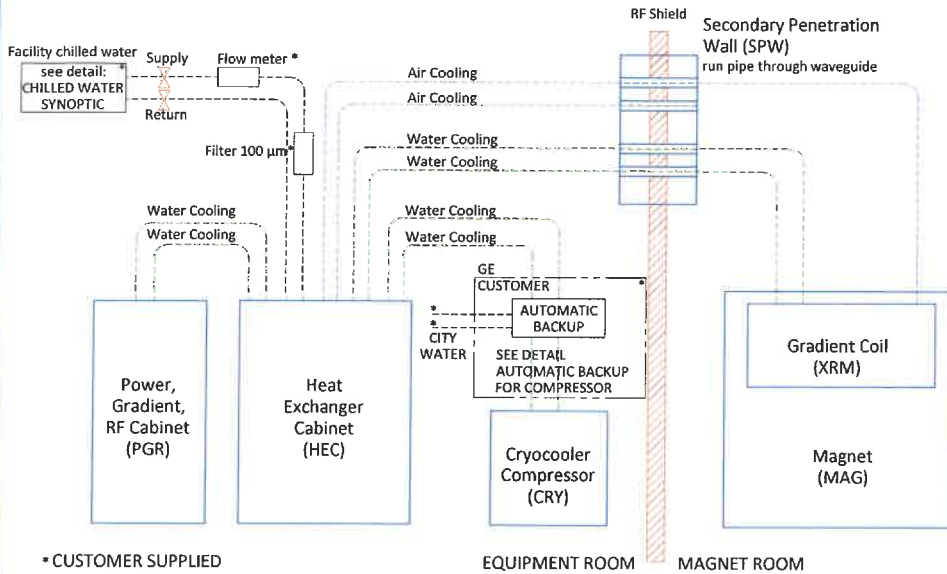

CHILLED WATER SPECIFICATIONS

PARAMETER		REQUIREMENTS	
Chiller size		Minimum 49 kW	
Inlet temperature		6 to 12°C [42.8 to 53.6°F] measured at the inlet to the HEC	
Hose connections to the HEC (supplied by customer)		1.5 inch [38.1 mm] male NPT	
		MINIMUM FLOW 114 l/min [30 gpm]	MAXIMUM FLOW 132 l/min [35 gpm]
PRESSURE DROP IN HEC CABINET	40% propylene glycol	2.4 bars [34.8 psi]	3.3 bars [47.8 psi]
Availability		Continuous	
Antifreeze		no more than 40% propylene glycol	
Temperature rise at minimum flow		6.8°C [12.2°F] with 40% propylene glycol-water 3730J/(kgK) specific heat, 1021kg/m³ density, 49kW heat	
Temperature rise at maximum flow		5.8°C [10.4°F] with 40% propylene glycol-water 3730J/(kgK) specific heat, 1021kg/m³ density, 49kW heat	
Maximum inlet pressure to HEC		6 bar [87 psi]	
Minimum continuous heat load		7.5 kW	
Hoses to be provided by customer		38.1 mm [1.5 in] minimum hose inside diameter	
pH level		6.5 to 8.2 at 25°C [77°F]	
Total hardness		Less than 200 ppm	
Suspended matter		Less than 10 ppm	
Particle size		Less than 100 micron	
Facility filter		100 micron or smaller with a field-changeable filter	
Condensation protection		Facility plumbing to the HEC must be properly routed and insulated to prevent equipment damage or safety hazards	

CITY WATER BACKUP SPECIFICATIONS FOR COMPRESSOR

INLET WATER FLOW/TEMPERATURE FOR CRYOCOOLER COMPRESSOR

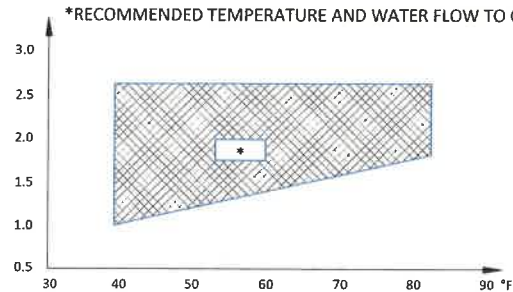

	MIN	MAX
INLET TEMP	39.2°F (4°C)	82.4°F (28°C)
INLET FLOW	1.0 gpm (4 l/min)	2.6 gpm (10 l/min)
TEMP RISE	89.6°F at 1.0 gpm (32°C at 4 l/min flow)	53.6°F at 2.6 gpm (12°C at 10 l/min flow)
HEAT DISSIPATION (kW)	7.2 kW	
PRESSURE DROP	8.7 psi at 2.1 gpm flow (60 kPa at 8 l/min flow)	

MANUAL CITY WATER BACKUP SYSTEM (SAMPLE-DIMPLEX)

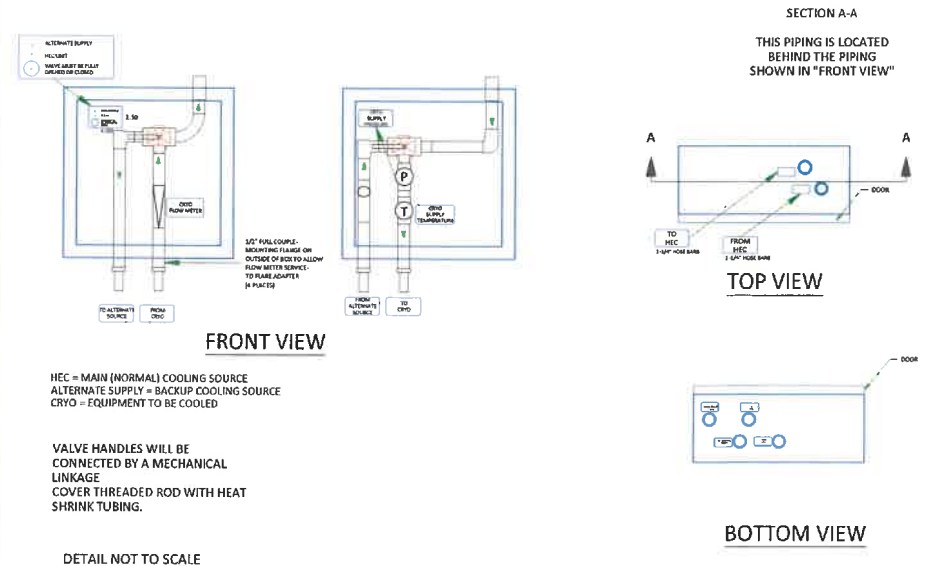

TYPICAL CRYOGENIC VENT PIPE DETAIL

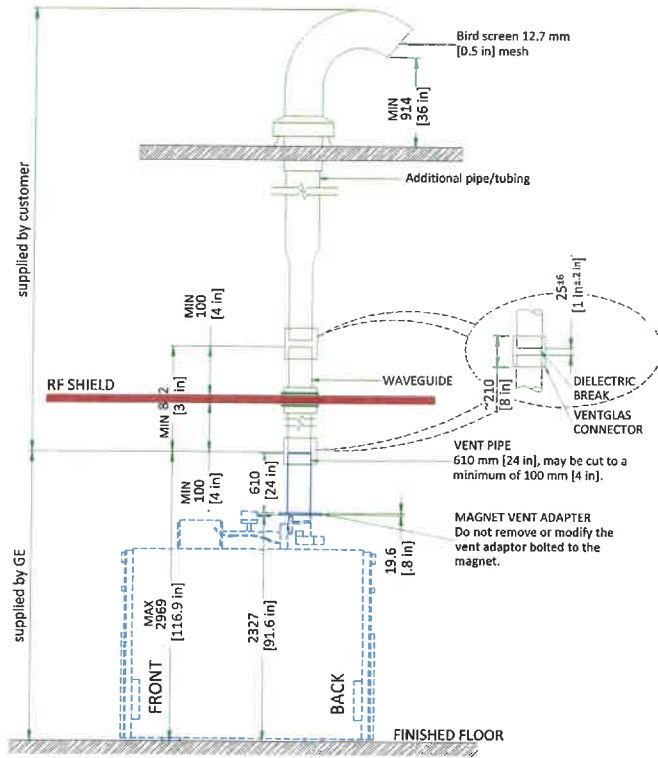

Waveguide is contractor supplied. Minimum 812 mm [32 in]. Must extend at least 100 mm [4 in] on magnet room side of the wall/ceiling and 25±6 mm [1±0.25 in] from the GE supplied pipe below isolation joint. Magnet room end must not be more than 2969 mm [117 in] above finished floor.

1. The 203 mm [8 in] OD vent material must be one of the following materials with the wall thickness indicated:
 - a. SS 304: Minimum 0.89 mm [0.035 in]; Maximum 3.18 mm [0.125 in]
 - b. AL 6061-T6: Minimum 2.11 mm [0.083 in]; Maximum 3.18 mm [0.125 in]
 - c. CU DWV, M or L: Minimum 2.11 mm [0.083 in]; Maximum 3.56 mm [0.140 in]
2. Either tubes or pipes may be used and must be seamless or have welded seams

NOTE

All welds on the pipe must be ground down to a smooth 203 mm [8 in] diameter so that it can be clamped to the Ventglas with enough force.

3. Corrugated pipe or spiral duct must not be used
4. If required, bellows pipe less than 300 mm [12 in] in length may be used as a thermal expansion joint
5. The vent pipe must withstand the maximum pressure listed in the Pre-Installation Manual
6. Waveguide vent material must match the outside diameter of the magnet flanged vent adapter

TYPICAL CRYOGEN SIDE WALL EXIT WITH LONG SWEEP ELBOW

KEY COMPONENTS :

- RF waveguide extended from wall to magnet adapter
- Must be all same material and all welded
- Support system must withstand 8229 N [1850 lbs]
- GE ventglas must be installed in vertical section directly over magnet

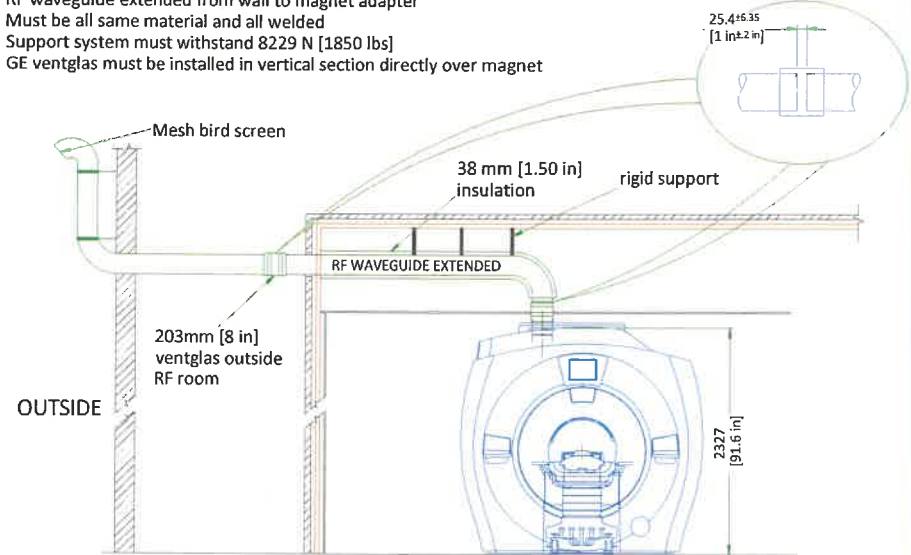

CRYOGENIC VENTING (EXTERIOR)

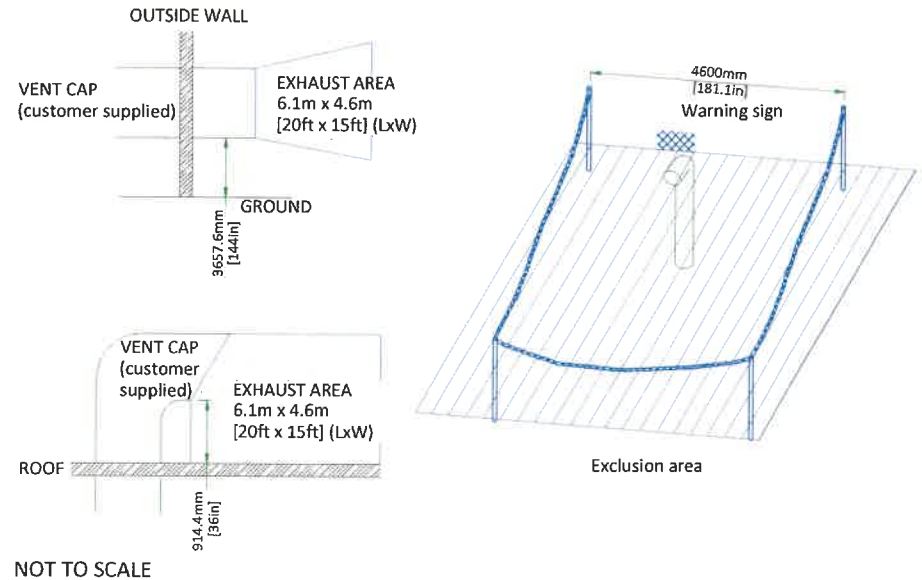

NOT TO SCALE

MAGNET CRYOGENIC VENT SYSTEM PRESSURE DROP MATRIX

Outer dia. of pipe (D)	Distance of vent system component from magnet		Pressure drop for straight pipe		Std sweep 45° elbow		Std sweep 90° elbow		Long sweep 45° elbow		Long sweep 90° elbow	
	ft	m	psi/ft	kPa/m	psi	kPa	psi	kPa	psi	kPa	psi	kPa
8 in. (200mm)	0-20	0-6.1	0.10	2.26	1.10	7.58	2.06	14.20	0.55	3.79	1.03	7.10
	20-40	6.1-12.2	0.21	4.75	2.10	14.48	3.70	25.51	1.03	7.10	1.85	12.76
	40-60	12.2-18.3	0.30	6.79	2.88	19.86	5.21	35.92	1.44	9.93	2.60	17.92
	60-80	18.3-24.4	0.38	8.60	3.70	25.51	6.71	46.27	1.85	12.76	3.36	23.17
	80-100	24.4-30.5	0.47	10.63	4.52	31.17	8.22	56.68	2.26	15.58	4.11	28.34
10 in. (250mm)	0-20	0-6.1	0.03	0.68	0.55	3.79	0.82	5.65	0.27	1.86	0.04	2.83
	20-40	6.1-12.2	0.07	1.58	0.82	5.65	1.51	10.41	0.41	2.83	0.75	5.17
	40-60	12.2-18.3	0.10	2.26	1.23	8.48	2.19	15.10	0.62	4.27	1.10	7.58
	60-80	18.3-24.4	0.12	2.71	1.51	10.41	2.74	18.89	0.75	5.17	1.37	9.45
	80-100	24.4-30.5	0.16	3.62	1.92	13.24	3.43	23.65	0.96	6.62	1.71	11.79
12 in. (300mm)	0-20	0-6.1	0.013	0.29	0.27	1.86	0.41	2.83	0.14	0.97	0.21	1.45
	20-40	6.1-12.2	0.027	0.61	0.41	2.83	0.82	5.65	0.21	1.45	0.41	2.83
	40-60	12.2-18.3	0.041	0.93	0.55	3.79	1.10	7.58	0.27	1.86	0.55	3.79
	60-80	18.3-24.4	0.054	1.22	0.69	4.76	1.37	9.45	0.34	2.34	0.69	4.76
	80-100	24.4-30.5	0.069	1.56	0.96	6.62	1.51	10.41	0.48	3.31	0.75	5.17
14 in. (350mm)	0-20	0-6.1	0.008	0.055	0.20	1.3800	0.301	2.08	0.102	0.70	0.15	1.03
	20-40	6.1-12.2	0.017	0.12	0.30	2.07	0.602	4.15	0.154	1.06	0.30	2.07
	40-60	12.2-18.3	0.026	0.18	0.40	2.76	0.808	5.57	0.198	1.37	0.40	2.76
	60-80	18.3-24.4	0.034	0.23	0.51	3.52	1.01	6.96	0.250	1.72	0.51	3.52
	80-100	24.4-30.5	0.043	0.30	0.71	4.90	1.11	7.65	0.353	2.43	0.55	3.79
16 in. (400mm)	0-20	0-6.1	0.0053	0.037	0.153	1.05	0.230	1.59	0.078	0.54	0.115	0.79
	20-40	6.1-12.2	0.013	0.09	0.229	1.58	0.460	3.17	0.188	0.81	0.229	1.58
	40-60	12.2-18.3	0.020	0.14	0.306	2.11	0.618	4.26	0.152	1.05	0.306	2.11
	60-80	18.3-24.4	0.026	0.18	0.390	2.69	0.773	5.33	0.191	1.32	0.390	2.69
	80-100	24.4-30.5	0.033	0.23	0.543	3.74	0.850	5.86	0.270	1.86	0.421	2.90

Notes

1. Elbows with angles greater than 90 deg must not be used
2. Data in Table is based on the following facts and assumptions:
 - a. Initial flow conditions at magnet interface
 - b. EM energy (13MJ) is dumped to He during quench and rises He temperature to 10 Kelvin
 - c. Gas temperature starting at 10 Kelvin and increase with length determined by thermal energy balance
 - d. 90% He is assumed to be evacuated within 30 sec. None left after quench.
 - e. Absolute roughness is assumed to be 0.25 mm.
 - f. R/D = 1.0 for standard sweep elbows, R/D = 1.5 for long sweep elbows where D = outer diameter of pipe; R = radius of bend
3. The total pressure drop of the entire cryogenic vent system must be less than 17 psi (117.2 kPa). The calculation starts at the magnet vent interface and ends at the termination point outside the building.

LIGHTING REQUIREMENTS

- All lighting fixtures and associated components must meet all RF shielded room and RF grounding requirements (e.g., track lighting is not recommended due to possible RF noise).
- All lighting must use direct current (the DC must have less than 5% ripple).
- 300 lux must be provided at the front of the magnet for patient access and above the magnet for servicing.
- Fluorescent lighting must not be used in the magnet room.
- Lighting must be adjusted using a discrete switch or a variable DC lighting controller.
- Scr dimmers or rheostats must not be used.
- DC led lighting may be used if the power source is located outside the magnet room RF.
- Battery chargers (e.g., used for emergency lighting) must be located outside the magnet RF room.
- Short filament length bulbs are recommended.
- Linear lamps are not recommended due to the high burnout rate.

CONNECTIVITY REQUIREMENTS

Broadband Connections are necessary during the installation process and going forward to ensure full support from the Engineering Teams for the customers system. Maximum performance and availability for the customers system is maintained and closely monitored during the lifetime of the system. Proactive and reactive maintenance is available utilizing the wide range of digital tools using the connectivity solutions listed below:

- Site-to-Site VPN/GE Solution
- Site-to-Site VPN/Customer Solution
- Connection through Dedicated Service Network
- Internet Access - connectivity for InSite 2.0

The requirements for these connectivity solutions are explained in the broadband solutions catalogue (separate document).

ELECTRICAL NOTES

1. All wires specified shall be copper stranded, flexible, thermo-plastic, color coded, cut 10 foot long at outlet boxes, duct termination points or stubbed conduit ends. All conductors, power, signal and ground, must be run in a conduit or duct system. Electrical contractor shall ring out and tag all wires at both ends. Wire runs must be continuous copper stranded and free from splices.
 - 1.1. Aluminum or solid wires are not allowed.
2. Wire sizes given are for use of equipment. Larger sizes may be required by local codes.
3. It is recommended that all wires be color coded, as required in accordance with national and local electrical codes.
4. Conduit sizes shall be verified by the architect, electrical engineer or contractor, in accordance with local or national codes.
5. Convenience outlets are not illustrated. Their number and location are to be specified by others. Locate at least one convenience outlet close to the system control, the power distribution unit and one on each wall of the procedure room. Use hospital approved outlet or equivalent.
6. General room illumination is not illustrated. Caution should be taken to avoid excessive heat from overhead spotlights. Damage can occur to ceiling mounting components and wiring if high wattage bulbs are used. Recommend low wattage bulbs no higher than 75 watts and use dimmer controls (except mr). Do not mount lights directly above areas where ceiling mounted accessories will be parked.
7. Routing of cable ductwork, conduits, etc., must run direct as possible otherwise may result in the need for greater than standard cable lengths (refer to the interconnection diagram for maximum usable lengths point to point).
8. Conduit turns to have large, sweeping bends with minimum radius in accordance with national and local electrical codes.
9. A special grounding system is required in all procedure rooms by some national and local codes. It is recommended in areas where patients might be examined or treated under present, future, or emergency conditions. Consult the governing electrical code and confer with appropriate customer administrative personnel to determine the areas requiring this type of grounding system.
10. The maximum point to point distances illustrated on this drawing must not be exceeded.
11. Physical connection of primary power to GE equipment is to be made by customers electrical contractor with the supervision of a GE representative. The GE representative would be required to identify the physical connection location, and insure proper handling of GE equipment.
12. GEHC conducts power audits to verify quality of power being delivered to the system. The customer's electrical contractor is required to be available to support this activity.

- All junction boxes, conduit, duct, duct dividers, switches, circuit breakers, cable tray, etc., are to be supplied and installed by customers electrical contractor.
- Conduit and duct runs shall have sweep radius bends
- Conduits and duct above ceiling or below finished floor must be installed as near to ceiling or floor as possible to reduce run length.
- Ceiling mounted junction boxes illustrated on this plan must be installed flush with finished ceiling.
- All ductwork must meet the following requirements:
 1. Ductwork shall be metal with dividers and have removable, accessible covers.
 2. Ductwork shall be certified/rated for electrical power purposes.
 3. Ductwork shall be electrically and mechanically bonded together in an approved manner.
 4. PVC as a substitute must be used in accordance with all local and national codes.
- All openings in access flooring are to be cut out and finished off with grommet material by the customers contractor.
- General contractor to insert pull cords for all cable run conduits between the equipment room and the operators control room.
- 10 foot pigtails at all junction points.
- Grounding is critical to equipment function and patient safety. Site must conform to wiring specifications shown on this plan.

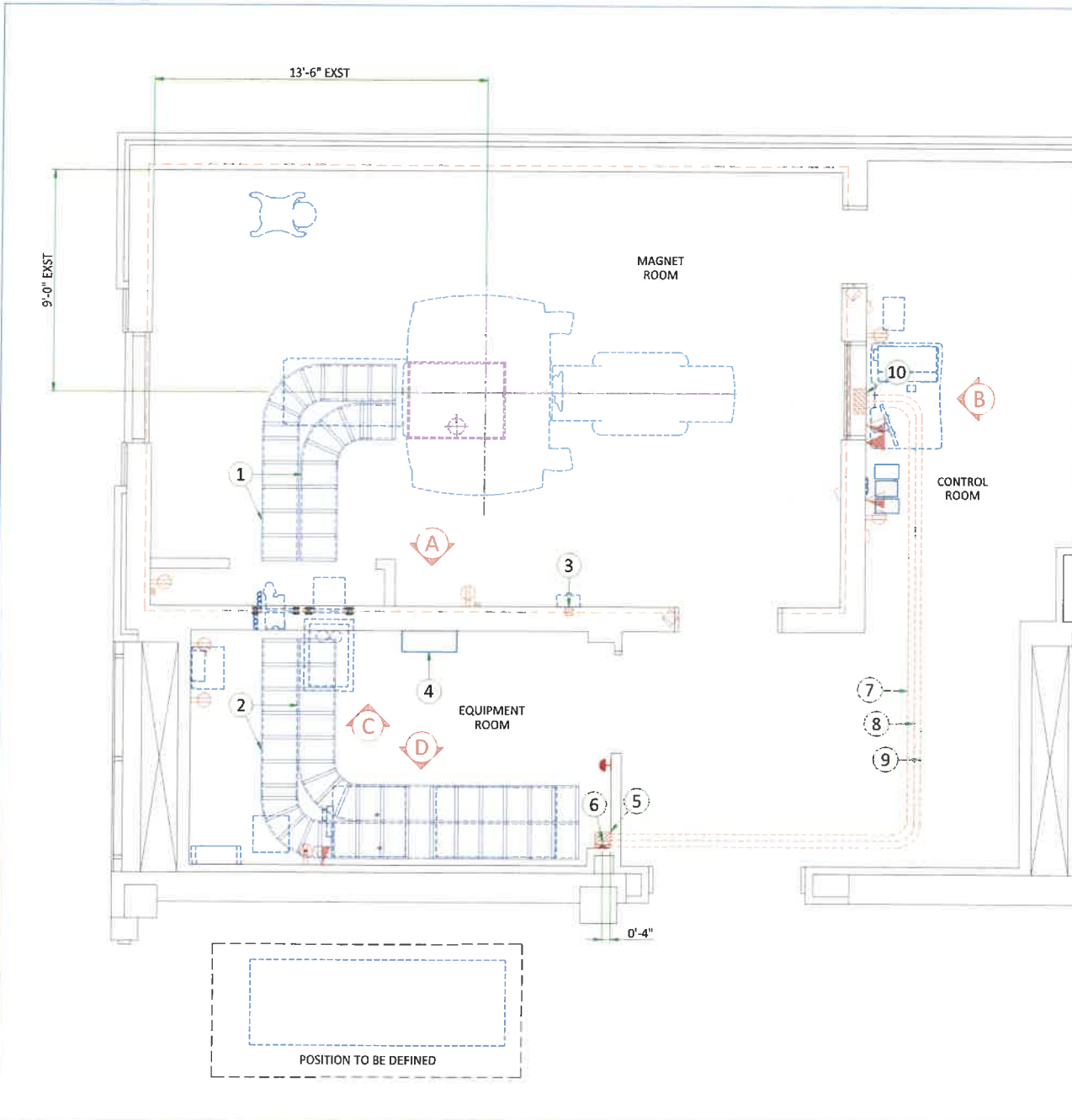

ITEM	DESCRIPTION (CONTRACTOR SUPPLIED & INSTALLED)
1	Non-ferrous cable ladder 18" x 6"
2	Cable ladder 18" x 6"
3	4" x 4" x 2" J-Box (Reuse existing location)
4	Main disconnect panel (Reuse existing location)
5	Box in/below floor size per local code
6	6" x 3 1/2" Surface wall duct
7	2" conduit below floor (Reuse existing if possible)
8	3" conduit below floor (Reuse existing if possible)
9	2 1/2" conduit below floor (New for injector)
10	12" x 8" x 6" J-Box (Reuse existing location)

ITEM	Outlet Legend for GE Equipment
	System emergency off (SEO), (recommended height 1.2m [48"] above floor)
	Door interlock switch (needed only if required by state/local codes)
	Emergency exhaust fan switch 1.2m [48"] height recommended)
	Duplex hospital grade, dedicated wall outlet 120-v, single phase power
	Network outlet
	Dedicated telephone lines/network connection
	Duplex hospital grade, dedicated outlet 120-v emergency, single phase power, 15a
	Duplex hospital grade, dedicated outlet 120-v, single phase outlet routed through RF filter

Additional Conduit Runs (Contractor Supplied and Installed)				
From	To	Qty	Size (in)	Size (mm)
Main Disconnect Panel	Facility power	1		as Req'd
	Power, Gradient, RF cabinet	1		as Req'd
	Heat Exchange Cabinet	1		as Req'd
System emergency off	Secondary Penetration Wall	1	1/2	16
	Door Switch	1	3/4	20
System emergency off	Secondary Penetration Wall	1	3/4	20
	Magnet	1	1	25
Magnet Rundown Unit	RF filter	1		as Req'd
RF filter	120-V 1Ø Power	1		as Req'd
Room Light	RF filter	1		as Req'd
RF filter	Facility emergency power	1		as Req'd
Chiller	Remote graphic display	1	3/4	20
	Facility power	1		as Req'd
Door Switch (1)	Door Switch	1	1	25
Injector control unit		1	2 1/2	70
Injector head	Waveguide or RF filter	1		as Req'd
Integrated Battery Charging Unit		1		as Req'd

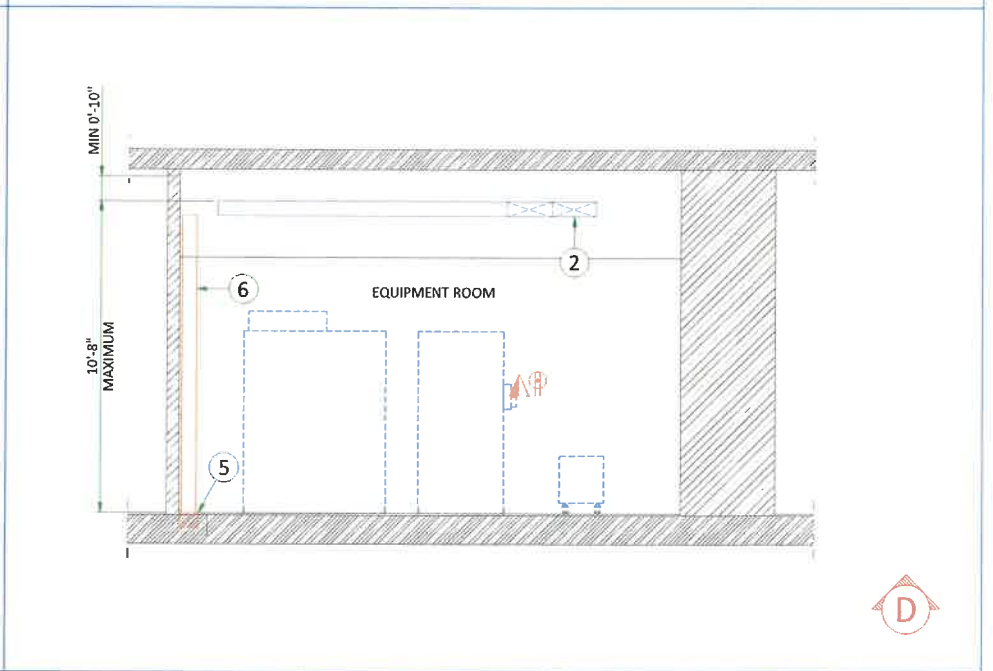
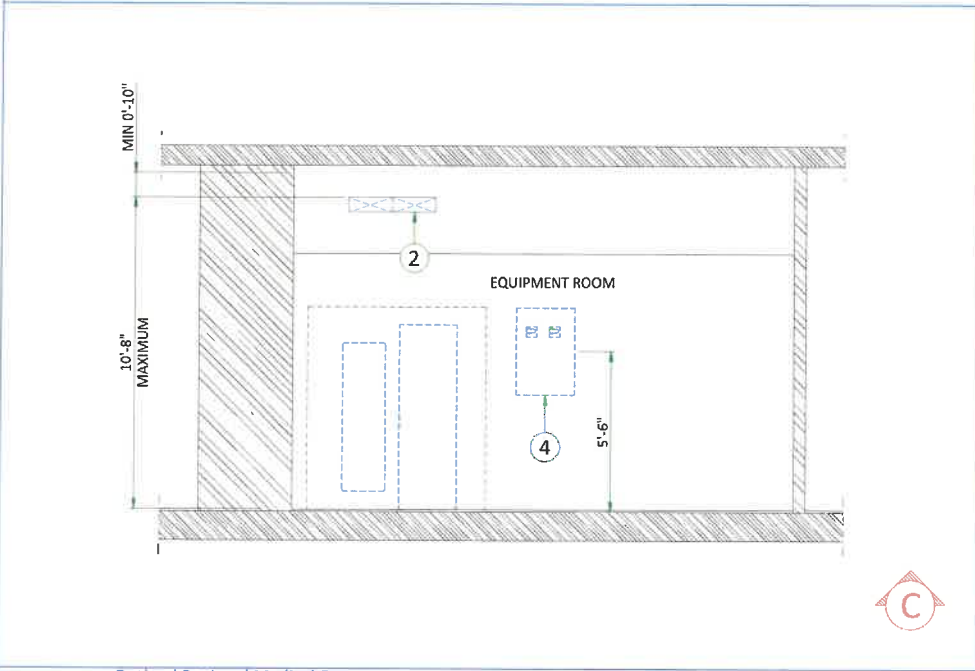
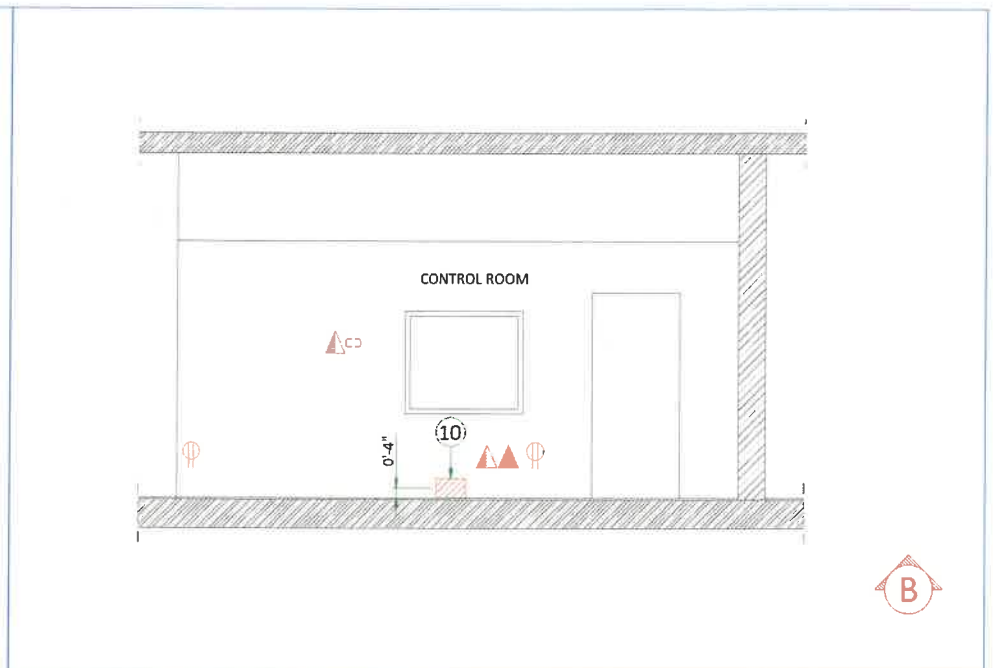
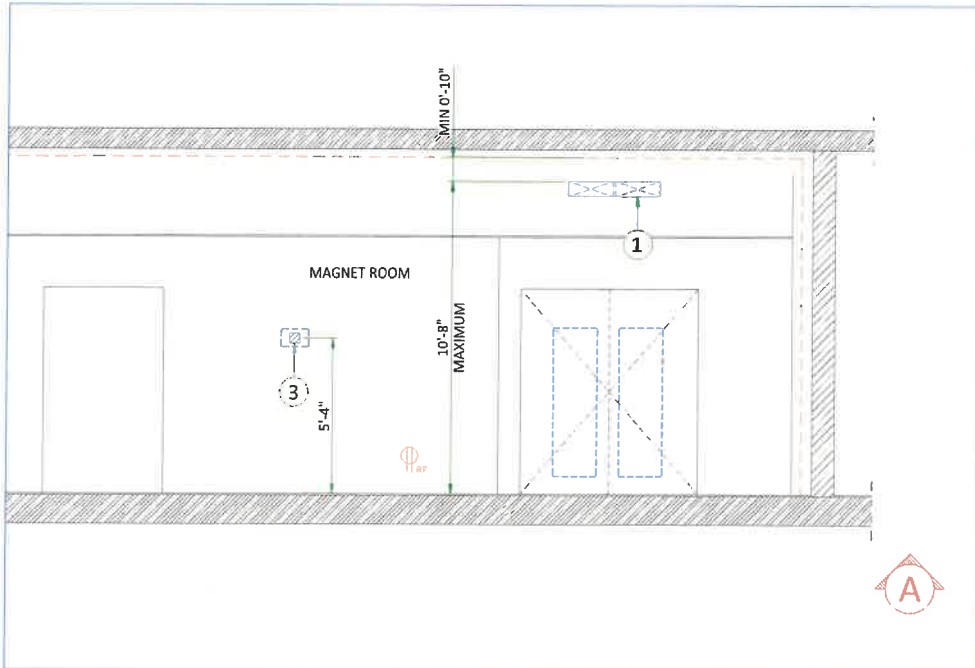

CABLE WAYS IN EQUIPMENT ROOM

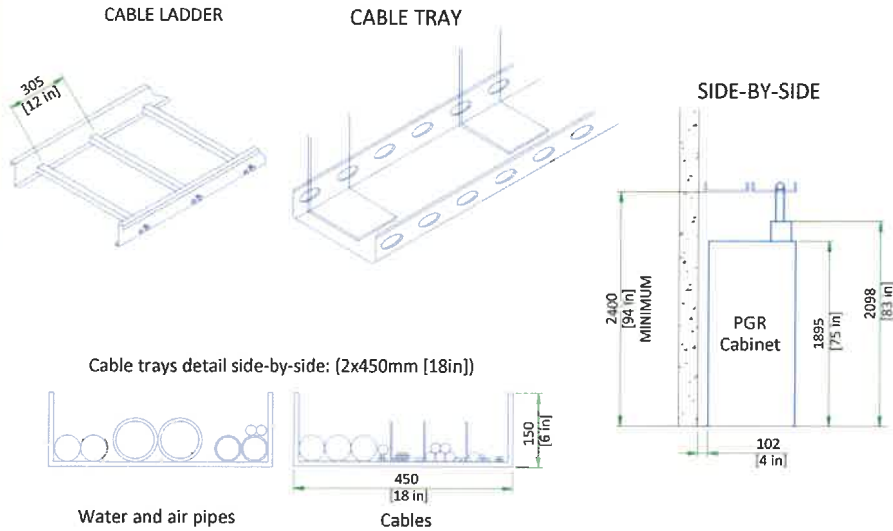

CABLE WAYS REQUIREMENTS IN MAGNET ROOM

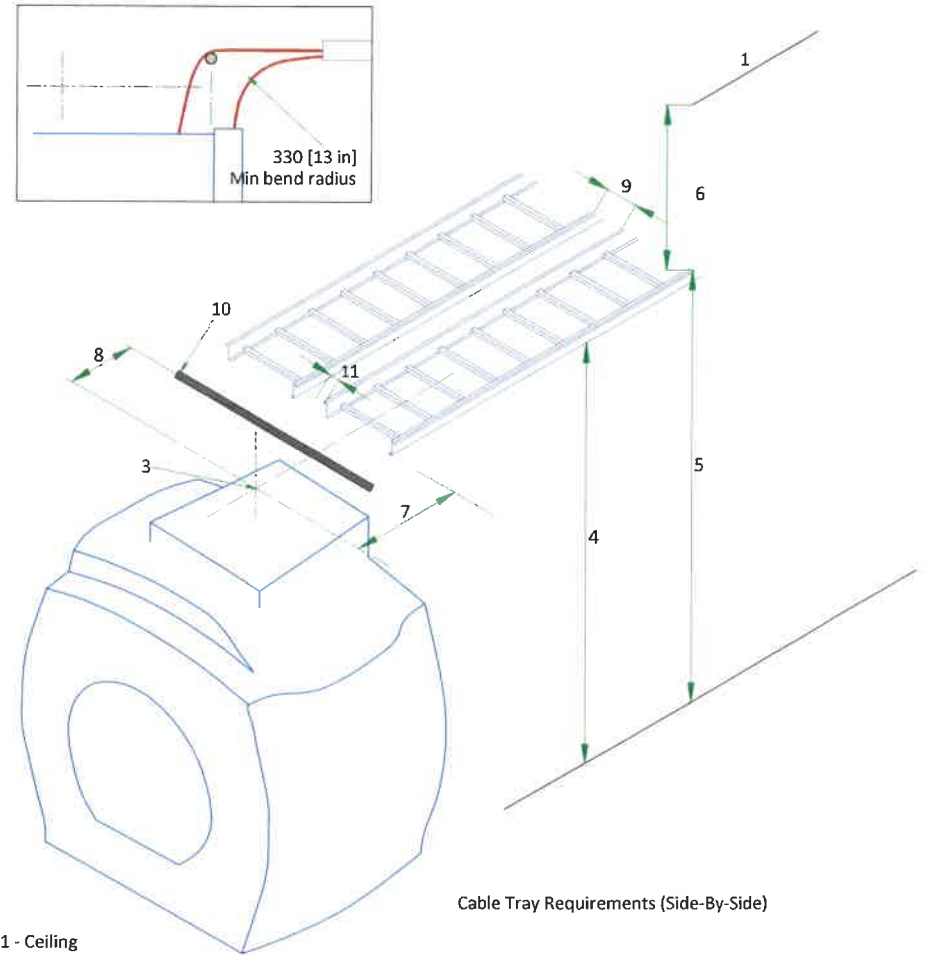

- 1 - Ceiling
- 2 - Finished Floor
- 3 - Magnet isocenter. Gradient cables must be centered on magnet isocenter.
- 4 - Minimum cable tray height required at back of Magnet: 2581 mm [101.5 in]. Tray height may be lower at other points to avoid obstructions.
- 5 - Maximum height from floor to top of tray (anywhere in Magnet room): 3251 mm [128 in].
- 6 - Minimum distance from top of cable tray to ceiling or other obstruction: 254 mm [10 in].
- 7 - Tray end to isocenter: 1099 ±12 mm [43.25 ±0.5 in].
- 8 - Other cable termination to isocenter: 718 ±12 mm [28.25 ±0.5 in].
- 9 - Minimum distance between trays: 12 mm [0.5 in].
- 10 - Non-ferrous cable support
- 11 - Distance from isocenter to edge of right cable tray 60mm [2.36 in].

CABLE WAY TO PENETRATION PANEL

CABLE WAY TO PENETRATION PANEL REQUIREMENTS IN THE EXAM ROOM SIDE VIEW

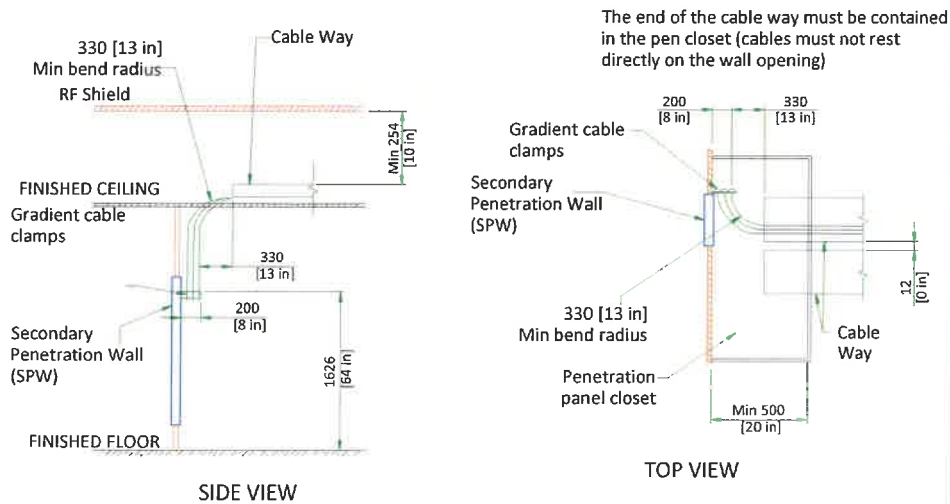

POWER REQUIREMENTS

SPECIFICATIONS OF MAIN POWER INPUT

POWER SUPPLY	380/400/415/480V ±10%, THREE-PHASE + N + G
FREQUENCIES	50/60Hz ± 3Hz
POWER FACTOR	0.9
MAXIMUM INPUT POWER (5 sec MAX)	123kVA
INSTALLED LOAD	99kVA
STAND-BY POWER	< 17kVA

- Power input must be separated from any others which may generate transients (elevators, air conditioning, radiology rooms equipped with high speed film changers...).
- Total harmonic distortion less than 2.5%.
- Phase imbalance must not exceed 2%.

SPECIFICATIONS OF BACK-UP POWER SUPPLY

FOR MAGNET MONITOR	
POWER INPUT	EMERGENCY POWER SUPPLY, SINGLE PHASE + GROUND
POWER DEMAND	2kVA
VOLTAGE	110V / 220V
FREQUENCY	50/60Hz ± 3Hz

FOR CRYOCOOLER COMPRESSOR	
POWER INPUT	380/400/415/480V, THREE-PHASE + G
POWER REQUIREMENT	MIN 9kVA
POWER CONSUMPTION	MAX 7.2kW / STEADY STATE 6.5kW at 50Hz MAX 8.3kW / STEADY STATE 7.5kW at 60Hz
FREQUENCY	50/60Hz ± 3Hz

CABLES

- Power and cable installation must comply with the distribution diagram.
- Size of the Main power input cable is determined by the customer, taking its length and admissible voltage drops into consideration.
- All cables must be isolated and flexible, cable color codes must comply with standards for electrical installation.
- The cables from signaling and remote control (Emergency Off Buttons, L...) will go to Main Panel with a pigtail length of 1.5m [60in], and will be connected during installation.
- Each conductor will be identified and isolated (screw connector).

GROUND SYSTEM

- The equipotential link will be by means of an equipotential bar.
- The grounding point of MDP is directly connected to the building's ground by an isolated copper cable.
- The impedance of the earth bar should be less than or equal to 2 ohms.

FEEDER TABLE

MIN. FEEDER WIRE SIZE, AWG OR MCM (sq. M)/VAC	MINIMUM FEEDER WIRE LENGTH - ft (m)							
	100 (30.5)	150 (46)	200 (61)	250 (76)	300 (92)	350 (107)	400 (122)	450 (137)
480 VAC	3/0 (85)	3/0 (85)	3/0 (85)	3/0 (85)	3/0 (85)	3/0 (85)	3/0 (85)	3/0 (85)
GROUND REQ'D	4	4	4	4	4	4	2	2

GENERAL NOTES

- In all cases qualified personnel must verify that the feeder (at the point of take-off) and the run to the MR system meet all the requirements stated in the PIM
- For a single unit installation, the minimum transformer size is 225KVA. Regulated transformer is not required unless voltage changes exceed +/- 10% over a period of 1 hour or longer
- Grounding conductor will run from the equipment back to the power source/main grounding point and always travel in the same conduit with the feeders

POWER DISTRIBUTION

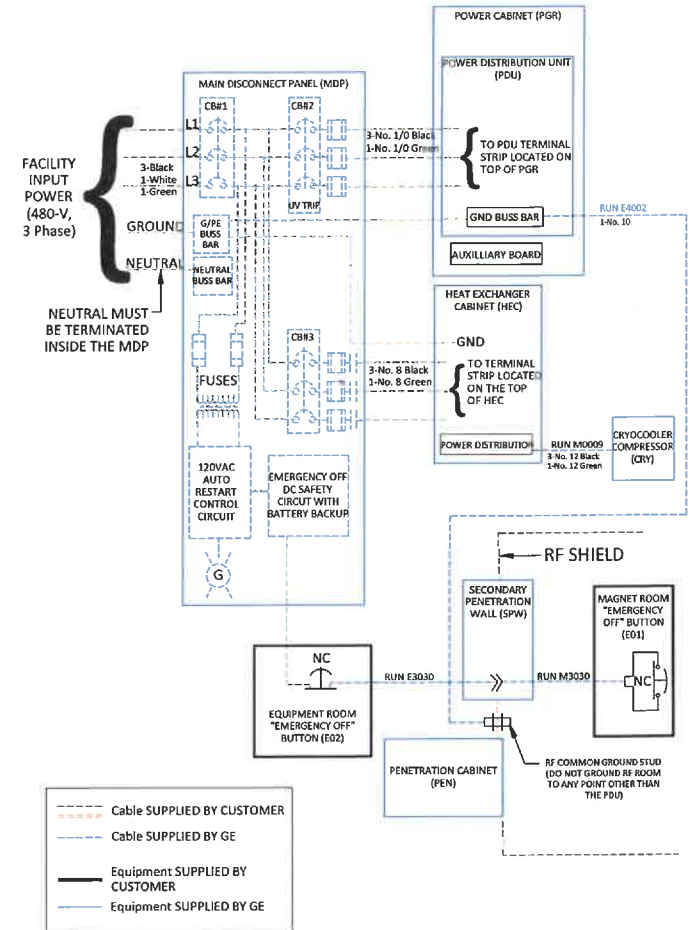

NOTE:

- THE HEAT EXCHANGER CABINET (HEC) PROVIDES POWER TO THE CRYOCOOLER COMPRESSOR (CRY) WHICH MUST OPERATE 24 HOURS PER DAY, 7 DAYS PER WEEK TO MAXIMIZE PROPER UNINTERRUPTED MAGNET OPERATION.
- RUNS E3030, M0009, M3030 AND E4002 ARE GE SUPPLIED CABLES. ALL OTHER WIRING IS CUSTOMER SUPPLIED.
- TWO REMOTE FLUSH WALL MOUNTED EMERGENCY OFF BUTTONS ARE SUPPLIED WITH THE MDP.
- MDP PROVIDES CIRCUIT BREAKERS FOR PDU (LOCATED IN THE POWER CABINET (PGR)) AND THE HEAT EXCHANGER CABINET (HEC).
- ALL MDP OUTPUT CIRCUITS DROP OUT ON LOSS OF POWER. THE HEC CIRCUIT WILL AUTOMATICALLY RESTART UPON RESTORATION OF POWER. EMERGENCY OFF LOCKS OUT ALL CONTRACTORS.
- GE MDP SHORT CIRCUIT CURRENT RATING IS 25,000 AMPERES AT 480 VAC.
- GE MDP IS UL AND cUL LABELED.
- ALL CIRCUITS REQUIRE GROUND WIRES.
- THE WIRE SIZE FOR THE EMERGENCY-OFF CIRCUIT IS 12-22 AWG CUSTOMER SUPPLIED

INTERCONNECTIONS

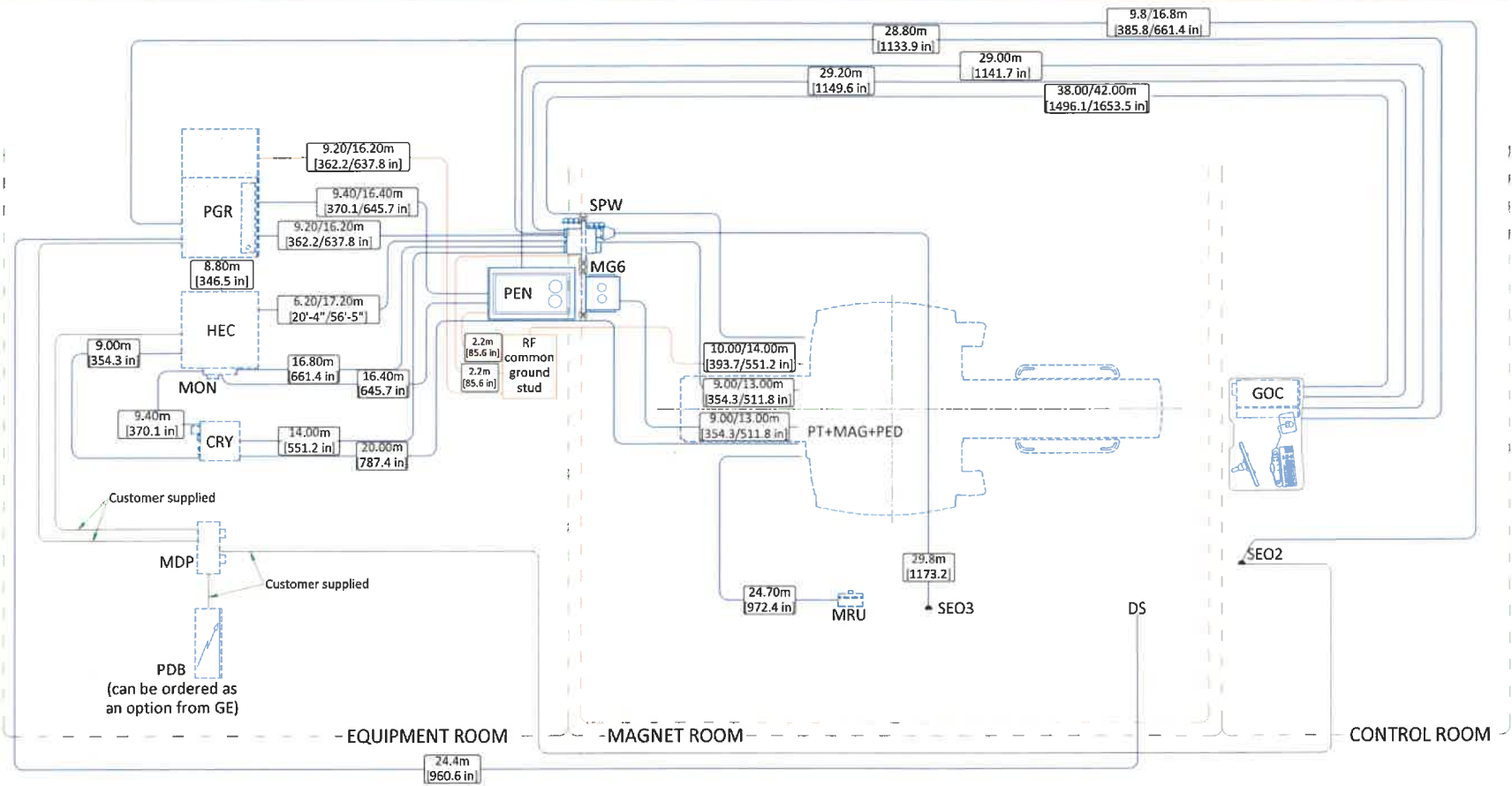

CABLES ROUTING		
Configuration	Equipment Room	Magnet Room
A	Short	Short
B	Long	Short
C	Short	Long

CABLES ROUTING FOR OPTIONS				
OPTION	FROM	TO	CABLE LENGTH	
BW	PEN	Brainwave cabinet	18.28 m	720 in
MRE	MRE	Magnet Isocenter	Nominal: 7.31m Maximum: 10.06m	Nominal: 288 in Maximum: 396 in
	MRE	PEN cabinet	15.24m	600 in
	MRE	Ethernet Hub in PGR	15.24m	600 in
	MRE	Customer Supplied Outlet	60Hz: 6.10m 50Hz: 7.62m	60Hz: 240 in 50Hz: 300 in

Service Report Downtime Summary for GE 1.5T HDXT MRI Scanner at RRMC SID 802747MR

For the last 12 months the Total downtime was 126 hours

Avg downtime per month was 10.5 hours

At the bottom of this report is the Equipment service History.

Each event for this system generated an SR. Attached to each SR is an activity for each Engineer who supported the repair. Some repairs were done while the MRI system was scanning either onsite or remotely so no system down time was incurred.

The system downtimes compiled were the hours that the MRI was not available to scan due to maintenance and or repair.

Service Reports for SID 802747MR

CR

25 Jun 2021 System Downtime for this event: 1.0

Status: Open Owner: Harold Flad

Problem:

8Ch NeuroVascular coil "Invivo" GE Part # 2317115-2
 Assembly # 103045 shows low signal on one or more
 channels. Passes MCQA

CR

21 Jun 2021 System Downtime for this event: 2.0

Status: Closed Owner: Charles Nutt

Problem:

We iLinqed today about pre scan failure, they said it might
 be the A port, just tried Abdomen scan and got the same pre
 scan failure. Brain coil is working fine, it seems anything
 with A port gets the pre scan failure. Image:NONE-NONE-
 NONE

CR

21 Jun 2021 System Downtime for this event: 3.0

Status: Closed Owner: Harold Flad

Problem:

Driver Module fault Image:NONE-NONE-NONE

CR 18 Jun 2021	System Downtime for this event: 69.0	Status: Pending Approval	Owner: Robert Ochal	Problem: Getting error, PDCU is in stop mode, Emergency stop button was pressed or PDU 24 volt supply has failed. We did not hit the emergency stop. Image:NONE-NONE-NONE
PM 17 Jun 2021	System Downtime for this event: 0.0	Status: Open	Owner: Harold Flad	Problem: PM Jul 2021
CR 15 Jun 2021	System Downtime for this event: 0.0	Status: Open	Owner: Harold Flad	Problem: Analogic RF Amplifier Peak Power Fault in error log CD 06/16/2021 08:00:00 (GMT-05:00) Eastern Time (US & Canada) Customer has delayed service, please refer to the Planned Date to get this information and page the FE when needed. / Customer Symptom: Axial t2 and PD sequences on Lumbar scans giving RF failure error. Tried TPS reset, did not fix issue. Weekend techs said the same error happened on lumbar scan this last weekend. Unable to run both axial t2 and PD, all sag sequences ran without issue. Image:Lumbar wo-1446,1447-NONE <S>
CR 14 Jun 2021	System Downtime for this event: 0.0	Status: Closed	Owner: David Baxter	Problem: NVA image quality complaint
CR 14 Jun 2021	System Downtime for this event: 0.0	Status: Closed	Owner: Harold Flad	Problem: low signal on one channel on Invivo 8 Ch brain coil
CR 07 Jun 2021	System Downtime for this event: 1.0	Status: Closed	Owner: Harold Flad	Problem: Knee coil will not pass MCQA
CR 03 Jun 2021	System Downtime for this event: 0.0	Status: Closed	Owner: David Baxter	Problem: ongoing white pixels
CR 02 Jun 2021	System Downtime for this event: 6.5			

Status:	Closed	Owner:	Douglas Cyr	Problem:	EPIWP analysis for FE.
CR	System Downtime for this event: 1.0				
	18 May 2021				
Status:	Closed	Owner:	Alejandro Jasso	Problem:	Customer states that the unit is down.
CR	System Downtime for this event: 27.0				
	25 Apr 2021				
Status:	Pending Approval	Owner:	Douglas Cyr	Problem:	Customer states that the computed on the machine crashed and won't reboot.
CR	System Downtime for this event: 2.0				
	19 Mar 2021				
Status:	Assigned	Owner:	Harold Flad	Problem:	White Pixel noise causing Intermittent corduroy artifact on some coils
PM	System Downtime for this event: 0.0				
	16 Mar 2021				
Status:	Cancelled	Owner:	Harold Flad	Problem:	PM Apr 2021. Exempted - Revised PM DUE Date Jun 2021.
CR	System Downtime for this event: 0.0				
	02 Mar 2021				
Status:	Closed	Owner:	Alejandro Jasso	Problem:	Customer needs service reports.
CR	System Downtime for this event: 1.5				
	27 Feb 2021				
Status:	Closed	Owner:	Robert Ochal	Problem:	CD 3/1/2021 08:00 AM COULD YOU PLEASE NOTIFY OUR FE THAT WE ARE HAVING TROUBLE WITH THE NUMBER 3 COIL IN OUR 16CH NEURO ARRAY COIL. PLEASE HAVE HIM GIVE US A CALL ON MONDAY. THANKS Image:NONE-NONE-NONE
CR	System Downtime for this event: 1.5				
	26 Jan 2021				

Status: Closed Owner: Harold Flad Problem: artifact on DWI, cube and fiesta sequences. Noticed a few days ago, continuing today. Image:NONE-NONE-NONE

CR System Downtime for this event: 1.0
25 Dec 2020

Status: Closed Owner: Kyle Tempesta Problem: Breaker to PDU tripped. System reset but TPS system not responding after multiple resets. Image:NONE-NONE-NONE

CR System Downtime for this event: 0.0
22 Dec 2020

Status: Closed Owner: Gary Henning Problem: I SEE THAT SOMEONE IS IN MY SYSTEM. COULD THEY PLEASE LOOK TO SEE WHY IM GETTING MULTI BIAS-FAULT ERRORS. Image:NONE-NONE-NONE

PM System Downtime for this event: 3.0
16 Dec 2020

Status: Closed Owner: Harold Flad Problem: PM Jan 2021

CR System Downtime for this event: 0.0
13 Dec 2020

Status: Closed Owner: Avery Thomas Problem: Equipment room overheated. Maintenance working on AC. Chiller off most of the night. back on around 0930 this morning. Able to scan for short while but now getting Gradient problem messages. Please call 802-747-1707. Image:NONE-NONE-NONE

CR System Downtime for this event: 0.0
13 Dec 2020

Status: Closed Owner: Charles Nutt Problem: MRM80002. P1 - Compressor Off (Magnet)

CR System Downtime for this event: 0.0
07 Dec 2020

Status: Open Owner: Harold Flad

Problem:

Default Password Update – Insite One – During your next service or PM, please change the passwords identified in the Service Note for this modality. The new password will be the “Row-ID” identifier for this system ID and can be found in Service Request screen (Not the Activity Screen) under the heading System Info in FX. In your debrief “Action” comments, confirm “Password changed to “XXXXXXX” to document the actual password used. Consult your service documentation or contact Technical Support if you have questions. Reminder: passwords are case sensitive, and mistakes will likely require reset via LFC!

CR System Downtime for this event: 0.0
16 Nov 2020

Status: Closed Owner: William Nichol

Problem:

MRM80002. P1 - Compressor Off (Magnet)

CR System Downtime for this event: 0.5
08 Nov 2020

Status: Closed Owner: Gary Henning

Problem:

We are starting to see gradient amplifier not ready messages when trying to do Axial T2 FSE sequences. Has happened a couple of times this week. Most recently about 5 mins ago. Image:NONE-NONE-NONE

PM System Downtime for this event: 1.0
16 Sep 2020

Status: Closed Owner: Harold Flad

Problem:

PM Oct 2020

CR System Downtime for this event: 1.0
31 Aug 2020

Status: Closed Owner: Harold Flad

Problem:

12 channel anterior coil cabling has a crack in the cover.

CR System Downtime for this event: 1.0
25 Jun 2020

Status:	Closed	Owner:	Harold Flad	Problem:	There is a problem with the alignment on the table. It is rubbing as it comes out and causing a horrible grinding noise. Could you please let my FE know he needs to come and adjust it. Image:NONE-NONE-NONE
PM	System Downtime for this event: 3.0				
16 Jun 2020					
Status:	Closed	Owner:	Harold Flad	Problem:	PM Jul 2020

NOTE: When completing this table make entries in the shaded fields only.

Rutland Regional Medical Center
MRI CoN
 TABLE 1
 PROJECT COSTS

Construction Costs	
1. New Construction	-
2. Renovation	731,186
3. Site Work	2,800
4. Fixed Equipment	-
5. Design/Bidding Contingency	-
6. Construction Contingency	\$72,741
7. Construction Manager Fee	41,691
8. Other (please specify)	-
Subtotal	\$ 848,418
Related Project Costs	
1. Major Moveable Equipment	\$ 1,899,230
2. Furnishings, Fixtures & Other Equip.	\$84,842
3. Architectural/Engineering Fees	\$172,263
4. Land Acquisition	-
5. Purchase of Buildings	-
6. Administrative Expenses & Permits	-
7. Debt Financing Expenses (see below)	-
8. Debt Service Reserve Fund	-
9. Working Capital	-
10. Other - Owner Contingency	84,842
Subtotal	\$ 2,241,177
Total Project Capital Costs	\$ 3,089,595
Total Project Operating Costs	\$ 199,276

Debt Financing Expenses	
1. Capital Interest	\$ -
2. Bond Discount or Placement Fee	-
3. Misc. Financing Fees & Exp. (issuance costs)	-
4. Other	-
Subtotal	\$ -
Less Interest Earnings on Funds	
1. Debt Service Reserve Funds	\$ -
2. Capitalized Interest Account	-
3. Construction Fund	-
4. Other	-
Subtotal	\$ -
Total Debt Financing Expenses	\$ -
feeds to line 7 above	

NOTE: When completing this table make entries in the shaded fields only.

Rutland Regional Medical Center
MRI CoN
TABLE 2
DEBT FINANCING ARRANGEMENT, SOURCES & USES OF FUNDS

Sources of Funds			
1. Financing Instrument	Bond		
a. Interest Rate	0.0%		
b. Loan Period		To:	
c. Amount Financed			\$ -
2. Equity Contribution			3,089,595
3. Other Sources			
a. Working Capital			-
b. Fundraising			-
c. Grants			-
d. Other			-
Total Required Funds - Capital			\$ 3,089,595
Total Required Funds - Operating (Funded by Equity)			\$ 199,276

Uses of Funds			
<u>Project Costs (feeds from Table 1)</u>			
1. New Construction			\$ -
2. Renovation			731,186
3. Site Work			2,800
4. Fixed Equipment			-
5. Design/Bidding Contingency			-
6. Construction Contingency			72,741
7. Construction Manager Fee			41,691
8. Major Moveable Equipment			1,899,230
9. Furnishings, Fixtures & Other Equip.			84,842
10. Architectural/Engineering Fees			172,263
11. Land Acquisition			-
12. Purchase of Buildings			-
13. Administrative Expenses & Permits			-
14. Debt Financing Expenses			-
15. Debt Service Reserve Fund			-
16. Working Capital			-
17. Other (please specify)			84,842
Total Uses of Funds - Capital			\$ 3,089,595
Total Uses of Funds - Operating			\$ 199,276

Total sources should equal total uses of funds.